

Z11
Integrated supply module

- 1) DME main relay
- 2) Relay for ignition and fuel injection
- 3) Valvetronic relay
- 8) Relay power supply sensors/actuators

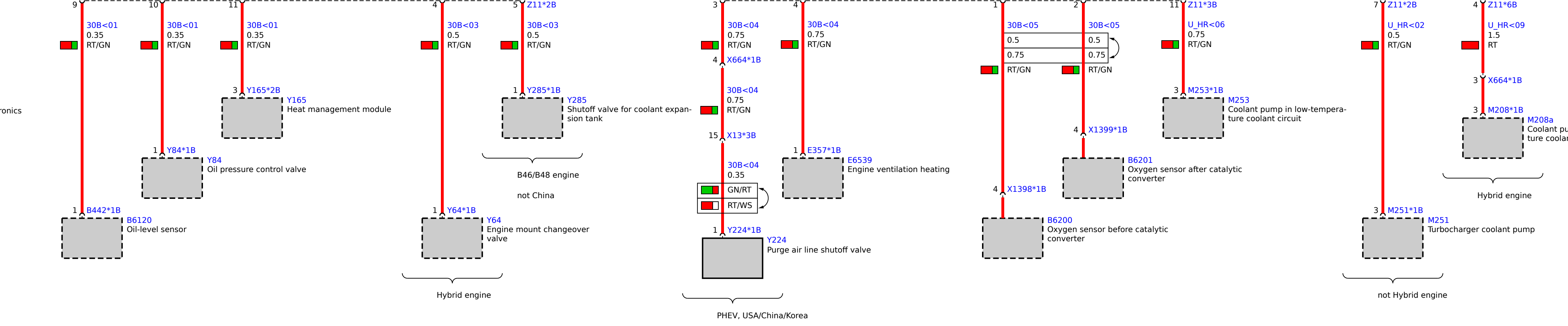
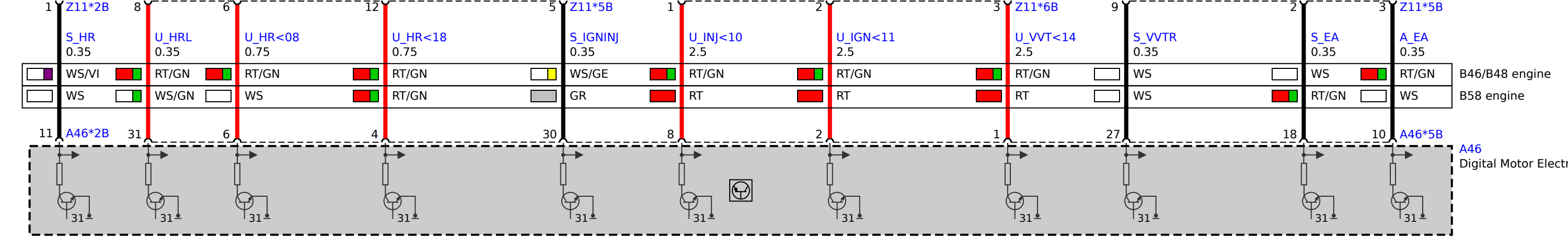

Hybrid engine

not Hybrid engine