

## 11 00 050 Removing and installing engine



**Hot fluids.**

**Risk of scalding!**

- Conduct all work in the vehicle wearing appropriate personal protective equipment only.



**Motor vehicle may slip off the vehicle hoist if the weight is distributed unevenly.**

**Danger! Life-threatening injuries!**

- Ensure there is a specific weight compensation on the motor vehicle.



**Motor vehicle may slip off the vehicle hoist where components are supported.**

**Danger! Life-threatening injuries!**

- Secure the vehicle hoist against lowering and lifting.



**Vehicle may slip off the vehicle hoist if the vehicle hoist is handled incorrectly.**

**Danger! Life-threatening injuries!**

- Observe safety information on raising the vehicle using a vehicle hoist.
- For additional information see: 00 ... Raise the vehicle using a vehicle lift.



**Materials harmful to health.**

**Contact with fluids harmful to health!**

- Note and follow safety information on containers.
- Conduct all work in appropriate personal protective equipment only.



**Electrostatic discharge.**

**Damage to or destruction of electrical components.**

- Leave electrical components in original packaging until just before they are installed. Use the original packaging only for any return shipments. Always package removed components straight away.
- Read and comply with user information on using the associated special tool 12 7 060.
- Only touch the housings of electrical components. Do not touch pins or multi-pin connectors directly.
- Wear electrically conductive clothing and antistatic shoes (with ESD symbol).
- For additional information see: 61 35 ... Notes for ESD protection (electrostatic discharge)



Follow notes for repair work on the cooling system.

For additional information see:

Main group 17

17 00 ... Notes for working on the cooling system



### Life-long fill of coolant!

Do not reuse used coolant.

When replacing and removing components which rely on the corrosion protection effect of the coolant, it is essential to change the coolant. The cooling system must therefore be emptied and refilled.

In the case of other removal work involving the draining of part quantities of coolant, the coolant level must be topped up with new coolant.



Filling **without** the vacuum filler device (watering can filling) is **not permitted**.

Non-compliance will result in danger of component and/or engine damage.

Filling specification **absolutely must** be adhered to.

Operation of the vehicle is not permitted unless the filling procedure has been completed. Otherwise, functional limitations (degradation) and/or overheating may occur.

A bleeding procedure is required after a part has been exchanged in the cooling system and/or after refilling the cooling system.



Collect and dispose of emerging fluids. Observe country-specific waste disposal regulations.



Disconnecting control units may cause fault code entries and functional limitations. Fault code entries must be read out and deleted if necessary.

## PRELIMINARY WORK

### 1 – Drawing off the air conditioning

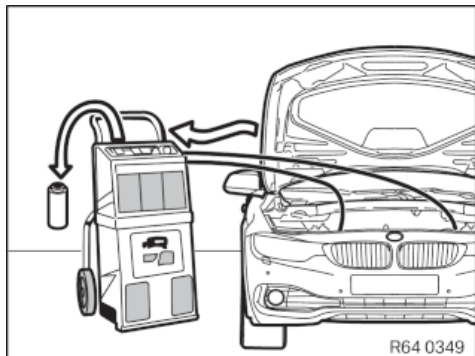

- See additional information.

### 2 – Removing the acoustic cover



**Hot surfaces.**

**Risk of burning!**

- Perform all work only on components that have cooled down.



**Damage to the acoustic cover/design cover.**

**Jerky movements during disassembly and excessive application of force during installation may result in breakage of the acoustic cover/design cover.**

- Disassemble or mount the acoustic cover/design cover carefully.
- Disassemble or mount snap-lock couplings of the ball pivots one after the other.
- Disassemble or mount acoustic cover/design cover only at temperatures >20 °C.
- Use only distilled water as an auxiliary material during installation, no lubricants.

- Unclip the acoustic cover from the marked areas towards the top.

**3 – Remove the intake neck for intake silencer housing**

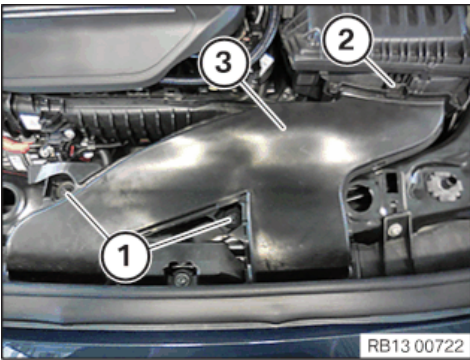

- Loosen nuts (1).
- Loosen the lock (2).
- Guide the intake neck (3) out and remove it.

**4 – Removing intake silencer housing**

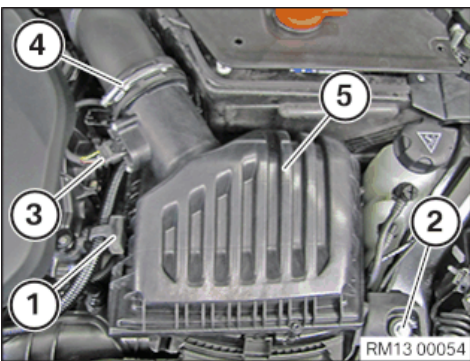

- Loosen the holder (1).
- Loosen screw (2).
- Unlock and release plug connection (3).
- Unfasten clamp (4).
- Pull out and remove the intake silencer housing (5) from the rubber mounts towards the top.

**5 – Removing the cover on top**

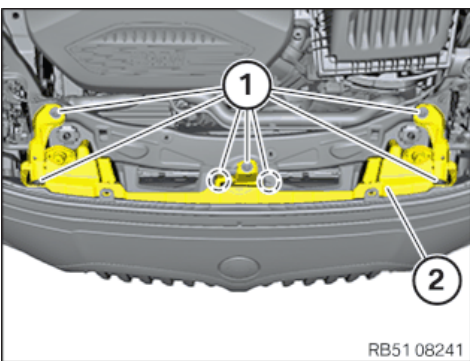

- Loosen screws (1).
- Pull the cover (2) out upwards and remove it.

**6 – Partially releasing reinforcement strut**

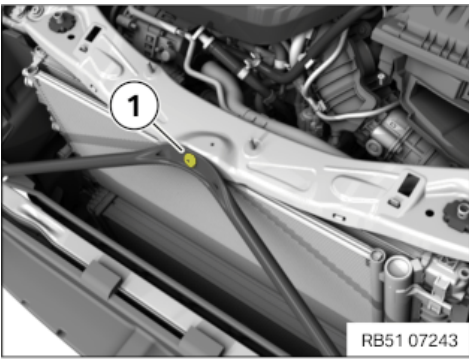

- Release screw (1) of reinforcement strut.

## 7 – Remove cross connection

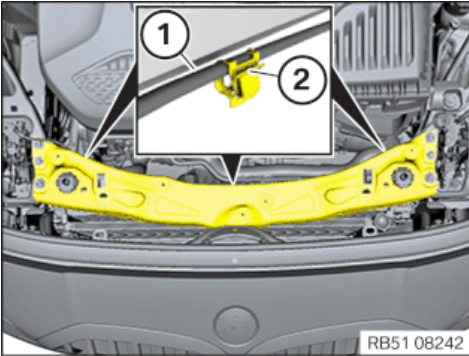

- Release the Bowden cable (1) from the cross connection using the clamps (2).

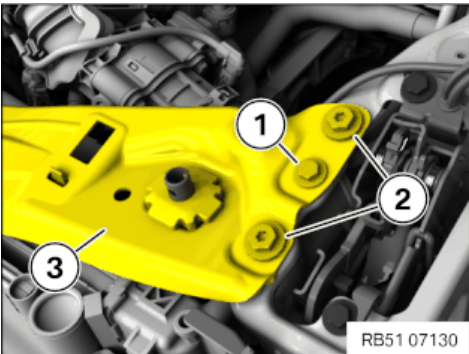

The operations shown only for one side must be carried out on both sides.

- Loosen screw (1).
- Loosen screws (2).
- Feed out and remove the cross connection (3) upwards.

## 8 – Removing the fan cowl with electric fan



**Hot surfaces.**

**Risk of burning!**

- Perform all work only on components that have cooled down.

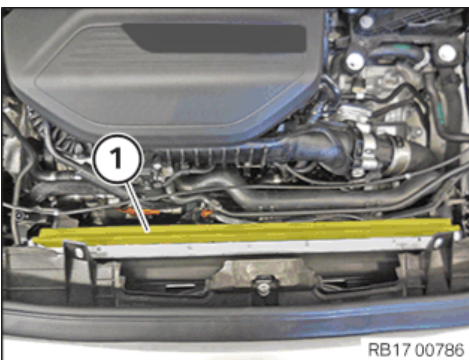

- Feed out and remove the sealing (1) from the radiator.

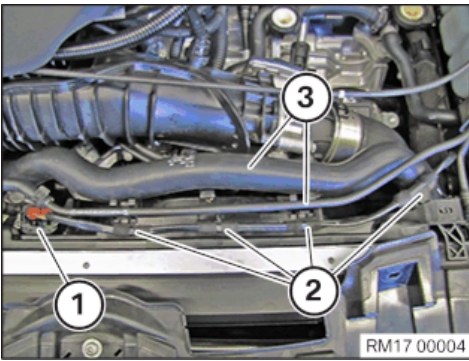

- Unlock plug connection (1) and disconnect.
- Unlock and loosen the clamps (2).
- Feed out connector (1) and place to one side.
- Feed out coolant lines (3) and lay to one side.

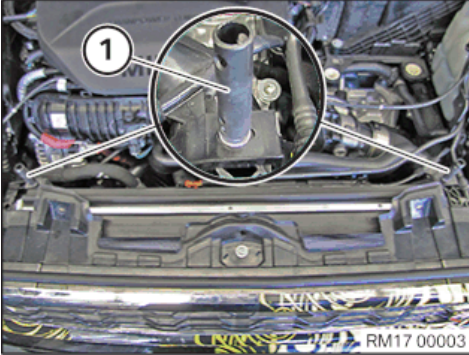

- Loosen screws (1).

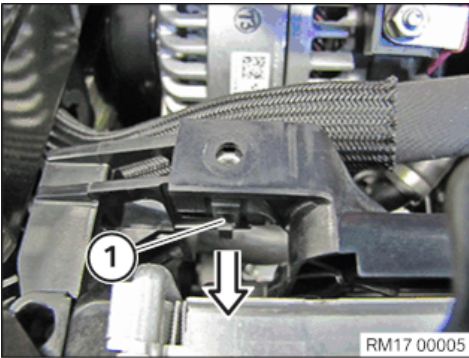

- Unlock the right lock (1) on the fan cowl in the direction of the arrow.

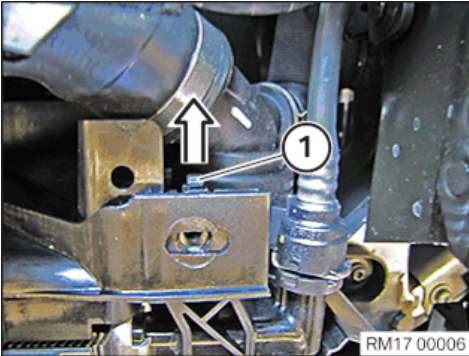

- Unlock the left lock (1) on the fan cowl in the direction of the arrow.

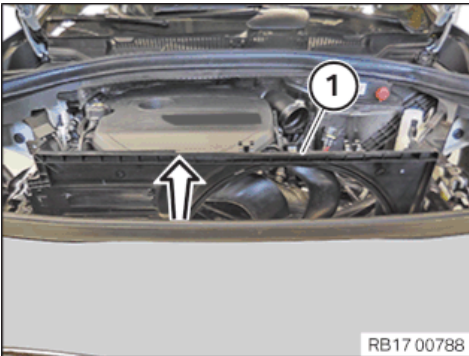

- Feed out fan cowl (1) with electric fan in direction of arrow and remove.

## 9 – If installed: Remove rear underbody protection

- ▶ Remove rear underbody protection

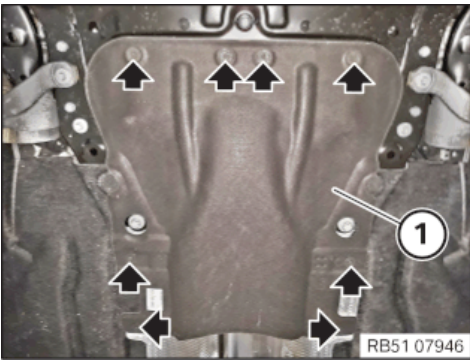

- Remove screws (arrows).
- Guide out rear underbody protection (1) and remove it.

## 10 – Removing the front underbody protection



Different variants may be installed depending on the vehicle equipment.

### ► Remove front right cross-member



Description is for left component only. Procedure on the right side is identical.

### ▷ Removing the front cross-member



The following work step(s) is / are to be carried out if the specified component(s) is/are fitted.

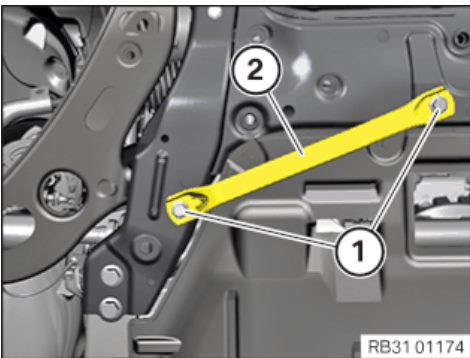

- Loosen screws (1).
- Remove the front cross-member (2).



### • Version A:

Remove screws (arrows).

Feed out the front underbody protection (1) at the bumper panel (2) and remove.

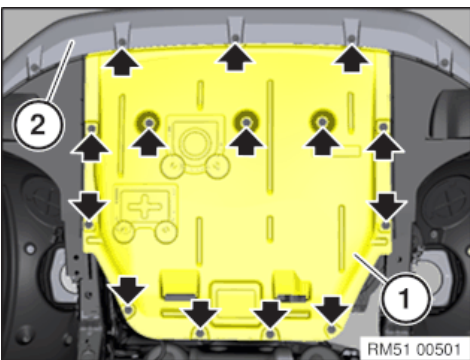

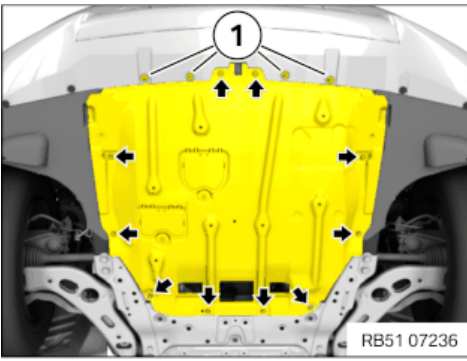

• **Version B (S8SDA):**

Loosen screws (1).

Remove screws (arrows).

Feed out the front underbody protection on the bumper panel and remove.

**11 – Removing right underbody panelling**

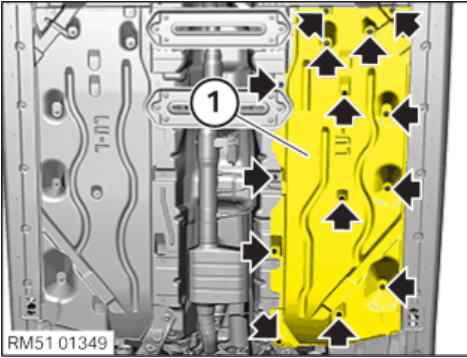

• Unscrew all bolts and nuts (arrows).

• Remove the underbody panelling (1).

**12 – Releasing the oil drain plug**



**Hot fluids.**

**Risk of scalding!**

- Conduct all work in the vehicle wearing appropriate personal protective equipment only.

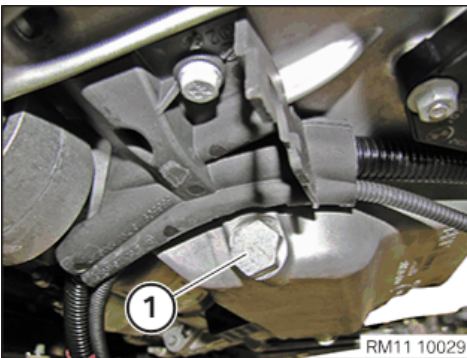

Catch and dispose of drained engine oil in a suitable collecting vessel. Observe country-specific waste disposal regulations.

• Release oil drain plug (1).

• Drain engine oil.

**13 – Tightening the oil drain plug**

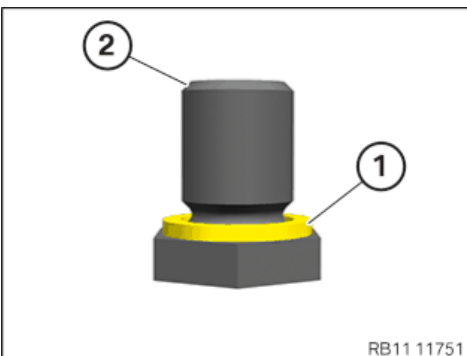

• Renew sealing ring (1) on the oil drain plug (2).

**Parts:** Sealing ring

• Guide in the sealing ring (1) on the oil drain plug (2) and install.

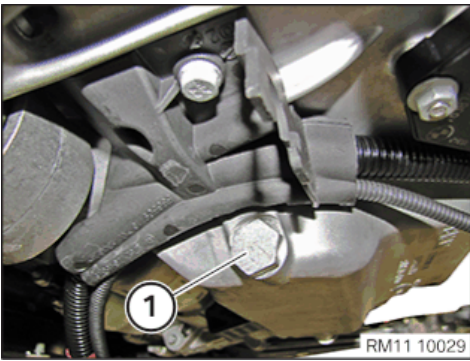

- Renew the sealing ring.
- Position oil drain plug (1) on the oil sump and tighten.

#### Oil drain plug on oil sump

Part	Operation	Tightening torque
M12x1.5	Renew the sealing ring.	25 Nm

## 14 – Draining coolant



**Hot fluids.**

**Risk of scalding!**

- Conduct all work in the vehicle wearing appropriate personal protective equipment only.



**Life-long fill of coolant!**

Do not reuse used coolant.

When replacing and removing components which rely on the corrosion protection effect of the coolant, it is essential to change the coolant. The cooling system must therefore be emptied and refilled.

In the case of other removal work involving the draining of part quantities of coolant, the coolant level must be topped up with new coolant.



Collect and dispose of emerging fluids. Observe country-specific waste disposal regulations.

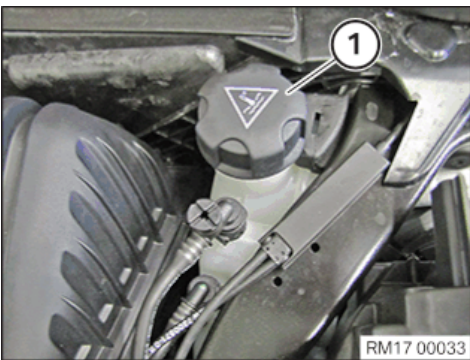

- Loosen sealing cap (1).

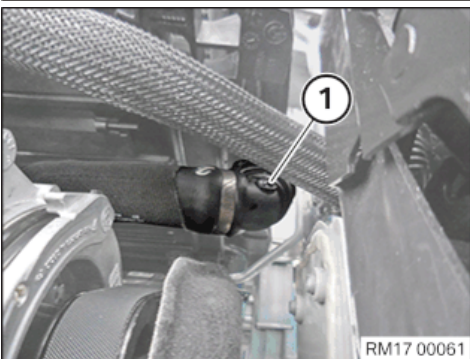

- Unlock and disconnect the coolant line (1) from the radiator on the right.
- Catch and dispose of escaping coolant.

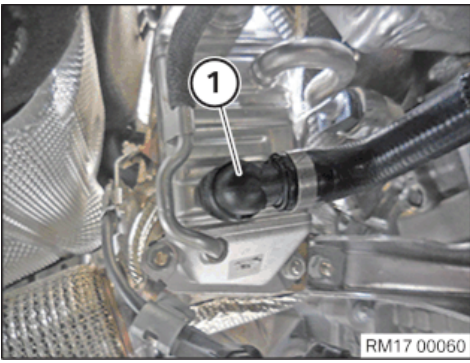

- Unlock and pull off the coolant line (1) from the low pressure exhaust-gas recirculation cooler on the diesel particulate filter.
- Catch and dispose of escaping coolant.

### 15 – Install cross connection

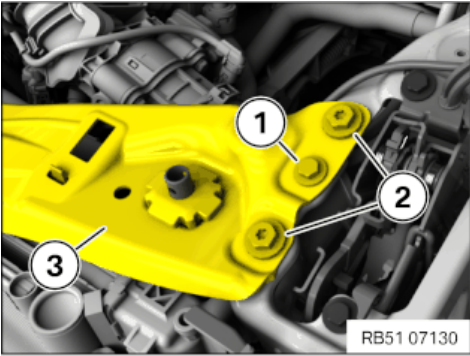

The operations shown only for one side must be carried out on both sides.

- Insert the cross connection (3) and position correctly.
- Tighten the screws (2).

#### Cross connection on bonnet catch support

Hexagon screw	Tightening torque	28 Nm
---------------	-------------------	-------

- Tighten down screw (1).

#### Bonnet lock to bonnet lock support

Hexagon screw M6x16	Tightening torque	11,8 Nm
------------------------	-------------------	---------

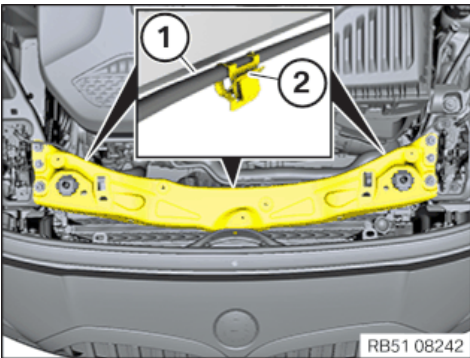

- Secure bowden cable (1) with the clamps (2) to the top connection.

### 16 – If installed: Remove suspension cross-brace

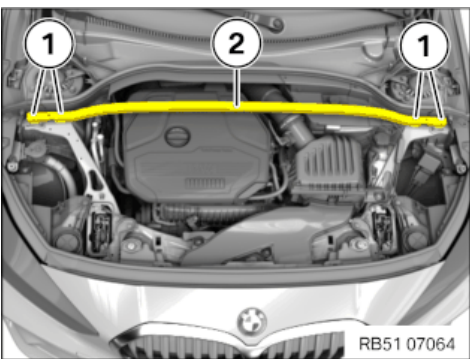

- Loosen screws (1).
- Remove the strut brace (2).

### 17 – Remove the seal for the rear bonnet



Schematic diagram is for example purposes. Some parts may differ in certain details.

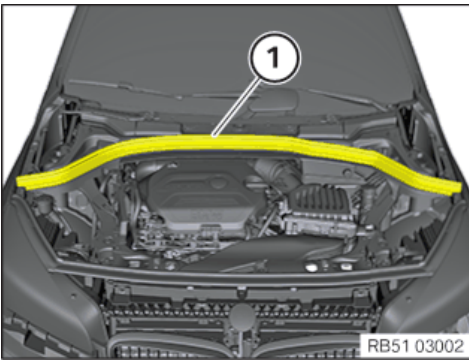

- Pull off the bonnet seal (1) towards the top and remove.

## 18 – Removing front cowl panel cover

### ► Detach cables (for equipment specification with electronic Damper Control)

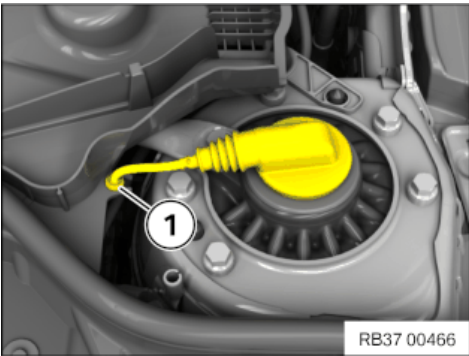

- Unclip the cable (1) from the front cowl panel cover.

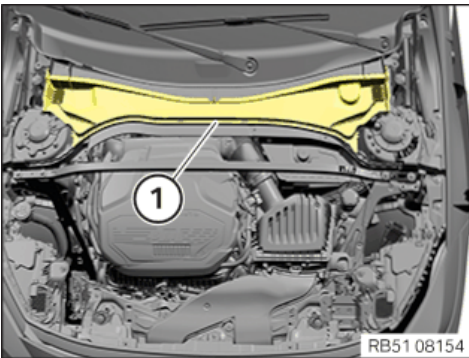

Schematic diagram is for example purposes. Some parts may differ in certain details.

- Pull the front cowl panel cover (1) forward out of the rear cowl panel cover and remove.

## 19 – Removing the upper bulkhead cover

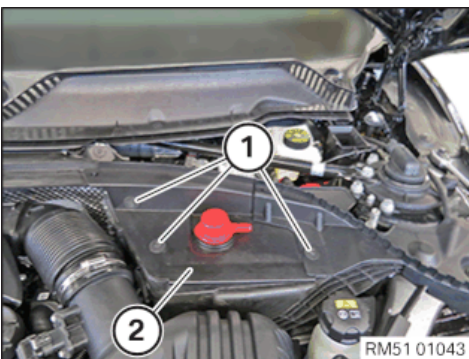

- Loosen screws (1).
- Guide out and remove the cover (2).

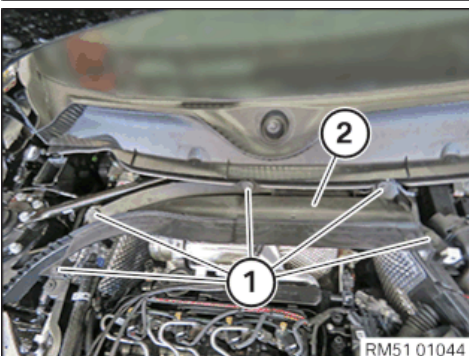

- Loosen screws (1).
- Feed out and remove the upper bulkhead cover (2).

## 20 – Remove electronics box

### Prerequisite

Battery earth lead is disconnected.



### Electrostatic discharge.

#### Damage to or destruction of electrical components.

- Leave electrical components in original packaging until just before they are installed. Use the original packaging only for any return shipments. Always package removed components straight away.
- Read and comply with user information on using the associated special tool 12 7 060.
- Only touch the housings of electrical components. Do not touch pins or multi-pin connectors directly.
- Wear electrically conductive clothing and antistatic shoes (with ESD symbol).
- For additional information see: 61 35 ... Notes for ESD protection (electrostatic discharge)



#### Damage to wires when disconnecting connectors and plug connections.

#### Sheared wires can cause a short circuit.

- Do not pull on the wires when disconnecting connectors and plug connections.



Follow instructions for removing and installing control units.

For additional information see: 12 00 ... Notes on removal and installation of control units



Disconnecting control units may cause fault code entries and functional limitations. Fault code entries must be read out and deleted if necessary.

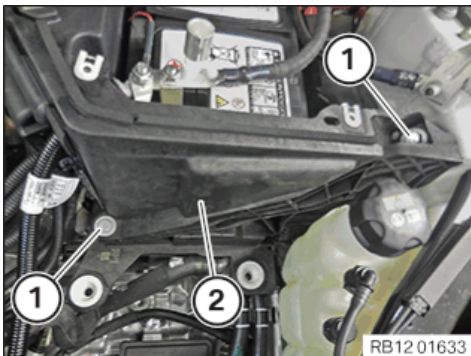

- Loosen screws (1).
- Guide out the tension strut (2) toward the top and remove it.

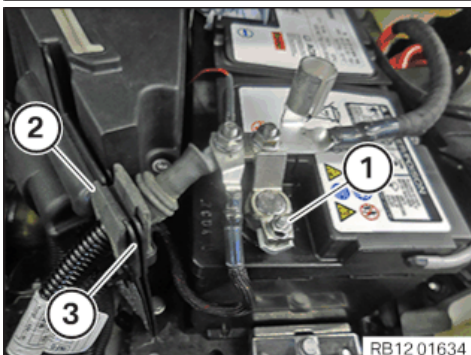

- Undo positive battery terminal (1).
- Feed out positive battery terminal (1) and set aside.
- Guide the positive battery cable (2) out of the holder (3) and lay to one side.

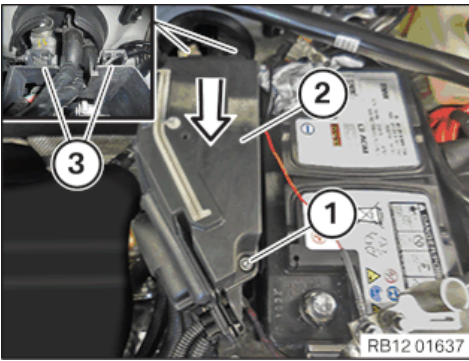

- Loosen screw (1).
- Unlock cover (2) and thread out and remove from the guides (3) in the direction of arrow.

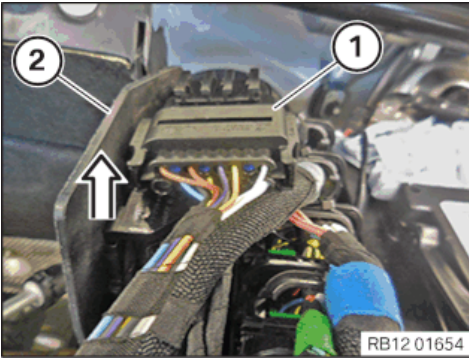

- Feed out and remove the plug connection (1) from the electronics box (2) in the direction of arrow.
- Unlock plug connection (1) and disconnect.

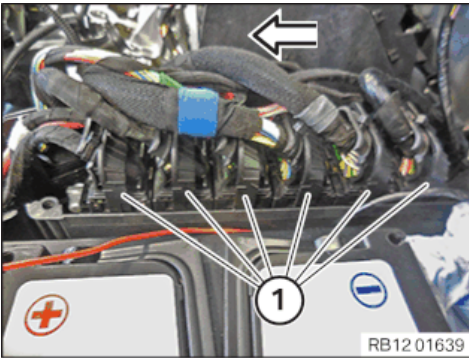

- Unlock and release the plug connections (1) in the direction of the arrow.
- Feed out connector (1) and place to one side.

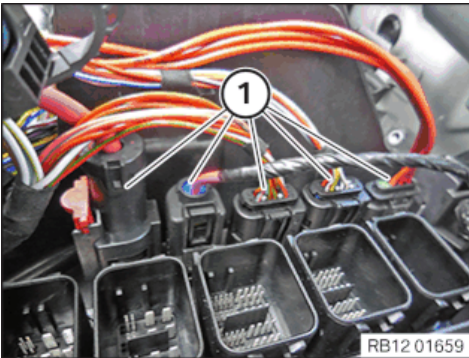

- Unlock plug connections (1) and disconnect.

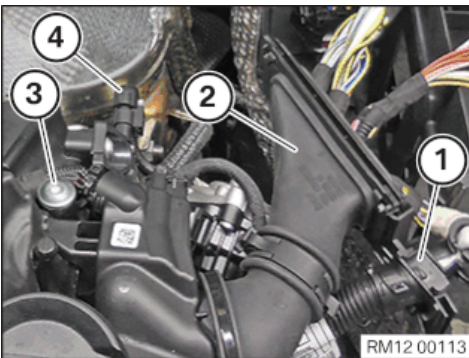

- Detach the wiring harness (1) from the electronics box.
- Detach the wiring harnesses (2) from electronics box.
- Loosen screw (3).
- Lay the wiring harnesses (1) and (2) to a side.
- Unlock the plug connection (4) and disconnect and pull off from the differential pressure sensor.

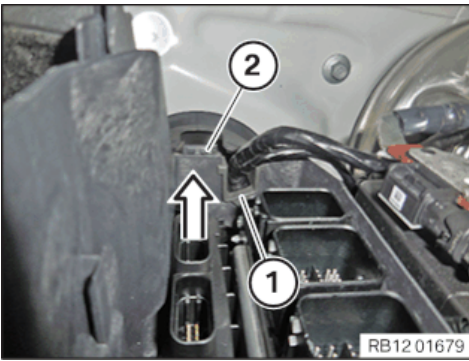

- Unlock and loosen holder (1).
- Guide the holder (1) out of the electronics box (2) in direction of arrow and set it aside.

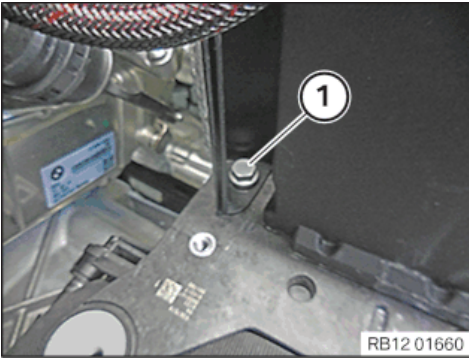

- Loosen screw (1).

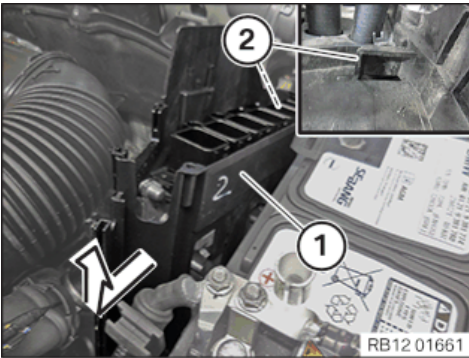

- Guide the electronics box (1) out of the guide (2) in direction of arrow and remove.

## 21 – Removing system battery



**Working on 12 V vehicle electrical system.**

**Risk of short circuits! Risk of fire!**

- Make sure that **no charger** is connected to the jump start support point in the engine compartment.
- Detach battery earth lead from battery.
- With auxiliary batteries: Detach all battery earth leads from additional batteries.

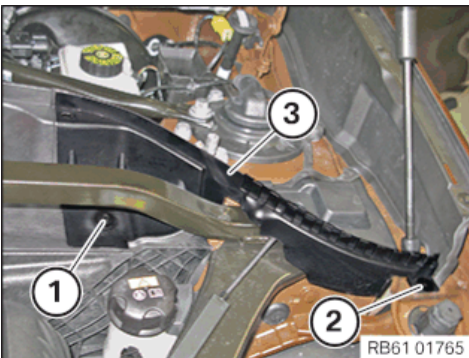

- Release the screw (1) and the expanding rivet (2).
- Remove the fixture for the gasket (3).

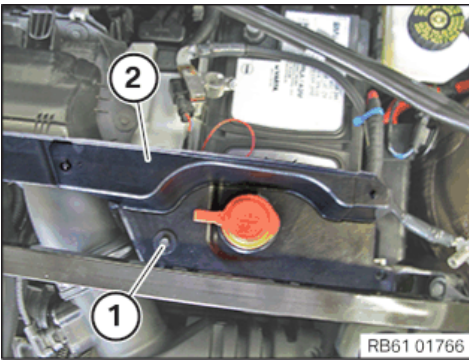

- Loosen screw (1).
- Remove the cover (2).

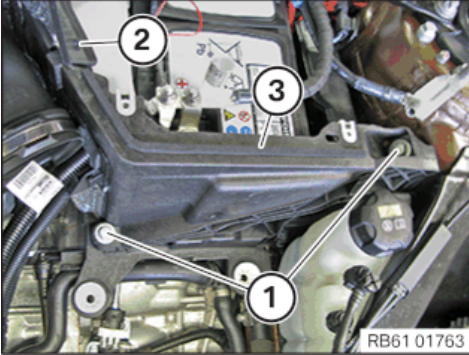

- Loosen screws (1).
- Unscrew the bolt (2) and guide the tension strut (3) out.

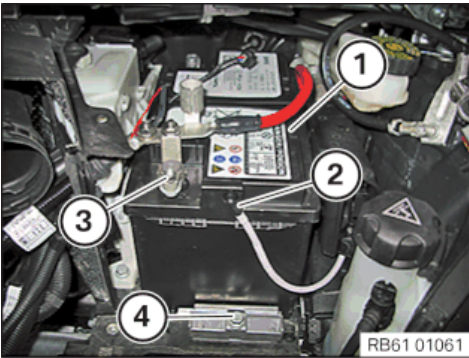

- Pull off the vent hose (2).
- Slacken the nut (3) on the positive battery terminal and remove the positive battery terminal.



**Unprotected battery terminals.**

**Risk of short circuits! Risk of fire!**

- Cover the vehicle battery.

- Loosen the screw (4) and remove the holder.
- Remove the system battery (1).

**22 – Remove battery holder**

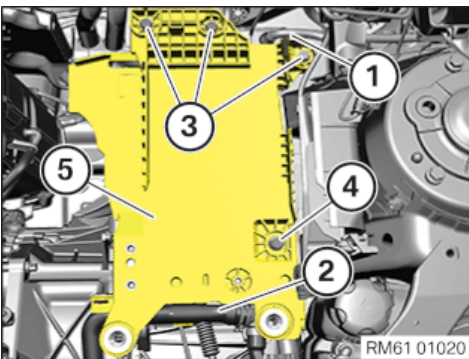

- Detach the cable clip (1) from the battery holder (5).
- Detach the coolant line (2) from the battery holder (5).
- Loosen screws (3).
- Loosen screw (4).
- Thread out and remove the battery holder (5).

**23 – Remove the rear bulkhead upper part**

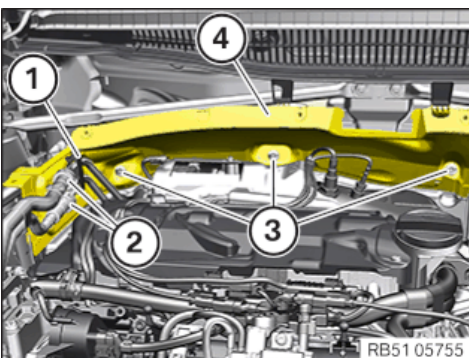

- Unlock holder (1) and disconnect.
- Guide out and remove the fuel lines (2).
- Loosen screws (3).
- Guide out the rear bulkhead upper part (4) and remove.

**24 – Remove the front left and right wheel**



Perform the operations on the left and right side.

### ► Removing the wheel



- If several wheels are removed simultaneously: Use a piece of chalk to mark on each tyre the axle and side on which the corresponding wheel is fitted.
- Unscrew the wheel bolts (arrows) and remove the wheel.

Use the matching adapter from tool set (wheel bolt adapter set) to loosen and tighten down the wheel bolt with security code.

## 25 – Removing front left and right wheel arch cover



Perform the operations on the left and right side.

### ► If installed: Release brake air duct



To provide a better overview: Schematic diagram with partially hidden components.



- Loosen screws (1).

### ► Remove front wheel arch cover



To provide a better overview: Schematic diagram with partially hidden components.

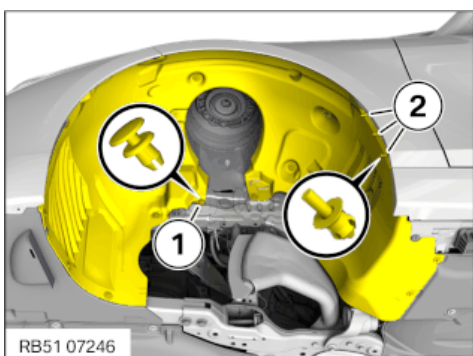

- Loosen expanding rivet (1).
- Loosen the expanding rivet (2).

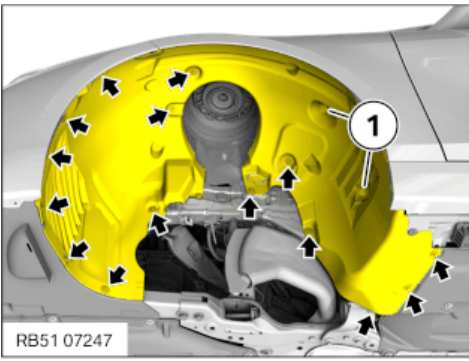

- Loosen nuts (1).
- Remove screws (arrows).
- Guide out and remove the front wheel arch cover.

## 26 – Remove the pressure pipe between the throttle body and the charge air cooler



**Hot surfaces.**

**Risk of burning!**

- Perform all work only on components that have cooled down.

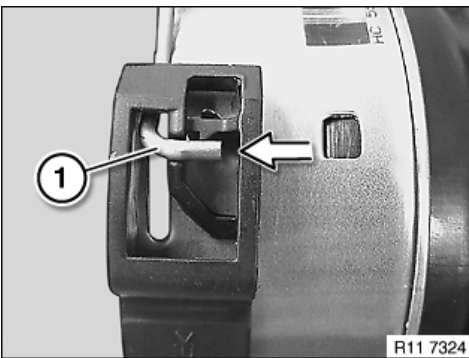

- Unlock lock (1).  
The lock (1) must engage in the bracket (arrow).

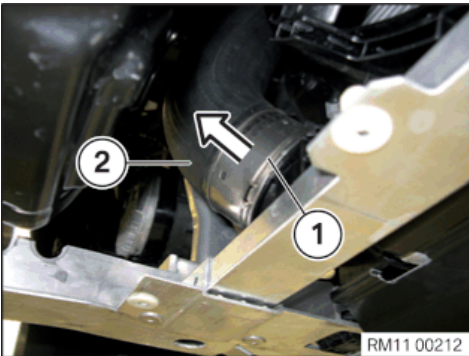

- Unlock and detach the locks (1) on both sides.
- Guide out the pressure pipe (2) in the direction of the arrow and set it aside.

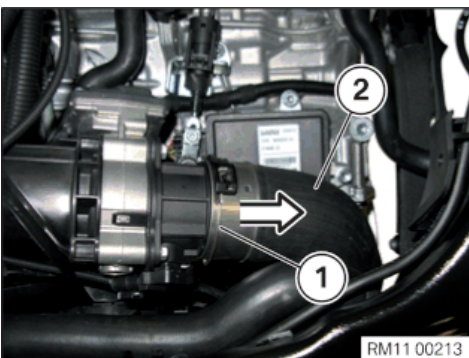

- Unlock and detach the locks (1) on both sides.
- Guide out the pressure pipe (2) in the direction of the arrow and set it aside.

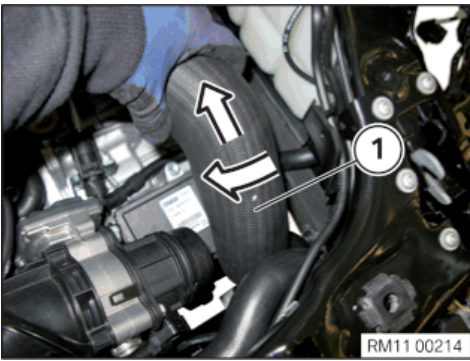

- Remove the pressure pipe (1) in the direction of the arrow.

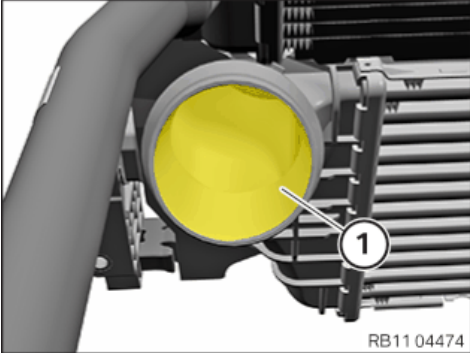

Schematic diagram is for example purposes. Some parts may differ in certain details.

- Lock the opening (1) of the charge air cooler with a suitable auxiliary material.

## 27 – Remove right charge-air line

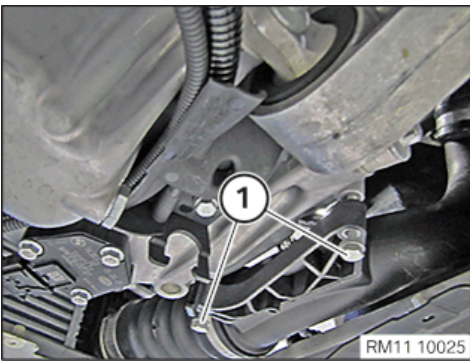

- Release charge air duct screws (1) on oil sump.

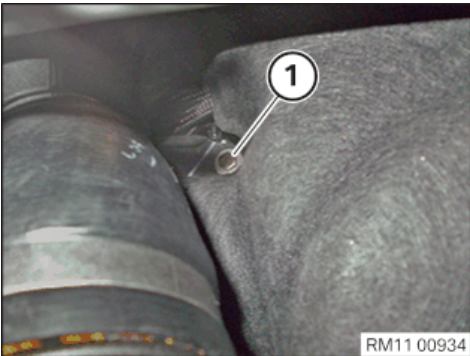

- Detach charge air duct screw connection (1) on crankcase.

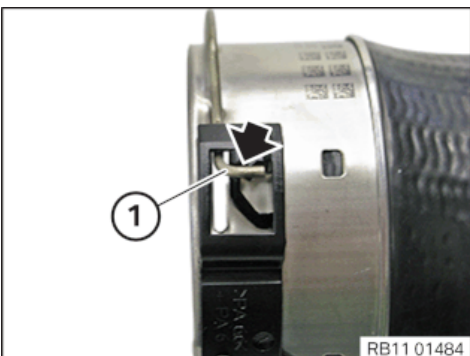

- Unfasten lock (1) on exhaust turbocharger and charge air cooler.
- Let the lock (1) engage at the holder (arrow).

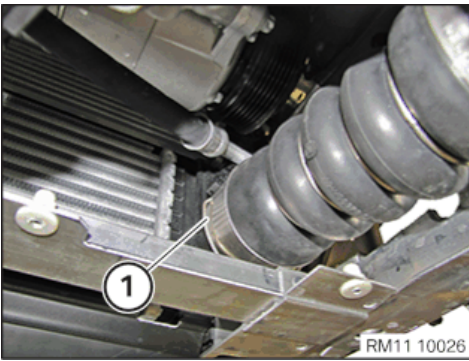

- Ensure that lock (1) on charge air cooler is unlocked on both sides.
- Detach charge air duct from charge air cooler.

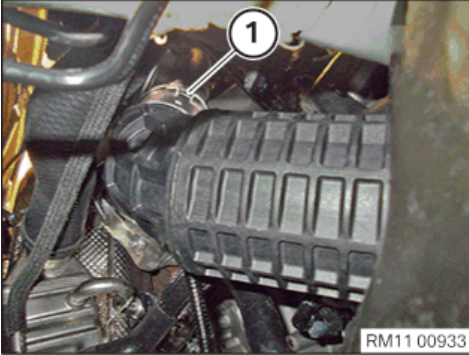

- Ensure that locks (1) from exhaust turbocharger are both unlocked.
- Pull charge air line from exhaust turbocharger.

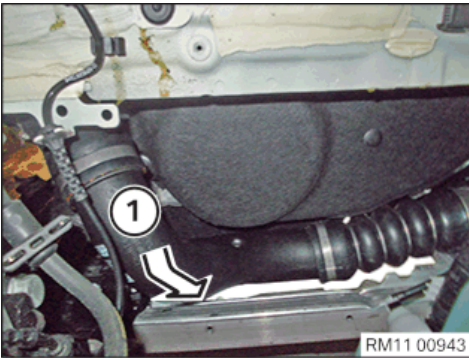

- Feed out and remove charge air line between side member and front axle support through the wheel arch downwards and to the side.

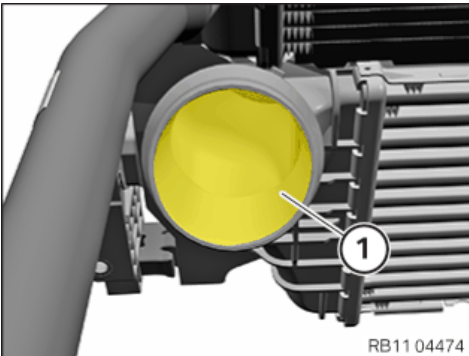

Schematic diagram is for example purposes. Some parts may differ in certain details.

- Lock the opening (1) of the charge air cooler with a suitable auxiliary material.

## 28 – Releasing lower steering shaft from steering gear



### Damage to steering column switch cluster (SZL).

The steering column switch cluster (SZL) or the coil spring cassette may be damaged by twisting of the steering wheel if the lower steering shaft (or the universal joint) is separated from the steering gear or from the steering column.

- After disconnecting the steering shaft (or the universal joint) from the steering gear or from the steering column, secure the steering wheel against twisting.

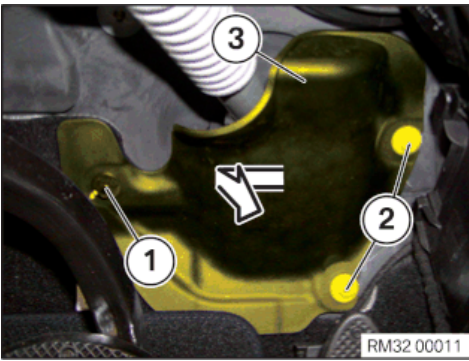

The following work step(s) is / are to be carried out if the specified component(s) is/are fitted.

- Loosen nut (1).
- Slacken the nuts (2).
- Feed out the cover (3) in the direction of arrow and remove it.

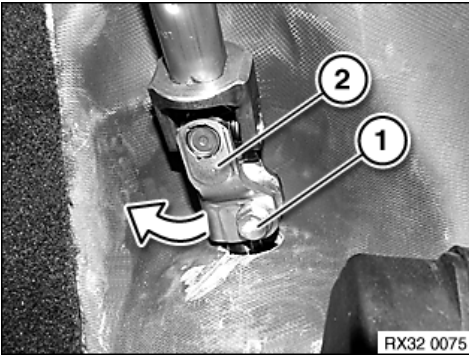

- Loosen screw (1).
- Release the universal joint (2) of the steering shaft at bottom in the direction of arrow from the steering gear and swivel it to the side.

### 29 – Fastening the coolant radiator on the left and right

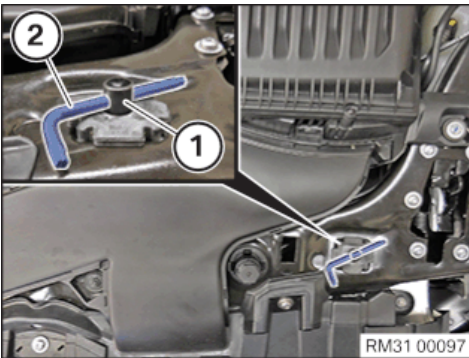

Perform the operations on the left and right side.

- Fasten the coolant radiator to centering pin (1) using a suitable tool (2).

### 30 – With right installation: Detaching ride height sensor cable

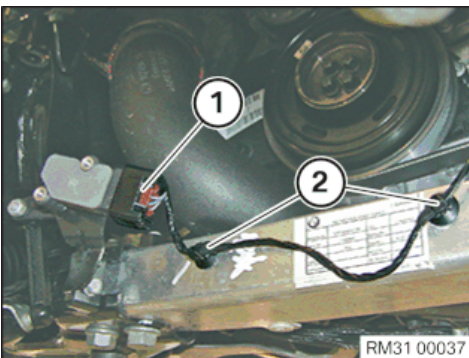

- Unlock plug connection (1) and disconnect.
- Release cable clip (2) from deformation element adapter.

### 31 – Releasing the left and right anti-roll bar from the anti-roll bar link



Perform the operations on the left and right side.

- ▶ Releasing the anti-roll bar from the anti-roll bar link

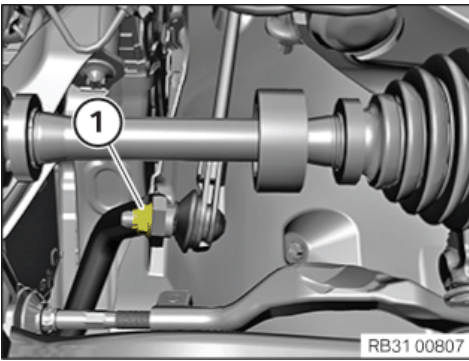

- Loosen nut (1).

**Note** Use the Torx socket for counter support.

- Loosen the anti-roll bar link from the anti-roll bar .

### 32 – Detaching rubber mount from front axle support

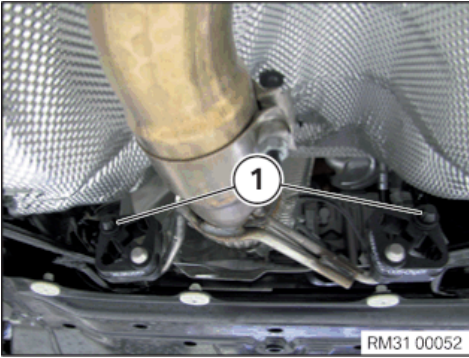

- Spray rubber mount (1) with lubricant and release from holder on front axle support.

### 33 – Disconnecting plug connections from steering gear

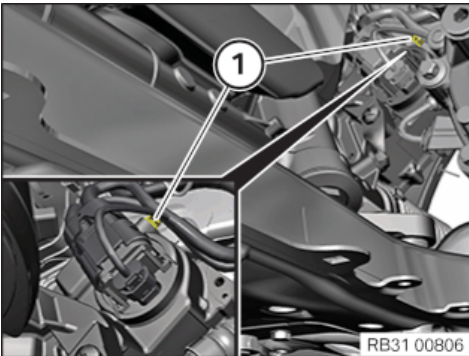

- Disconnect wiring harness (1) from steering gear.

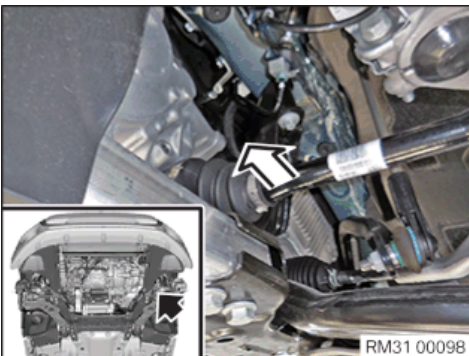

- To unlock the plug connections (see the following work step): Unlock plug connections with right hand in direction of arrow.

The plug connections can be reached via the left output shaft (arrow).

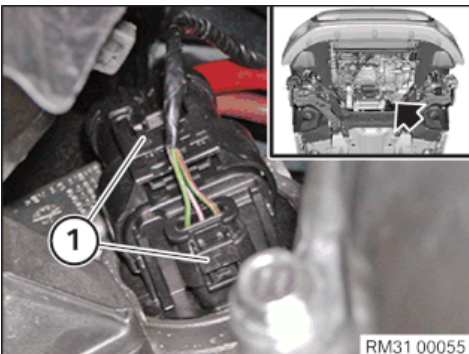

- Unlock plug connections (arrow) (1) and disconnect from the steering gear.
- Make sure when lowering the front axle that the cables are not damaged!

### 34 – Releasing the mounted part from the front axle support

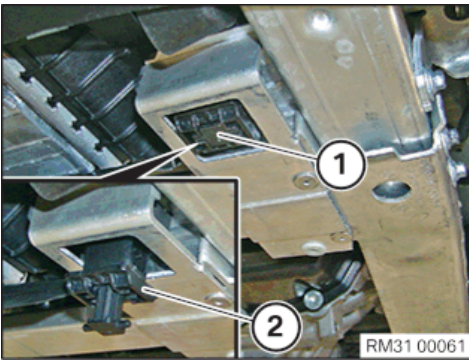

Perform the operations on the left and right side.

- Release the fuse (1) of the lock (2) from the charge air cooler holder.
- Remove the lock (2) completely.

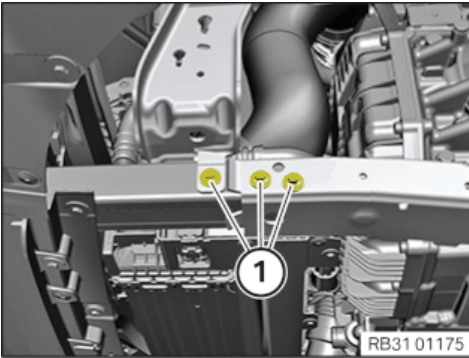

Perform the operations on the left and right side.

- Release the screws (1) on the deformation element.

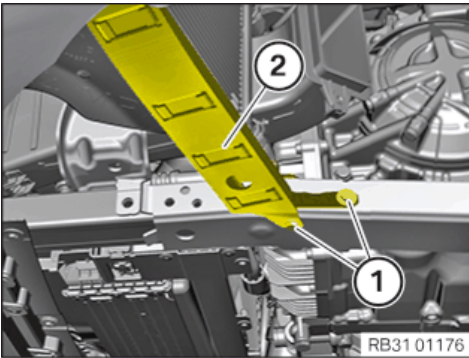

Perform the operations on the left and right side.



The following work step(s) is / are to be carried out if the specified component(s) is/are fitted.

- Loosen screws (1).
- Feed out and remove the holder (2) for external radiator.
- Release the screw (2).
- Release the holder with rubber mount (3) from the front subframe (1).

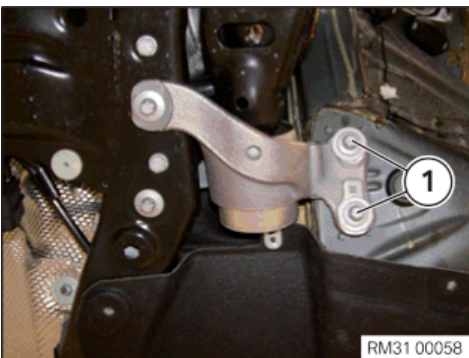
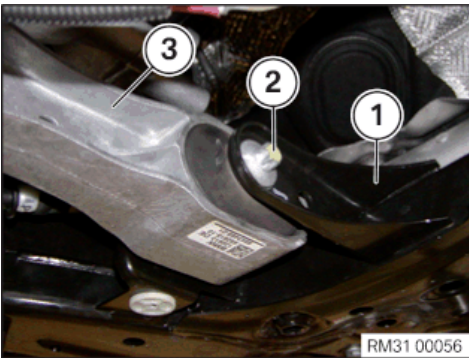

Perform the operations on the left and right side.

- Loosen screws (1).

### 35 – Remove front axle completely

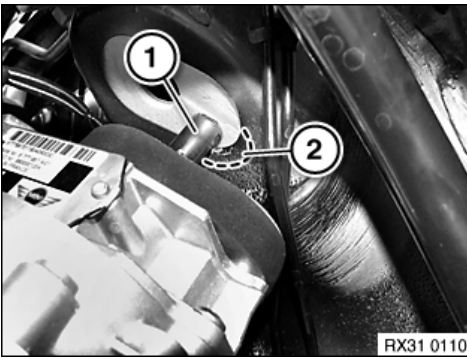

**Collision of the torsion bar of the EPS with the bulkhead.**

**Damage to the electromechanical steering gear (EPS)**

- When lowering and lifting the front axle support, ensure that the torsion bar of the electromechanical steering gear (EPS) does not collide with the bulkhead.

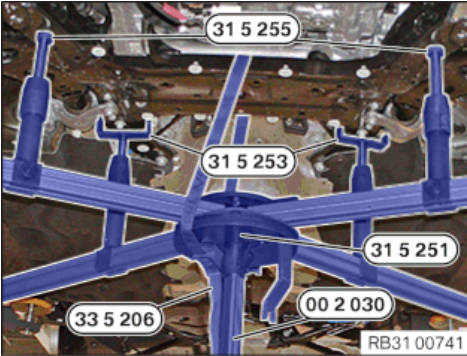

- Ensure that torsion bar (1) of the electromechanical steering gear (EPS) in area (2) does not collide with the bulkhead!
  - Align special tools and to front axle support.
  - Support the front axle support by operating the special tool **0 490 133 (00 2 030)**.
- Note** The centre of gravity of the front axle support must be positioned centrally over the workshop jack!
- Secure front axle support with special tool to special tool .

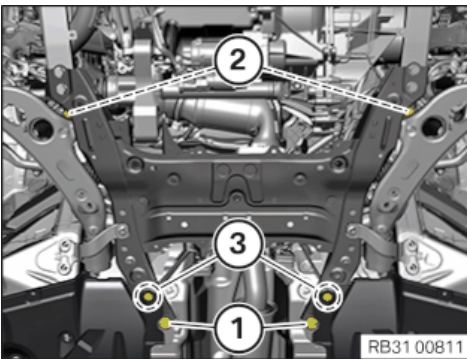

- Release screws (3) on the underbody panelling.
- Release screws (1) on the rear front axle support.
- Release the screws (2) on the front subframe at the front.
- Bend the underbody panelling in the areas of the screws (3) to the side.
- When lowering, feed out the rear front axle support on the underbody panelling and release the charge air cooler from the rubber mounts.
- Completely lower the front axle with the universal jack and remove.



Note the information on thread repairs using Helicoil thread inserts.

For more information see: 41 00 ... Notes on repairing threads

- Check thread for damage; if necessary, repair with Helicoil thread insert.

### 36 – Removing starter motor



**Hot surfaces.**

**Risk of burning!**

- Perform all work only on components that have cooled down.



**Working on 12 V vehicle electrical system.**

**Risk of short circuits! Risk of fire!**

- Make sure that **no charger** is connected to the jump start support point in the engine compartment.
- Detach battery earth lead from battery.
- With auxiliary batteries: Detach all battery earth leads from additional batteries.



## Electrostatic discharge.

### Damage to or destruction of electrical components.

- Leave electrical components in original packaging until just before they are installed. Use the original packaging only for any return shipments. Always package removed components straight away.
- Read and comply with user information on using the associated special tool 12 7 060.
- Only touch the housings of electrical components. Do not touch pins or multi-pin connectors directly.
- Wear electrically conductive clothing and antistatic shoes (with ESD symbol).
- For additional information see: 61 35 ... Notes for ESD protection (electrostatic discharge)

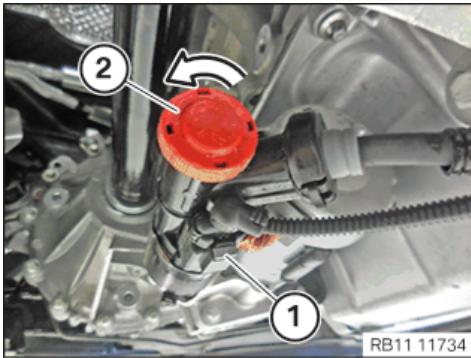

- Unlock and loosen connector (1).
- Detach the sealing cap (2) in the direction of the arrow.
- Feed out and remove the sealing cap (2).

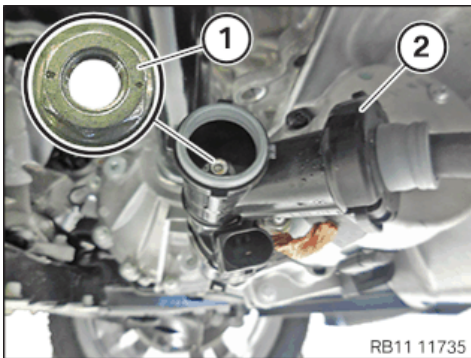

- Unfasten nut (1).
- Feed out the positive battery cable (2) of the starter motor and set it aside.

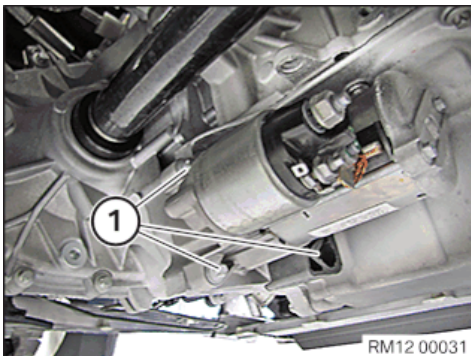

- Loosen screws (1).
- Feed out starter motor and remove.

## 37 – Remove right output shaft

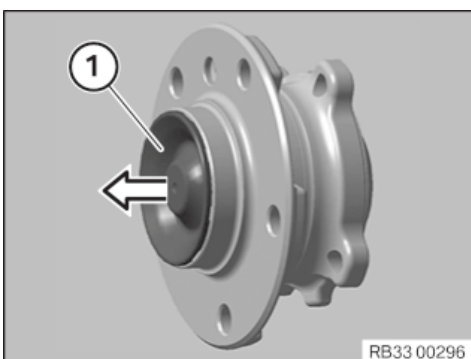

- If necessary, lever off the protective cap (1).

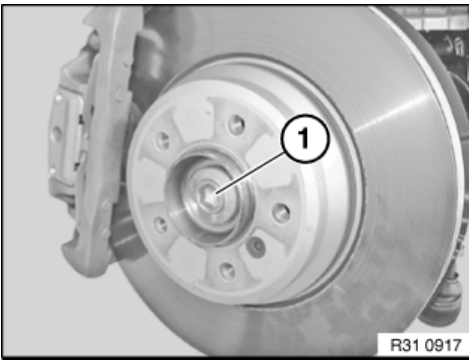

- Release collar bolt (1) by pressing the brake pedal up to the limit position.

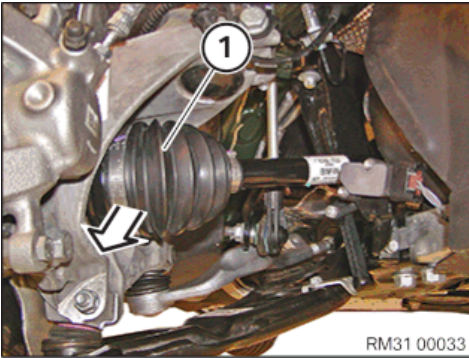

- Protect the output shaft (1) from falling.
- Turn steering wheel to right.
- Pull the output shaft (1) out.

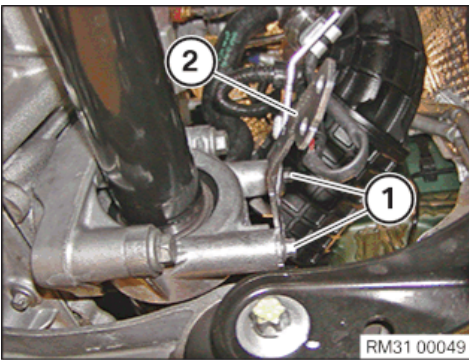

- If necessary, release the screws (1) and holder (heat shield) (2).

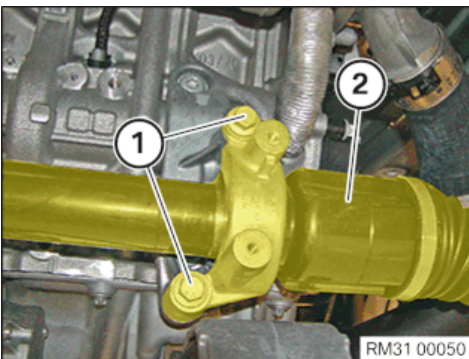

- Loosen screws (1).
- Pull out output shaft (2) from the transmission and remove it to the side.
- Remove output shaft (1).

### 38 – Remove left output shaft

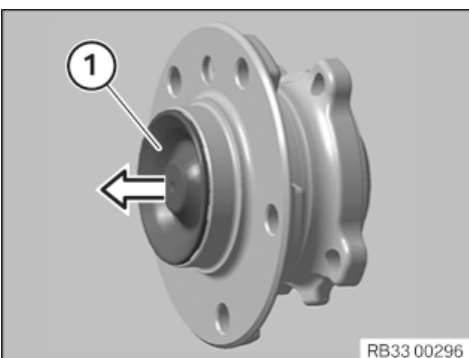

- If necessary, lever off the protective cap (1).

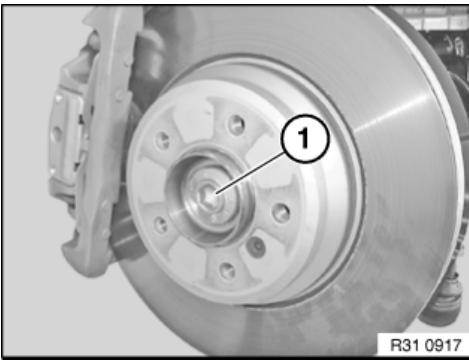

- Press the brake pedal to the floor to unscrew the collar bolt (1).

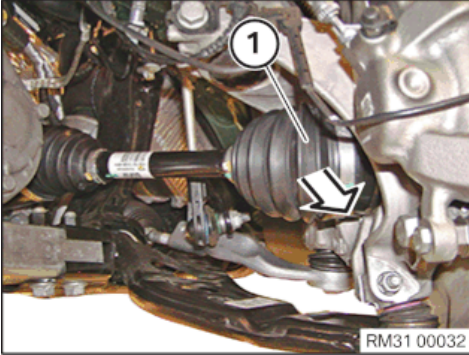

- Turn steering wheel to left.
- Pull the output shaft (1) out toward the front.

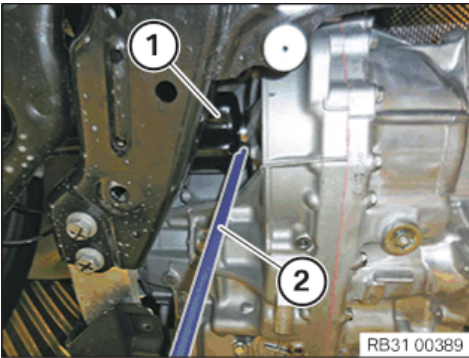

- Protect the output shaft (1) from falling.
- Lever out the output shaft (1) with a mounting lever (2) from the transmission.
- Remove output shaft (1).

### 39 – Remove the exhaust temperature sensor on the catalytic converter



**Hot surfaces.**

**Risk of burning!**

- Perform all work only on components that have cooled down.



**Electrostatic discharge.**

**Damage to or destruction of electrical components.**

- Leave electrical components in original packaging until just before they are installed. Use the original packaging only for any return shipments. Always package removed components straight away.
- Read and comply with user information on using the associated special tool 12 7 060.
- Only touch the housings of electrical components. Do not touch pins or multi-pin connectors directly.
- Wear electrically conductive clothing and antistatic shoes (with ESD symbol).
- For additional information see: 61 35 ... Notes for ESD protection (electrostatic discharge)

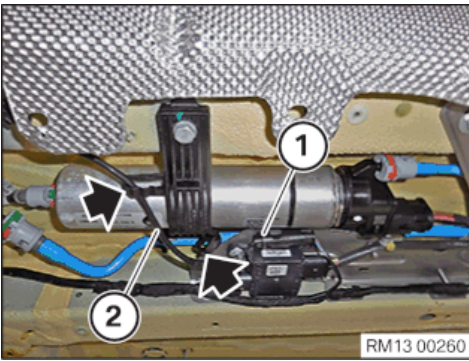

- Unlock and loosen connector (1).
- Feed out the cable (2) of the exhaust temperature sensor from the clamps (arrows) and remove.

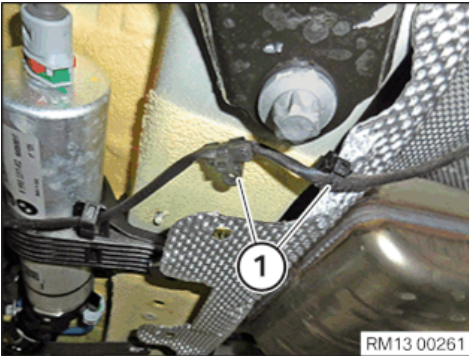

- Loosen the cable clip (1).

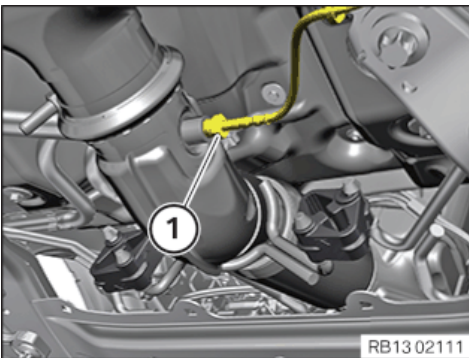

- Loosen exhaust temperature sensor (1).
- Feed out and remove exhaust temperature sensor (1).

#### 40 – Remove the SCR metering module



**Hot surfaces.**

**Risk of burning!**

- Perform all work only on components that have cooled down.



**Materials harmful to health.**

**Contact with fluids harmful to health!**

- Note and follow safety information on containers.
- Conduct all work in appropriate personal protective equipment only.



Collect and dispose of emerging fluids. Observe country-specific waste disposal regulations.



After repair work, clean the working area thoroughly with water.  
Clean special tools with water after every use.



Use only lint-free cloths for cleaning the SCR system: WAYPALL cleaning cloths L20 - see BMW Group Parts.



Notes on work at the cooling system form the basis of these repair instructions and must be complied with at all times.  
For additional information see: 17 00 ... Instructions for repair work on cooling system



Do not unintentionally swap the coolant hoses and coolant lines. If necessary, mark before removal.

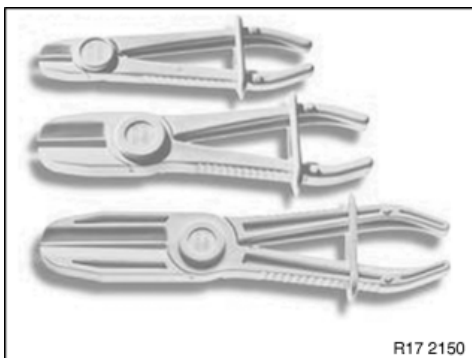

- Use commercially available pinch-off tools to pinch off the coolant hoses.

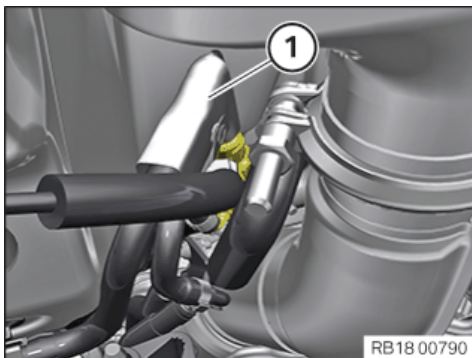

- Guide the heat protection cap (1) out and remove.

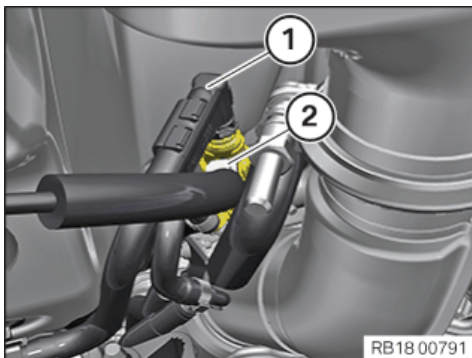

- When releasing the metering line, make sure that **no lateral forces** act on the metering line and the connection.  
The SCR metering module connection can be damaged by lateral forces.
- Unlock and disconnect the metering line (1).
- Unlock and disconnect connector (2).

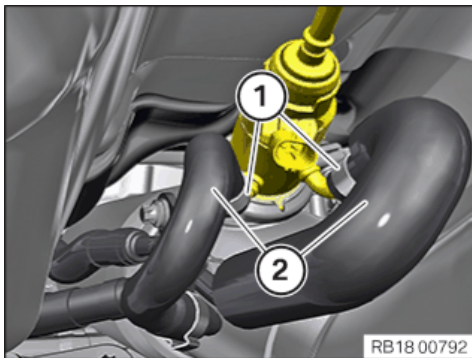

- Loosen clamps (1).
- Disconnect coolant lines (2).

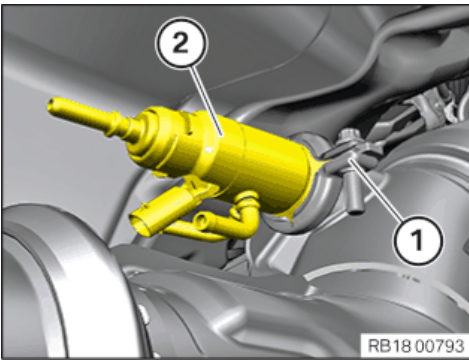

- Loosen V-band clamp (1).
- Guide out and remove the SCR metering module (2).

## MAIN WORK

### 41 – Removing engine



- Unlock and pull off the fuel lines (1).

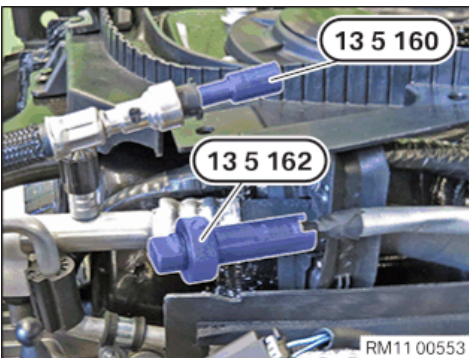

- Seal fuel lines with special tools and .

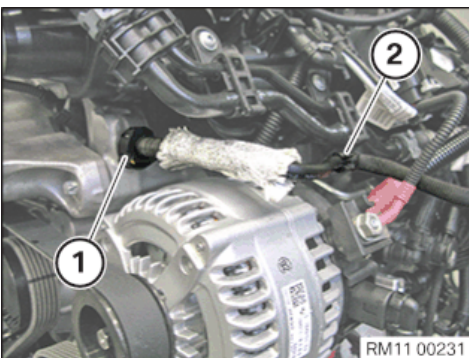

- Unlock the clamp (1).
- Pull off the coolant line (2) from the cylinder head.

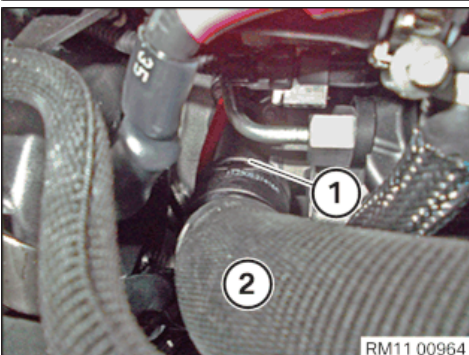

- Unlock lock (1) upwards and pull off coolant hose (2).
- Catch and dispose of escaping coolant.

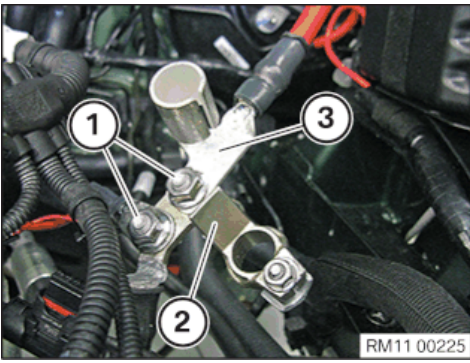

- Loosen nuts (1).
- Feed out the positive battery terminal (2) and the remote positive terminal (3) and set aside.

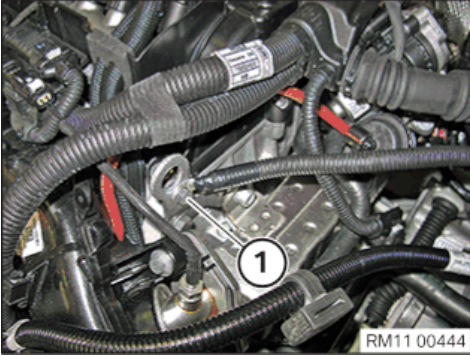

- Unscrew the bolt (1) and set the ground strap aside.

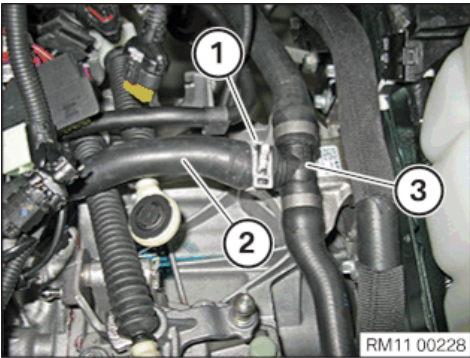

- Detach the clamping collar (1).
- Detach the coolant hose (2) from the coolant line (3).
- Catch and dispose of escaping coolant.

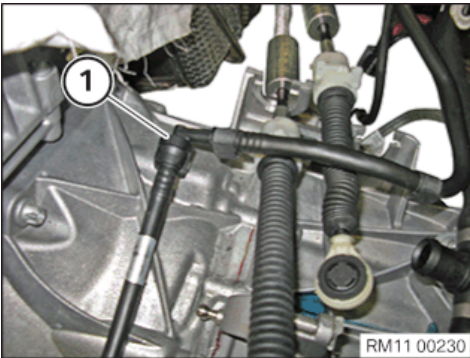

- Unlock and disconnect the vacuum line (1).

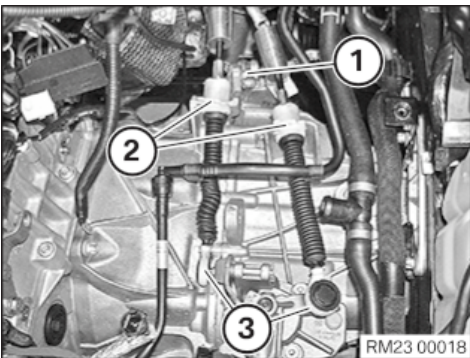

- Release screw (1) and guide out the ground strap and set it aside.
- Unlock safeguards (2) on the holders of the gear selector cables and remove.
- Lever fixtures (3) of the gear selector cables with an AF 13 open-end spanner off the ball joints.

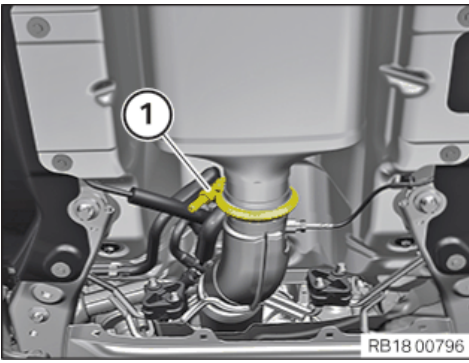

- Loosen V-band clamp (1).
- Release exhaust system from diesel particulate filter.

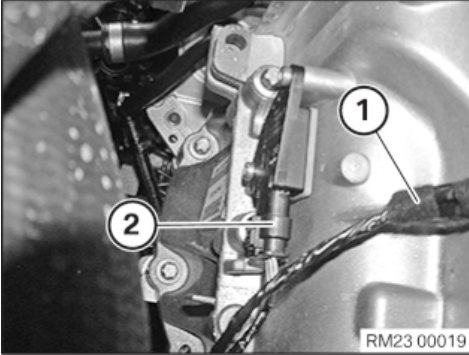

- Unlock plug connection (2) and disconnect.
- Release cable (1) with the holder from the transmission.

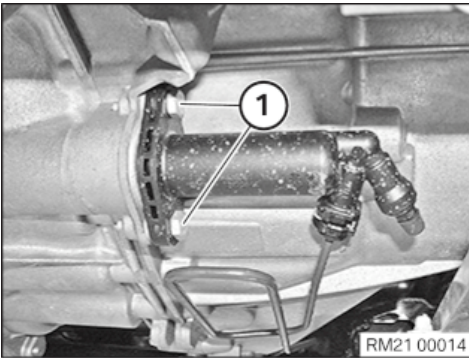

- **Ensure that the clutch slave cylinder remains connected to the pressure line.**
- Loosen screws (1).
- **Slowly** release clutch slave cylinder and remove.

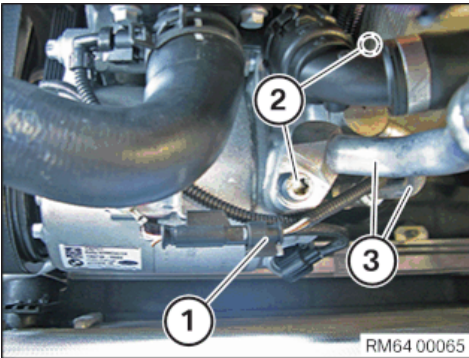

**Residual pressure in the air conditioning.**

**Danger of injury!**

- Wear safety goggles and protective gloves when disconnecting the refrigerant line.
- Seal refrigerant lines with seal plugs.

- Unlock plug connection (1) and disconnect.
- Loosen screws (2).
- Feed out the refrigerant lines (3) and set them aside.
- Close the openings on the refrigerant lines (3) and the air conditioning compressor with standard tools.

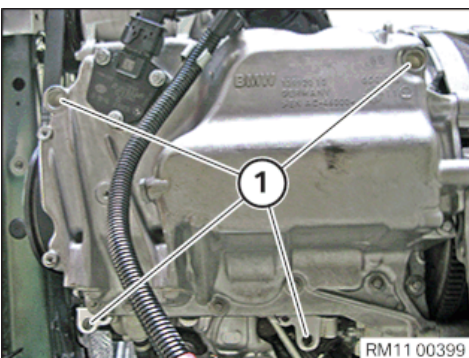

- Ensure that the **40/50** distance pins of table top **A** of the mobile lifting table are installed in mounting points (1) of the oil sump.

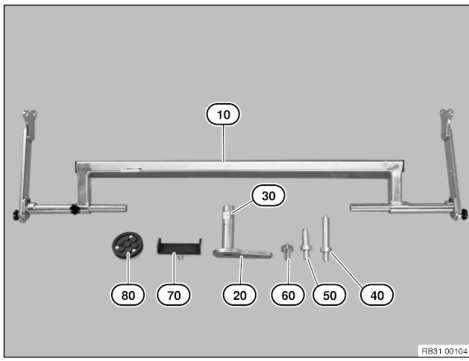

- Overview of the set of special tools **2 305 379**:

Number	Description
10	For mounting swivel bearing with brake disc
20	Retaining element for adjustable fixture
30	Adjustable fixture
40	Distance pin 40 x 160 mm
50	Distance pin 40 x 110 mm
60	Distance pin 40 x 60 mm
70	Fixture with U-profile
80	Plate mounting 100 mm

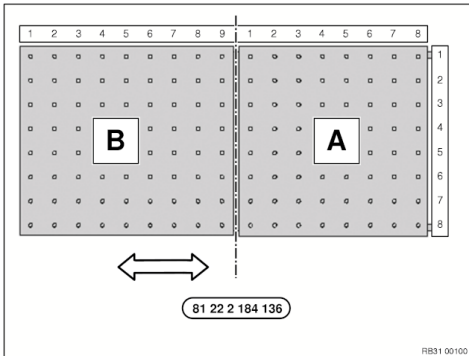

- Overview of special tools **2 184 136**:

Letter	Description
A	Table top for engine with coordinates
B	Table top for transmission with coordinates

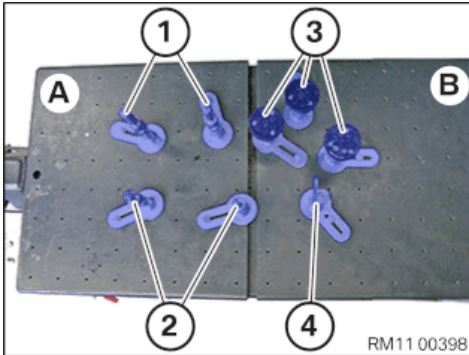

- Position adjustable fixture (30) with distance pin (40) for the engine block on table top (A) at the coordinates **5/6** and **1/7** (1).
- Position adjustable fixture (30) with distance pin (50) for the engine oil sump on table top (A) at coordinates **5/3** and **2/3** (2).
- Position adjustable fixture (30) with distance pin (80) for the transmission housing on table top (B) at coordinates **6/5**, **2/5** and **2/7** (3).
- Position adjustable fixture for transmission housing on table top (B) at coordinates **6/3** (4).

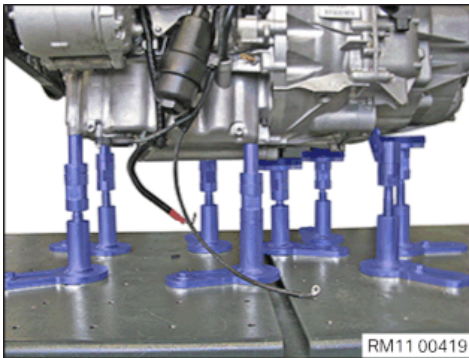

- Position the lifting table below the engine.
- Abut all fixtures and screw them to the lifting table.

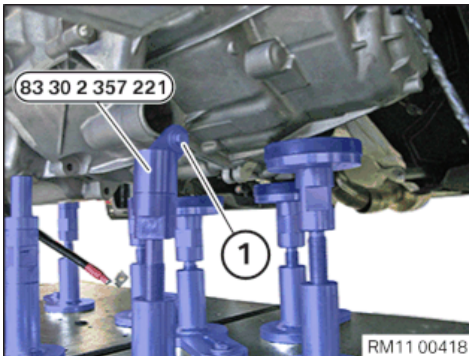

- Attach the adjustable fixture to the housing of the clutch slave cylinder with screw (1).

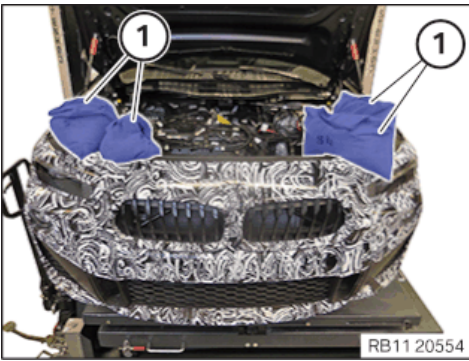

**Motor vehicle may slip off the vehicle hoist if the weight is distributed unevenly.**

**Danger! Life-threatening injuries!**

- Ensure there is a specific weight compensation on the motor vehicle.
- Position the weight compensation (1) on the vehicle.

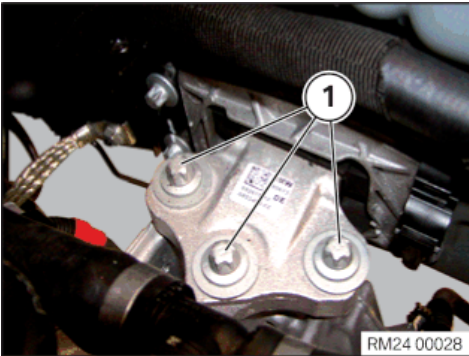

**Motor vehicle may slip off the vehicle hoist if the weight is distributed unevenly.**

**Danger! Life-threatening injuries!**

- Ensure there is a specific weight compensation on the motor vehicle.
- Loosen screws (1).

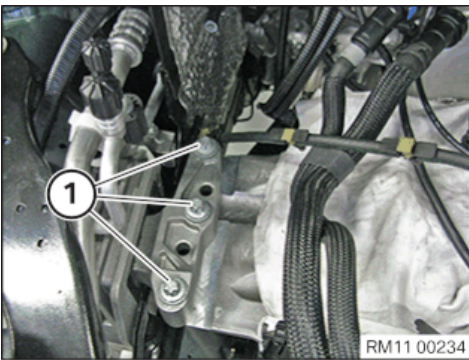

**Vehicle may slip off the vehicle hoist if the vehicle hoist is handled incorrectly.**

**Danger! Life-threatening injuries!**

- Observe safety information on raising the vehicle using a vehicle hoist.
- For additional information see: 00 ... Raise the vehicle using a vehicle lift.
- Loosen screws (1).
- Raise the vehicle **carefully**.

## 42 – Install engine

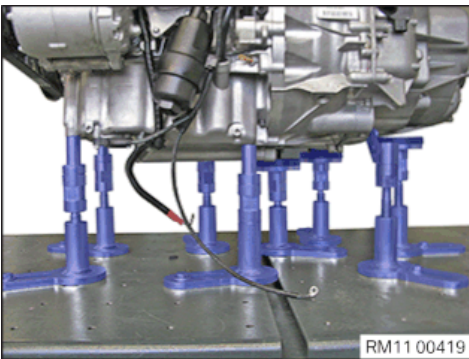

**Motor vehicle may slip off the vehicle hoist if the weight is distributed unevenly.**

**Danger! Life-threatening injuries!**

- Ensure there is a specific weight compensation on the motor vehicle.



**Vehicle may slip off the vehicle hoist if the vehicle hoist is handled incorrectly.**

**Danger! Life-threatening injuries!**

- Observe safety information on raising the vehicle using a vehicle hoist.
- For additional information see: 00 ... Raise the vehicle using a vehicle lift.
- Position the lifting table and the engine under the vehicle.
- **Carefully** lower the vehicle and, if necessary, position the lifting table **correctly** for the vehicle.

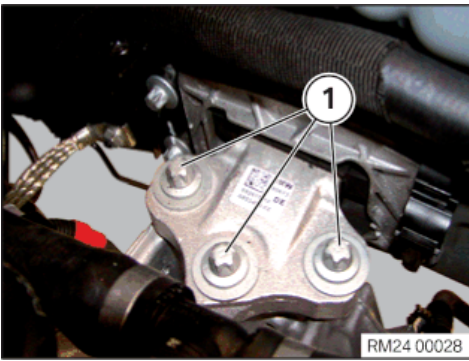

RM24 00028

- Renew screws (1).
- Tighten the screws (1).

**Parts:** Bolts

**Transmission mounting**

M10	Renew screws.	Jointing torque	40 Nm
		Angle of rotation	90 °

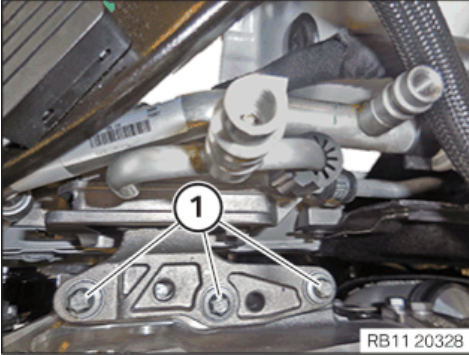

RB11 20328

- Renew screws (1).
- Tighten the screws (1).

**Parts:** Bolts

**Right engine mount to cylinder head**

M10	Renew screws.	Jointing torque	40 Nm
		Angle of rotation	90 °

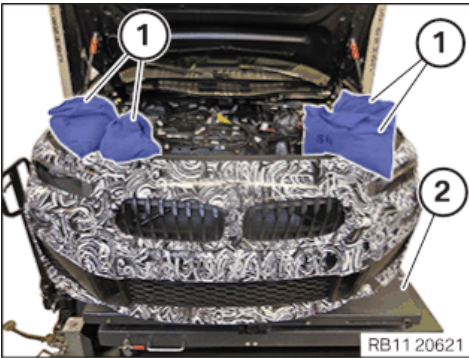

RB11 20621



**Motor vehicle may slip off the vehicle hoist if the weight is distributed unevenly.**

**Danger! Life-threatening injuries!**

- Ensure there is a specific weight compensation on the motor vehicle.

- Remove weight compensation (1) from the vehicle.
- Lower lifting table(2) and put to one side.
- Replace the sealing ring (1) on the coolant lines (2).

**Parts:** Sealing ring

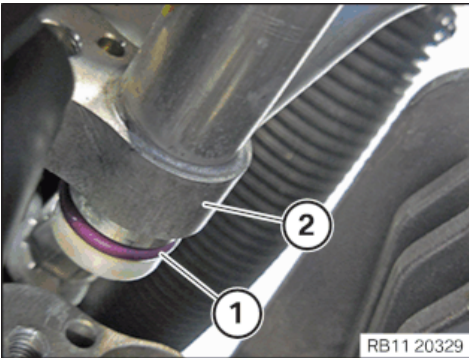

RB11 20329

- Feed in and install the refrigerant lines (3).
- Tighten down screws (2).

**Refrigerant line on air conditioning compressor**

M8		Tightening torque	19 Nm
----	--	-------------------	-------

- Connect connectors (1) and lock.
- Make sure the connector (1) engages audibly.

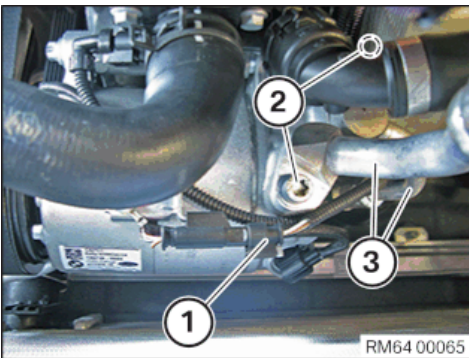

RM64 00065

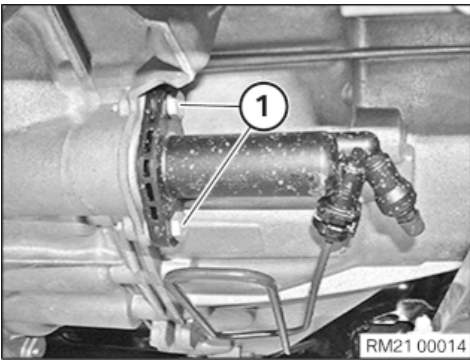

- Feed in and install the clutch slave cylinder .
- Tighten the screws (1).

**Clutch slave cylinder to transmission housing**

M8

Tightening torque

19 Nm

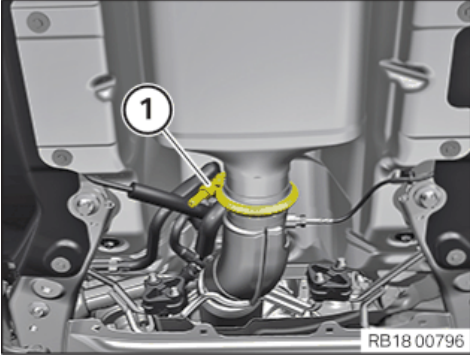

- Connect exhaust system to the diesel particulate filter.
- Feed in and install V-band clamp (1).

**► Install the V-clip**

**V-band clamp**

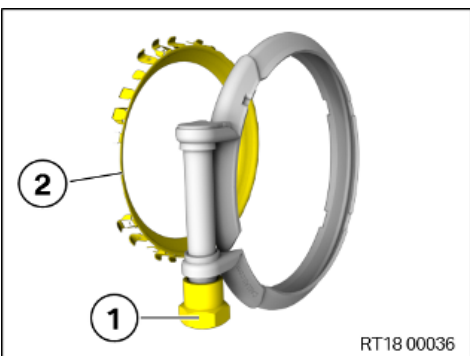
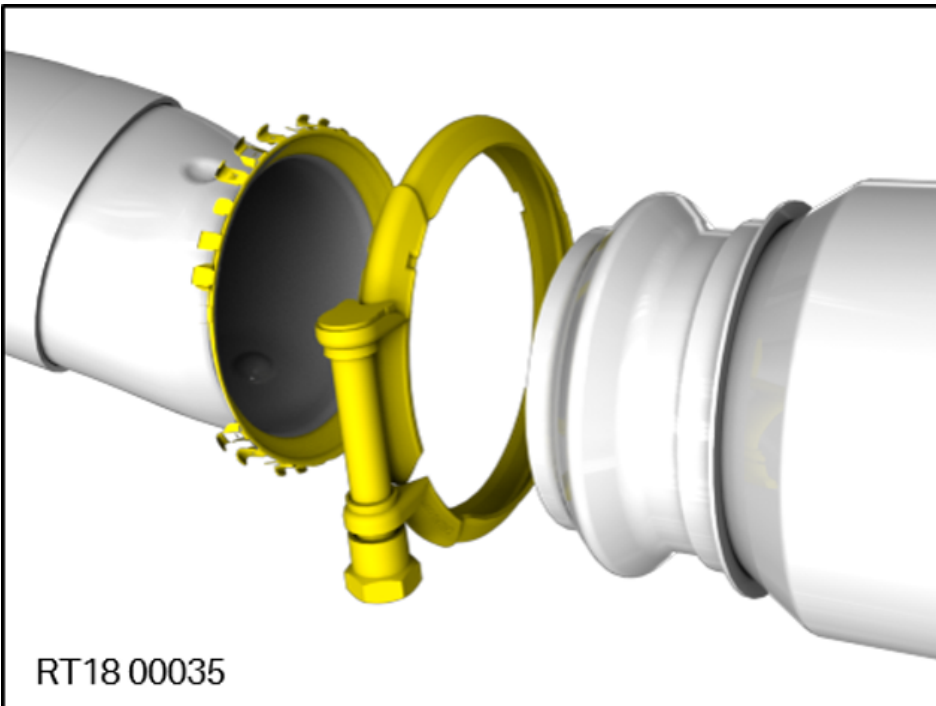

- Unscrew the nut (1) and remove the sealing ring (2).

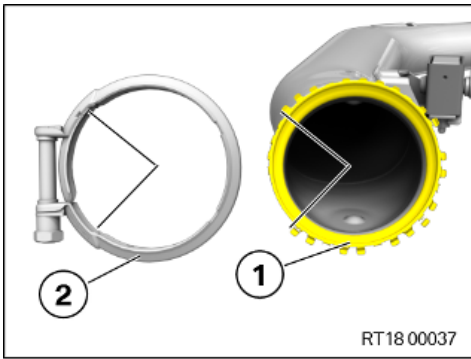

- Renew the V-clip (2).
- **Parts:** V-band clamp
- Mount the sealing ring (1) on the exhaust system.
- Ensure that the sealing ring (1) for the V-clip (2) is positioned correctly.

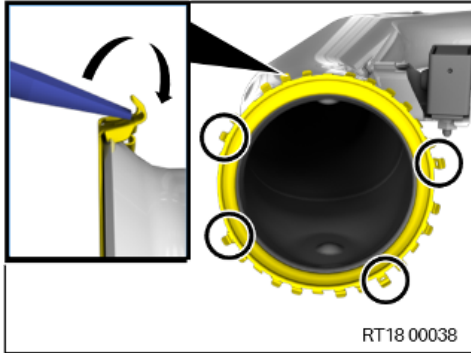

- Bend all sheet metal tabs over with a suitable tool, except those in the marked areas.

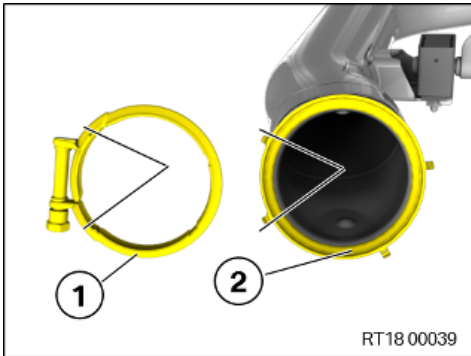

- Mount the V-clip (1) on the sealing ring (2).
- Make sure that the V-clip (1) is positioned correctly on the sealing ring (2).

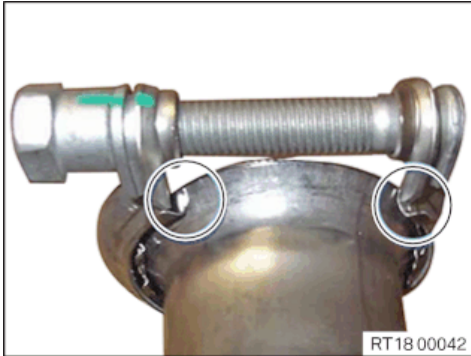

- Make sure that the V-clip rests against the sheet metal tabs after mounting (marks).

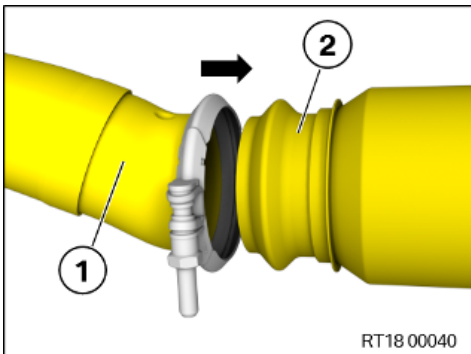

- Connect the exhaust system (1) with the catalytic converter (2) in the direction of arrow and position correctly.

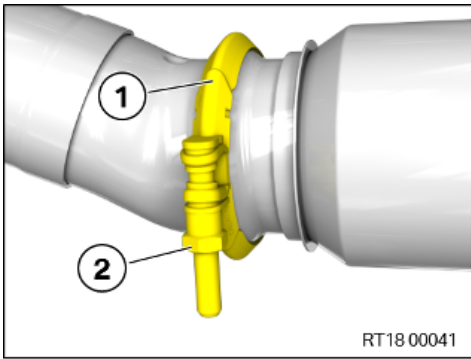

- Make sure that V-clip (1) is fitted correctly.
- Tighten down screw (2).

**V-clip to catalytic converter**

V-band clamp	Renew V-band clamp.	Tightening torque	25 Nm
--------------	---------------------	-------------------	-------

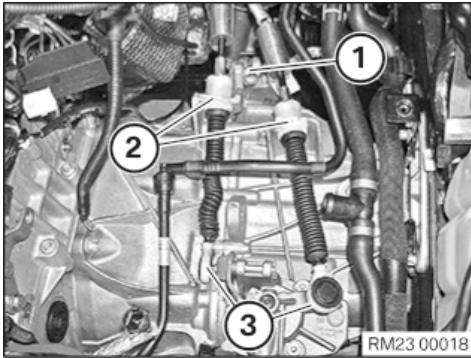

- Insert earth strap and tighten the screw (1).

**Standard screw connection M8**

M8		Tightening torque	19 Nm
----	--	-------------------	-------

- Attach fixtures (3) of gear selector cables to the ball joints and engage.
- Insert gear selector cables in the holders and secure in the holders with safeguards (2).

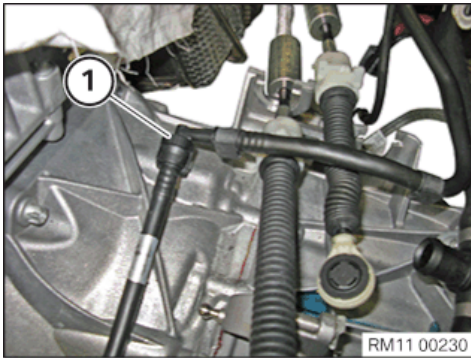

- Connect the vacuum line (1) and lock.
- Make sure you can hear the vacuum line (1) engage.

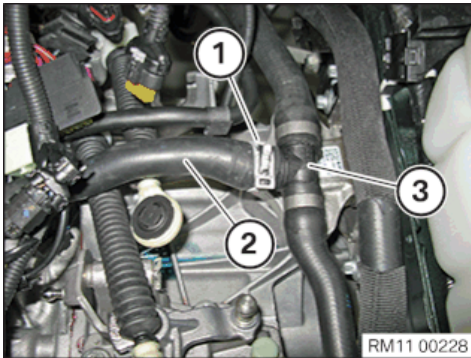

- Insert and install the coolant hose (2) on the coolant line (3).
- Fasten the clamping collar (1).

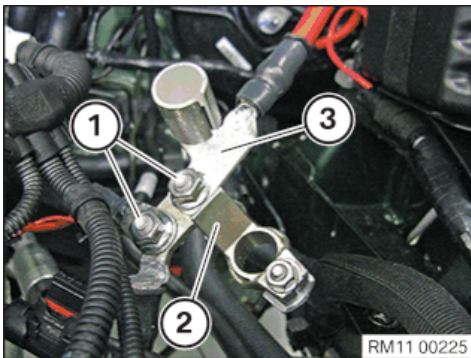

- Insert and install the positive battery terminal (2) and the remote positive terminal (3).
- Tighten nuts (1).

**Positive battery cable to positive battery terminal**

M8		Tightening torque	15 Nm
----	--	-------------------	-------

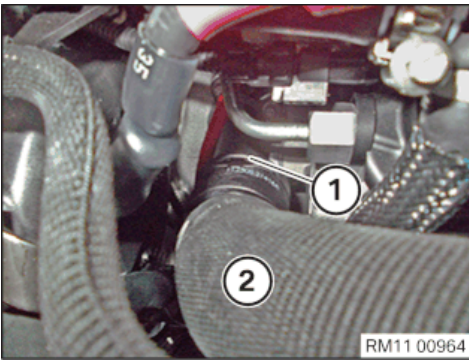

- Connect and lock the coolant lines (2).
- Ensure that the lock (1) engages audibly.

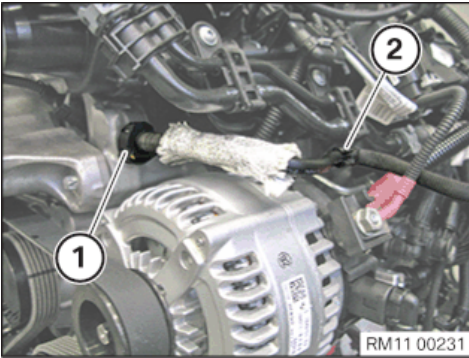

- Connect the coolant line (2).
- Lock clamp (1).

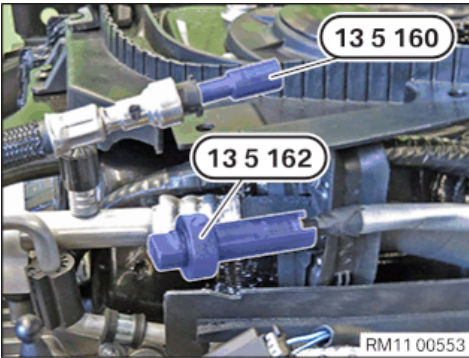

- Thread out special tools and remove.



- Route and connect fuel lines (1).
- Ensure that the lock engages audibly.

## POSTPROCESSES

### 43 – Installing the SCR metering module

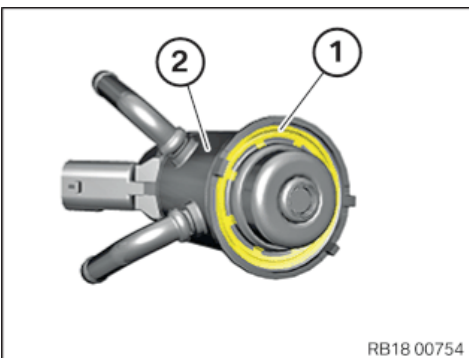

The work must be performed with care to prevent component damage.



**Improper removal of the seal of the SCR metering module.  
Damage to the sealing surface, leak in the SCR metering module.**

- Carefully remove the seal.

- Remove seal (1) **with care** from SCR metering module (2).

**It is absolutely essential to ensure that sealing surface on SCR metering module (2) is not damaged.**

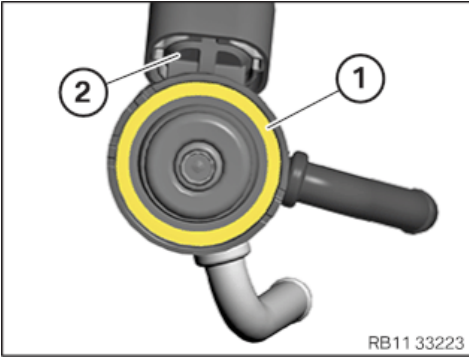

**Check**

- Check sealing surface (1) of the SCR metering module (2) for damage.

**Result**

Sealing surface (1) is **damaged**.

This results in a **leak** at SCR metering module (2).

**Measure**

- Renew SCR metering module (2).

**Result**

Sealing surface (1) is **not damaged**.

**Measure**

- Continue with the next work step.

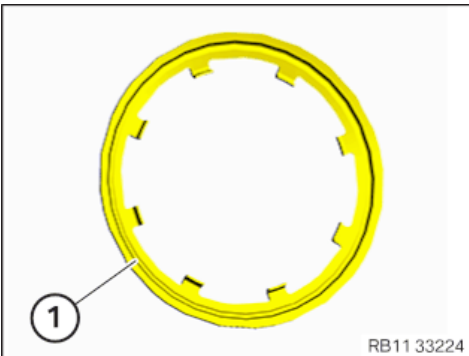

- Renew seal (1).

**Parts:** Gasket

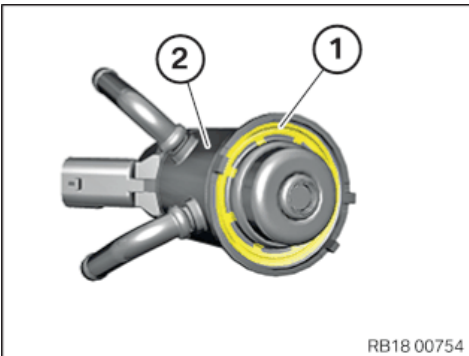

- Mount seal (1) on SCR metering module (2).

► **Checking the screw connection of the V-clips**

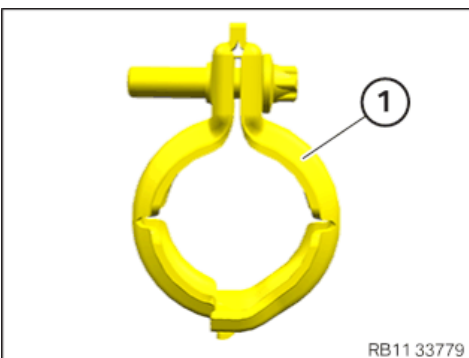

The V-clip **must** be renewed! Reuse is not permitted.

- Renew V-clip (1).

**Parts:** V-band clamp

**Check**

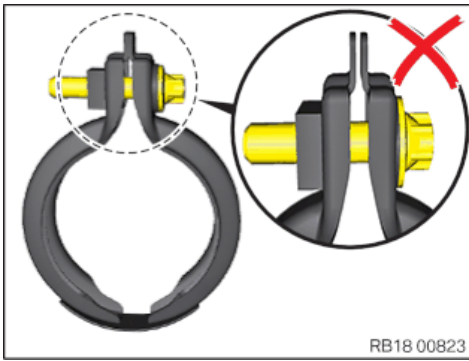

RB18 00823

- Check if the screw connection of the V-band clamp is too loose.

**Result**

The screw connection is too slack. A gap can be seen between the ends of the V-clips.

**Measure**

- Loosen the screw and tighten again.

**Check**

- Check if the screw connection of the V-band clamp is too tight.

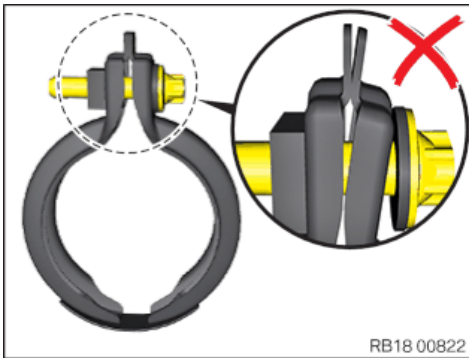

RB18 00822

**Result**

The screw connection is too tight. The ends of the V-clip are not positioned parallel.

**Measure**

- Release the screw and renew V-clip.

**Parts:** V-band clamp

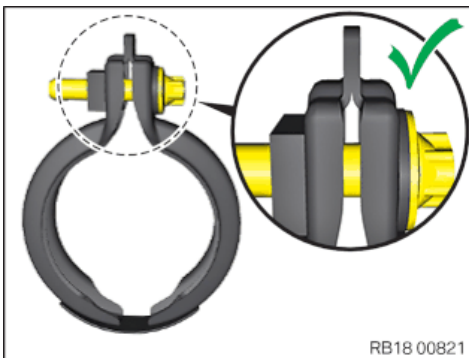

RB18 00821

- Make sure that the ends of the V-band clamp are parallel to each other.

**Check**

- Check the coolant lines (1) in the marked area for damage caused by the clamp.

**Note** Bend the coolant lines back and forth slightly to see the damage better.

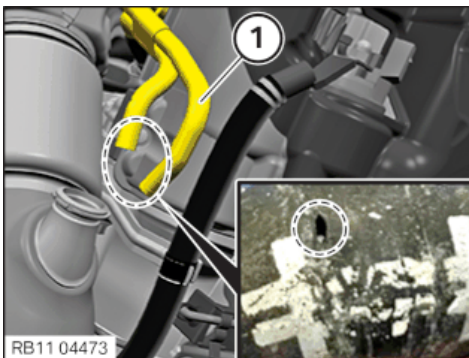

RB11 04473

**Result**

Coolant lines (1) are damaged.

**Measure**

- Drain the coolant and renew the coolant lines (1) for the SCR metering module.



- In order to mount the clamps onto the SCR metering module, use only the special tool .
- Compress the clamps on the marked, slightly open side (arrows).  
The clamp is crimped correctly when the gap is **less than 1 mm**.

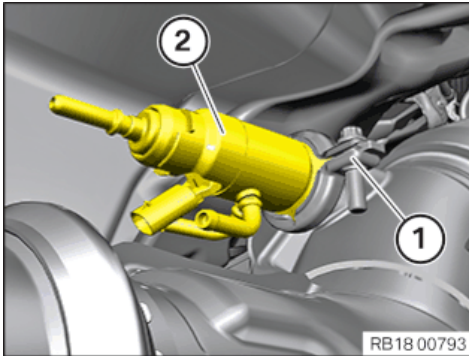

- Insert and install the SCR metering module (2).
- Renew the V-clip (1).  
**Parts:** V-band clamp
- Tighten V-clip (1).

#### SCR metering module V-clip to exhaust system

V-band clamp	Renew V-band clamp.	Tightening torque	8 Nm
--------------	---------------------	-------------------	------

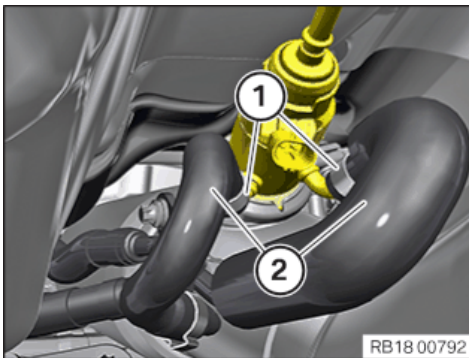

- Connect the coolant lines (2).
- Renew the clamps (1).  
**Parts:** Clamps
- Fasten the clamps (1).

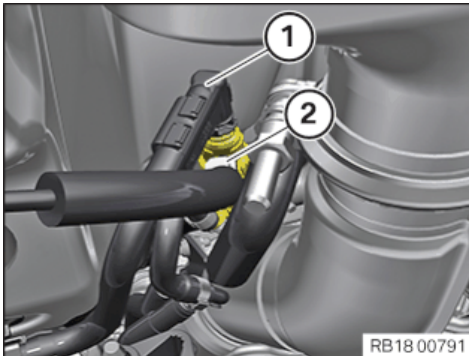

- Connect connectors (2) and lock.  
The connector (2) must engage audibly.
- Connect and lock the metering line (1).  
Metering line (1) must engage audibly.

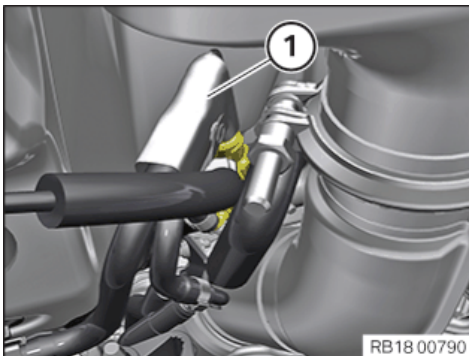

- Insert and install the heat protection cap (1).

## 44 – Installing exhaust temperature sensor on catalytic converter

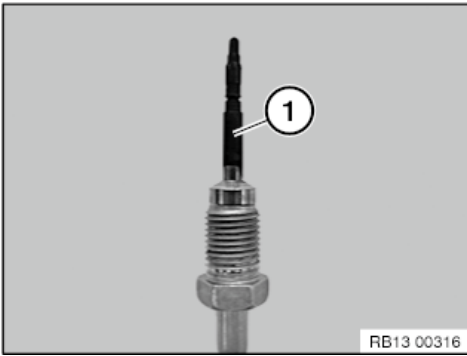

**Damage of exhaust temperature sensor.**  
**Damage to exhaust temperature sensors leads to malfunctions.**

- Make sure that the gauge tip is not damaged.

- Check the gauge tip (1) for damage and replace the exhaust temperature sensor as needed.

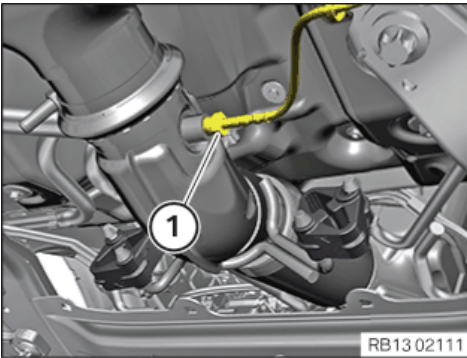

- Feed in and install the exhaust temperature sensor (1).
- Tighten the exhaust temperature sensor (1).

**Exhaust-gas temperature sensor to exhaust system**

Exhaust-gas temperature sensor	Tightening torque	28 Nm
--------------------------------	-------------------	-------

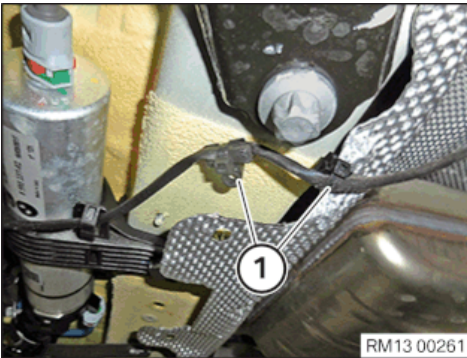

- Secure the cable clips (1).

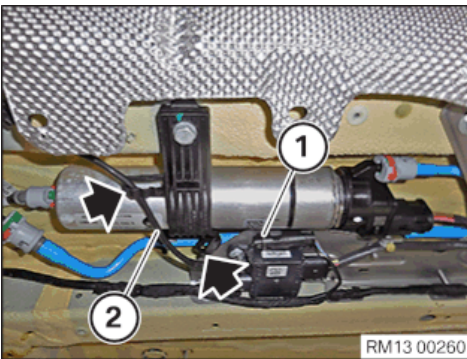

- Feed cable (2) from exhaust temperature sensor into the clamps (arrows) and install.
- Connect and lock the connector (1).  
 The connector (1) must engage audibly.

**45 – Install left output shaft**

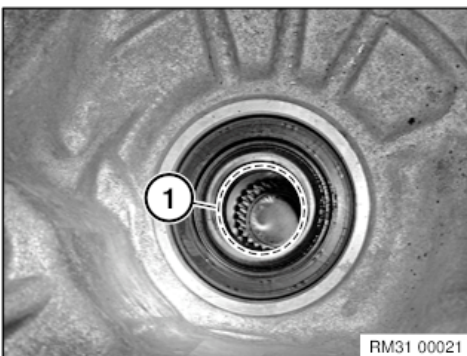

- **With automatic transmission only:**
  - Lever out O-ring (1).
  - Renew O-ring (1).
- Parts:** O-ring
- Insert new O-ring (1).

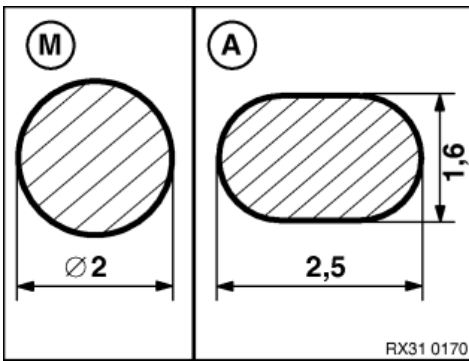

- Do not mix up circlips.
- Different types of output shafts fitted:
- M**: Manual transmission
  - A**: Automatic transmission

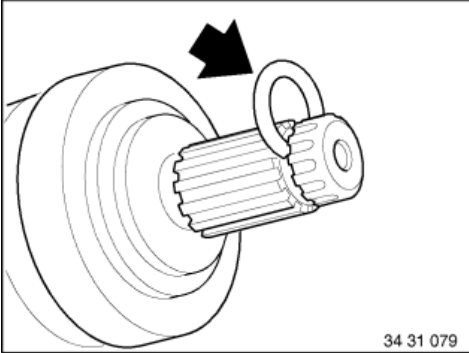

- Renew circlip (arrow).

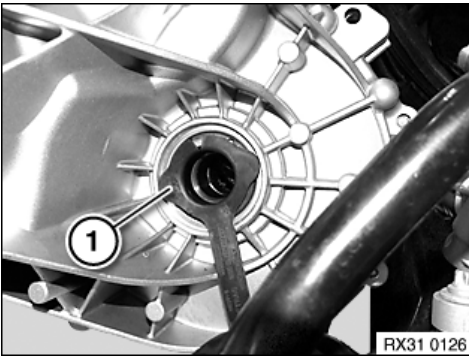

- Insert installation protection ring (1) into the radial shaft seal.
- Make sure the tool fits over the lip of the radial shaft seal so there is no damage to sealing ring when the output shaft is inserted.

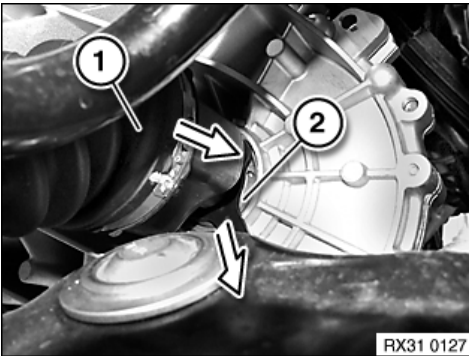

- Insert output shaft (1) into transmission.
- Note** Make sure the output shaft is joined in parallel to the axle and without being entangled.
- **Manual gearbox only:** Pull on the handle to remove the installation protection ring (2) and dispose of it.
  - Slide output shaft (1) into the transmission as far as the limit position. The output shaft (1) must engage audibly.
  - Check for secure seat by levering.

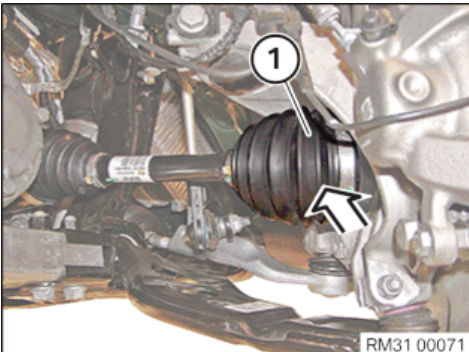

- Turn steering wheel to left.
- Insert the output shaft (1) into the swivel bearing from the front.

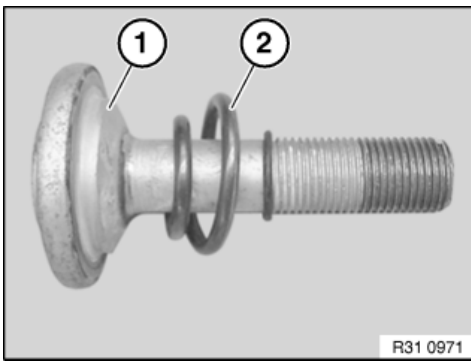

- Note installation position of compression spring (2).
- Keep the collar bolt (1) and the front gearing of the wheel bearing and the output shaft clean and free of grease.

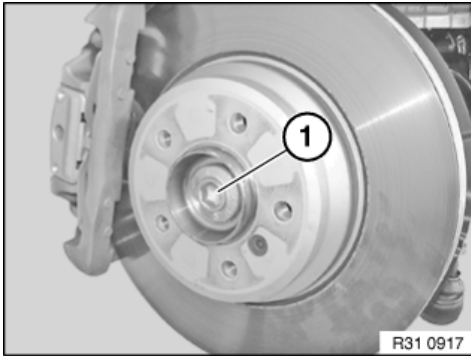

- Renew collar bolt (1) with compression spring.
- Parts:** Collar bolt with compression spring
- Hand-tighten the collar bolt (1) with the compression spring.

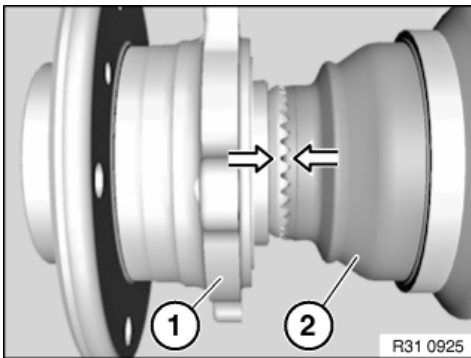

- Install the front gearing of the wheel bearing (1) and output shaft (2) in an interlocking position (tooth-in-tooth position).
- Check whether the front gearing is locked tooth in tooth by reciprocally rotating wheel hub and the output shaft.
- When positive locking is ensured: Tighten the collar bolt to tightening torque. For this purpose, press the brake pedal.

**Output shaft to wheel bearing**

M16	Replace the collar bolt.	Jointing torque	210 Nm
		Angle of rotation	90 °

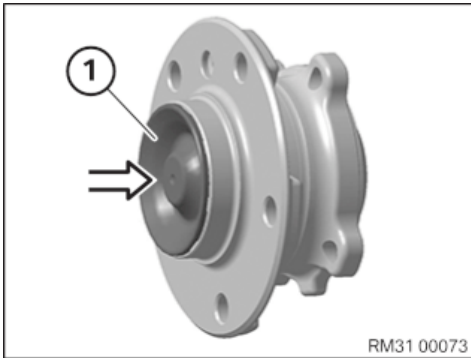

- If necessary, attach protective cap (1).

**46 – Install right output shaft**

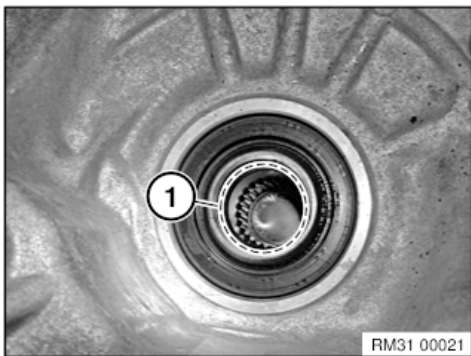

- **With automatic transmission only:**
  - Lever out O-ring (1).
  - Renew O-ring (1).
- Parts:** O-ring
- Insert new O-ring (1).

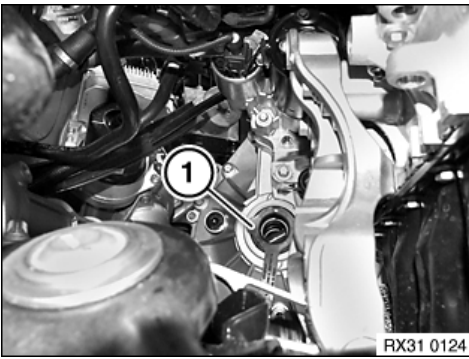

- Insert installation protection ring (1) into the radial shaft seal.
- Make sure the tool fits over the lip of the radial shaft seal so there is no damage to sealing ring when the output shaft is inserted.

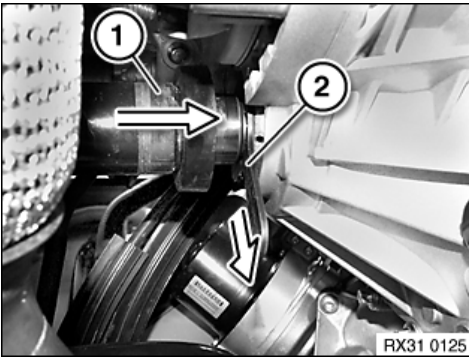

- Insert output shaft (1) into transmission.
- Note** Make sure the output shaft is joined in parallel to the axle and without being entangled.
- Pull on the handle to remove the installation protection ring (2) and dispose of it.
  - Slide output shaft (1) into the transmission as far as the limit position.
  - Check for secure seat by levering.

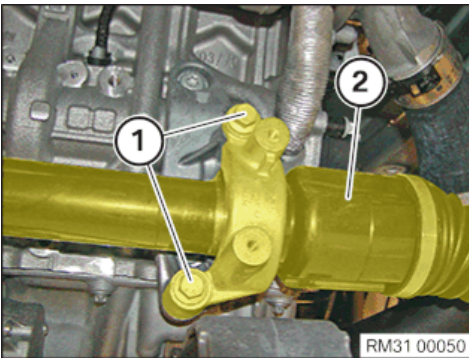

- Tighten the screws (1).

**Output shaft bearing to engine block**

M10	Tightening torque	38 Nm
-----	-------------------	-------

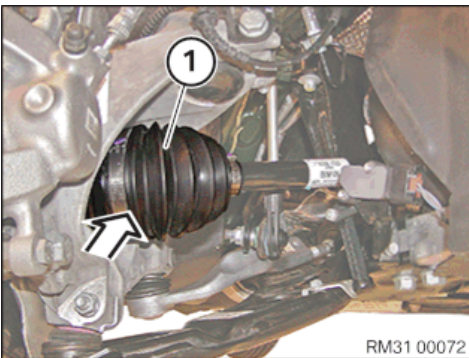

- Turn steering wheel to right.
- Insert the output shaft (1) into the swivel bearing from the front.

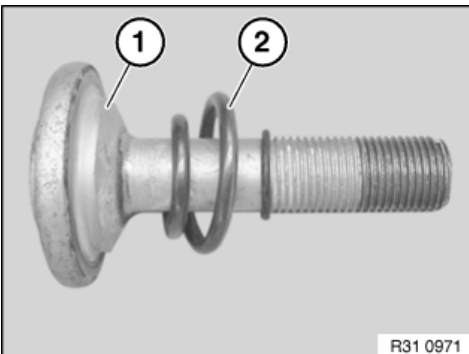

- Note installation position of compression spring (2).
- Keep the collar bolt (1) and the front gearing of the wheel bearing and the output shaft clean and free of grease.

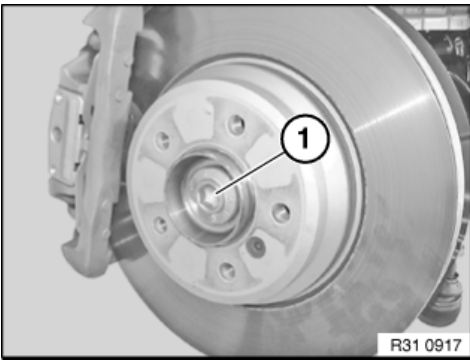

- Renew collar bolt (1) with compression spring.
- **Parts:** Collar bolt with compression spring
- Hand-tighten the collar bolt (1) with the compression spring.

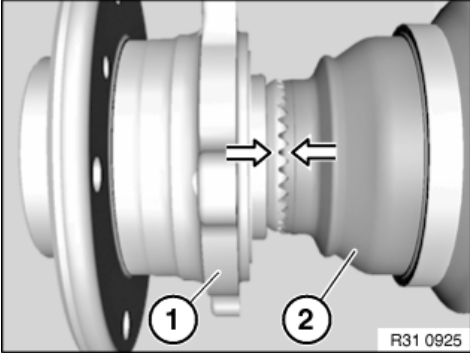

- Install the front gearing of the wheel bearing (1) and output shaft (2) in an interlocking position (tooth-in-tooth position).
- Check whether the front gearing is locked tooth in tooth by reciprocally rotating wheel hub and the output shaft.
- If positive locking is ensured: Tighten the collar bolt to tightening torque. For this purpose, press the brake pedal.

#### Output shaft to wheel bearing

M16	Replace the collar bolt.	Jointing torque	210 Nm
		Angle of rotation	90 °

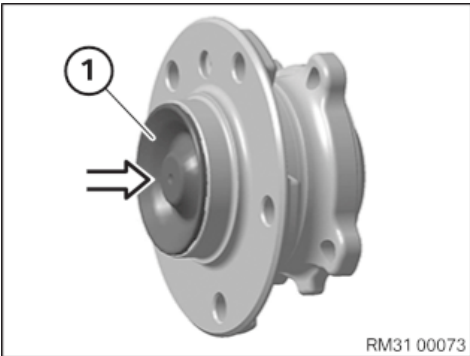

- If necessary, attach protective cap (1).

## 47 – Installing starter motor



**Improper routing of the positive battery cable.**

**Risk of short circuits!**

- Route the positive battery cable without abrasions and do not trap.

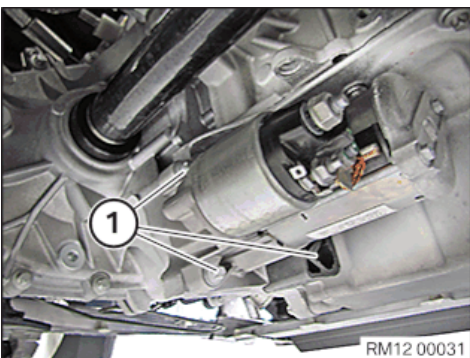

- Insert and install the starter motor .
- Tighten the screws (1).

#### Starter motor to transmission

M8x45		Tightening torque	19 Nm
-------	--	-------------------	-------

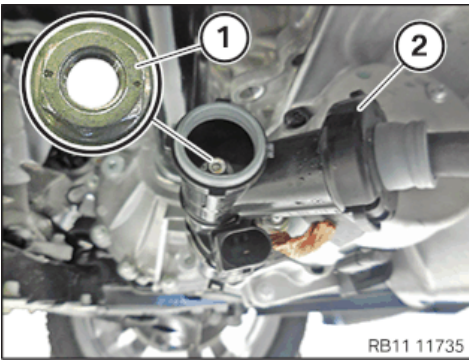

- Feed the positive battery cable (2) in on the starter and install.
- Tighten nut (1).

#### Battery positive lead to starter

M8

Tightening torque

13,5 Nm

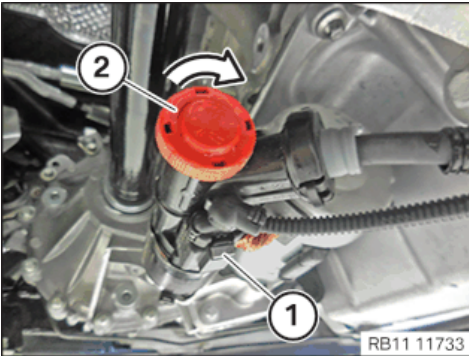

- Insert and install the new sealing cap (2).
- Secure the sealing cap (2) in the direction of the arrow.
- Connect and lock the connector (1).
- Make sure the connector (1) engages audibly.

#### 48 – Install front axle completely

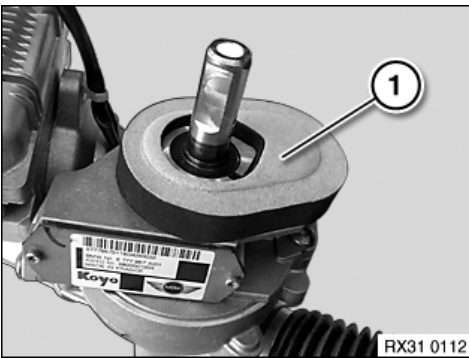

- Remove the seal (1).
  - Clean surface on steering gear.
  - Renew the gasket (1).
- Parts:** Gasket
- Position the seal (1) and glue it on.

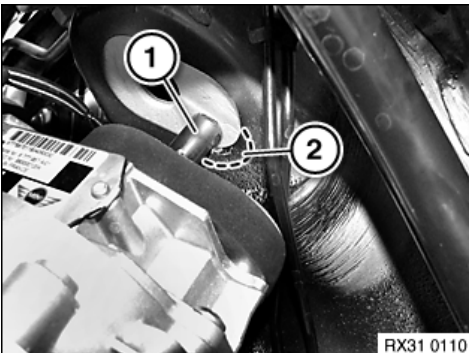

#### Collision of the torsion bar of the EPS with the bulkhead. Damage to the electromechanical steering gear (EPS)

- When lowering and lifting the front axle support, ensure that the torsion bar of the electromechanical steering gear (EPS) does not collide with the bulkhead.
- Make sure the torsion bar (1) of the electromechanical steering gear (EPS) in the area (2) does not collide with the bulkhead.

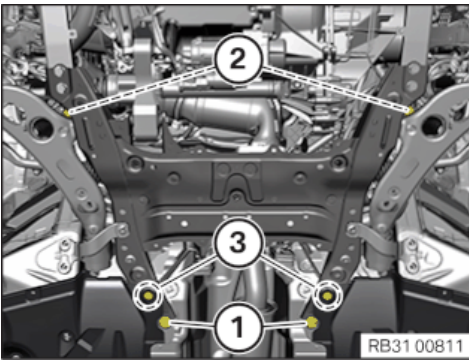

- Position the front axle completely with the universal jack.
- When lifting, feed the front axle support at the rear on the underbody panelling and the charge air cooler into the rubber mount of the charge air cooler.
- Lift the front axle completely with the universal jack.
- Renew screws (1) and (2).

**Parts:** Screws

- Tighten the screws (1).

**Rear end of front axle support to body**

M14 screw	Renew screw.	Tightening torque	175 Nm
-----------	--------------	-------------------	--------

- Tighten the screws (2).

**Front axle support, front to body**

M12 screw	Renew screw.	Tightening torque	108 Nm
-----------	--------------	-------------------	--------

- Tighten the screws (3).

**Underbody panelling, side**

Hexagon screw	Tightening torque	2,6 Nm
---------------	-------------------	--------

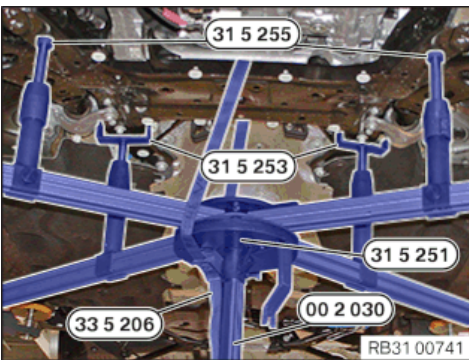

- Remove special tool from special tool .
- Lower the special tool **0 490 133 (00 2 030)** with the special tool and place it to the side.

**49 – Securing the mounted part on the front axle support**

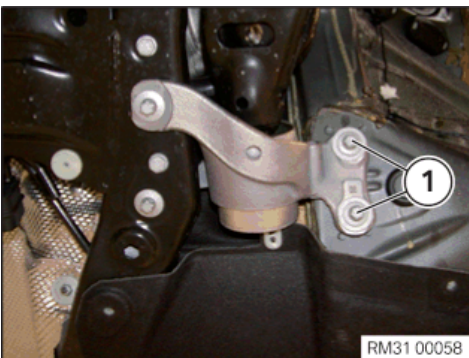

Perform the operations on the left and right side.

- Renew screws (1).

**Parts:** Screws

- Tighten the screws (1).

**Holder, wishbone rubber mount, to body**

M10 screw	Renew screw.	Jointing torque	56 Nm
		Angle of rotation	90 °

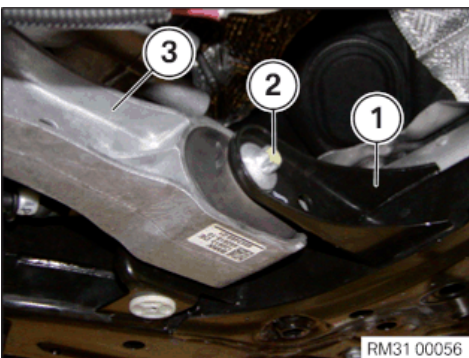

- Position the holder with rubber mount (3) on the front axle support (1).
- Tighten down screw (2).

**Holder with rubber mount to front axle support**

M12 screw			100 Nm
-----------	--	--	--------

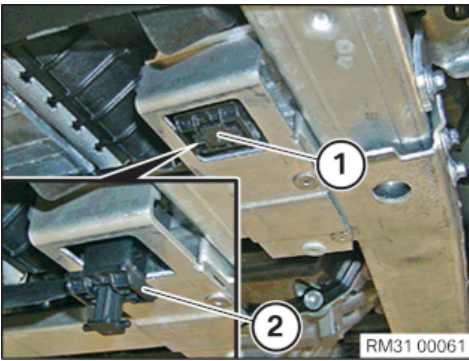

Perform the operations on the left and right side.

- Position lock (2).
- Lock safety catch (1) of the lock (2) from the holder for the charge air cooler.

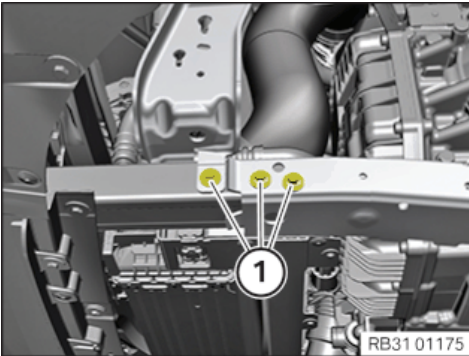

Perform the operations on the left and right side.

- Tighten the screws (1).

**Deformation element, bottom, to adapter plate, front axle carrier**

Screw	Tightening torque	11,8 Nm
-------	-------------------	---------

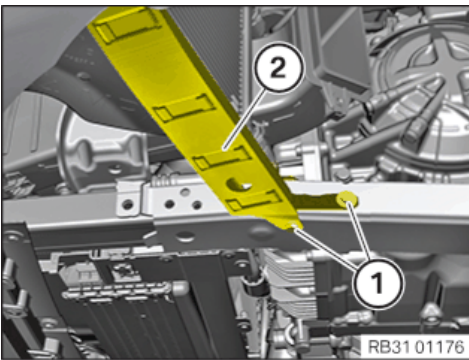

Perform the operations on the left and right side.



The following work step(s) is / are to be carried out if the specified component(s) is/are fitted.

- Feed in and position the holder (2) for the external radiator.
- Tighten the screws (1).

**Holder for external radiator on deformation element**

M6 screw	Tightening torque	8 Nm
----------	-------------------	------

**50 – Attaching connector at steering gear**

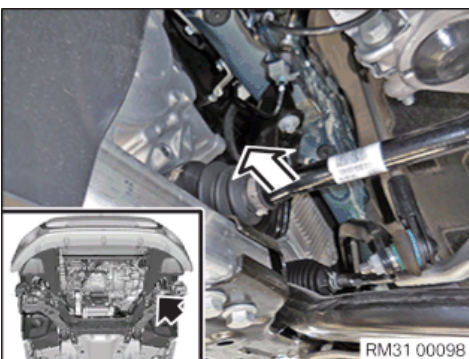

- To connect the connector (see the following step): Connect the connector with the right hand in the direction of arrow.  
The connectors can be accessed via the left output shaft (arrow).

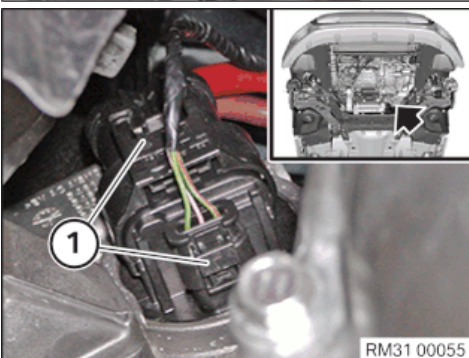

- Connect and lock connector (arrow) (1) with the steering gear.

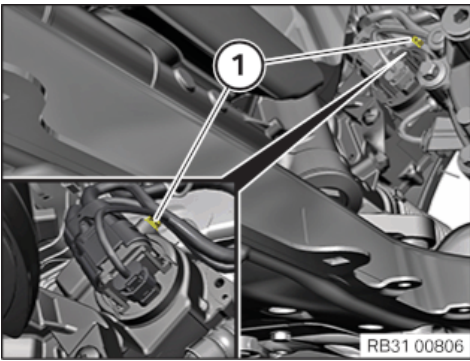

- Fasten the wiring harness (1) on the steering gear.

### 51 – Securing rubber mount on front axle support

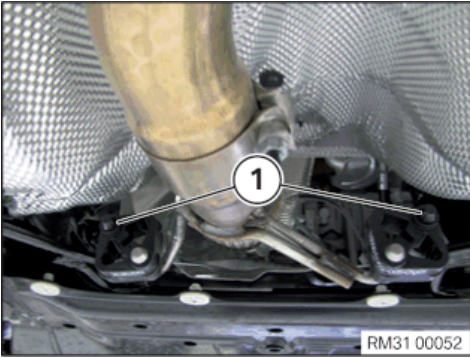

- Check the rubber mount (1) for damage and renew, if necessary.
- Spray rubber mount (1) with lubricant and slide onto holder on front axle support.

### 52 – Securing anti-roll bar on left and right on the anti-roll bar link



Perform the operations on the left and right side.

#### ► Fastening anti-roll bar on the anti-roll bar link

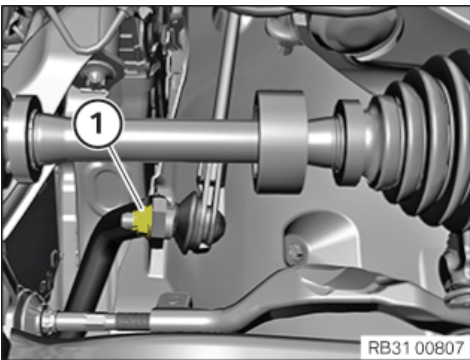

- Position the anti-roll bar link on the anti-roll bar .
- Renew nut (1).
- Tighten nut (1).

**Parts:** Nut

**Note** Use the Torx socket for counter support.

#### Anti-roll bar link to anti-roll bar/spring strut

M10	Renew nut.	Tightening torque	56 Nm

### 53 – With right installation: Securing the cable for the ride height sensor

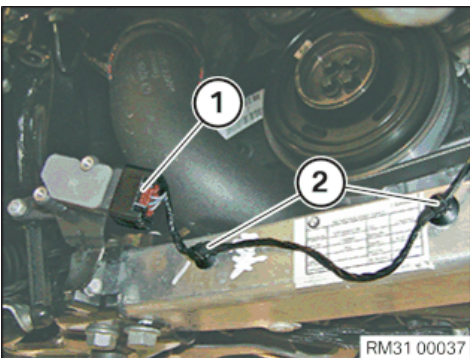

- Secure the cable clip (2) on the adapter of the deformation element.
- Connect connectors (1) and lock.

### 54 – Installing pressure pipe between throttle body and charge air cooler



### Damage to the exhaust turbocharger.

A leak at the pressure pipe can damage the exhaust turbocharger.

- Replace the gaskets and pressure pipe if necessary.

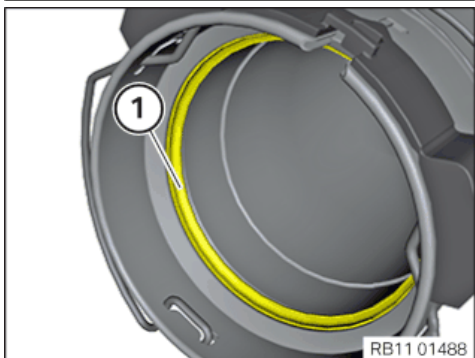
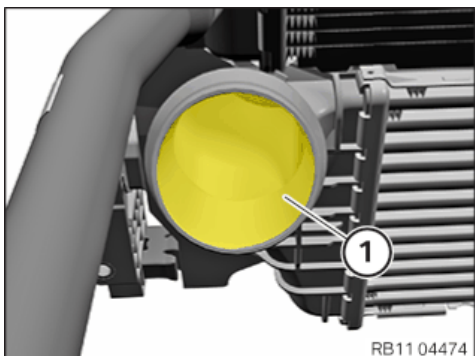

### Contaminant or foreign body.

Contamination can result in malfunctions, operating failure or leaks.

- Adhere to the utmost cleanliness.
- Protect components from contamination e.g. by covering.
- Close off line connections with seal plugs.

- Remove the auxiliary materials for locking the opening (1) of the charge air cooler.

- Check seal (1) for damage and renew seal (1) as needed.

**Parts:** Gasket

### ► Replacing damaged seal



Do not use pointed or sharp-edged tools for the installation and/or removal.

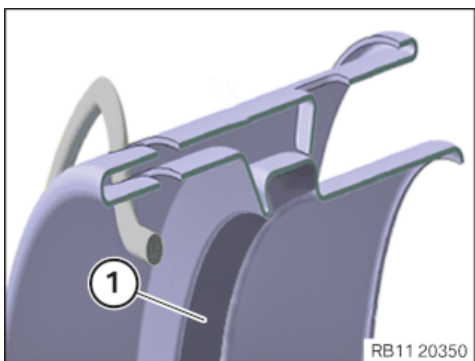

- Remove damaged seal.
- Clean gasket groove (1) with a dry towel.  
The gasket groove (1) must be clean.

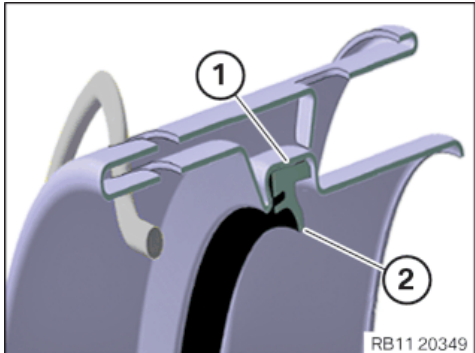

- Renew gasket.  
**Parts:** Gasket
- Install seal dry without lubricant or mounting agent.



Incorrect assembly is possible. Ensure correct installation position.

- Feed in and install the seal.
- Make sure the seal is correctly installed in the gasket groove (1).
- Make sure that the sealing lip (2) is directed inwards as shown.

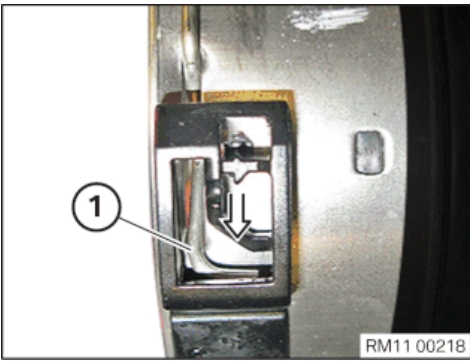

- Detach the locks (1) in the direction of the arrow from the brackets.

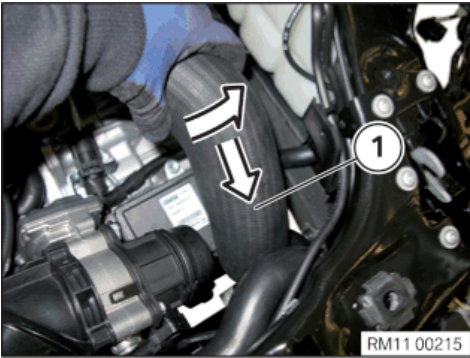

- Insert and install the pressure pipe (1) in the direction of the arrow.

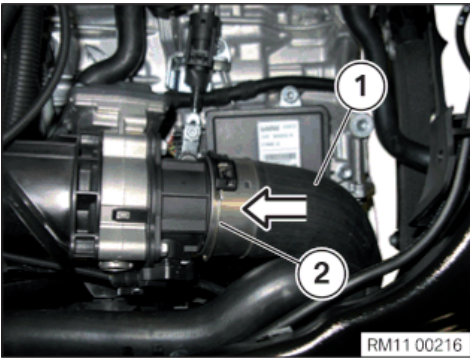

- Insert and install the pressure pipe (1) in the direction of the arrow.
- Ensure that the locks (1) engage audibly.

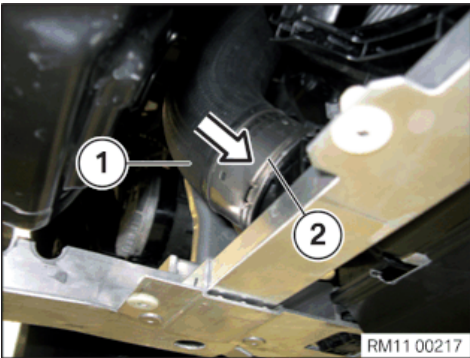

- Insert and install the pressure pipe (1) in the direction of the arrow.
- Ensure that the locks (2) engage audibly.

## 55 – Install right charge air duct



**Damage to the exhaust turbocharger.**

**A leak at the pressure pipe can damage the exhaust turbocharger.**

- Replace the gaskets and pressure pipe if necessary.

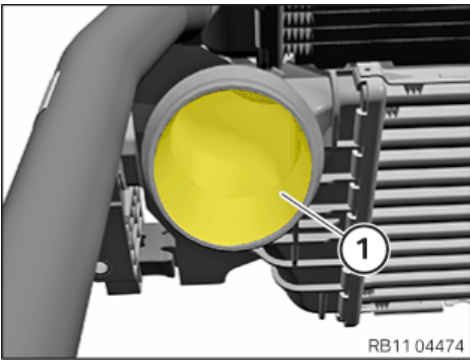

**Contaminant or foreign body.**

**Contamination can result in malfunctions, operating failure or leaks.**

- Adhere to the utmost cleanliness.
- Protect components from contamination e.g. by covering.
- Close off line connections with seal plugs.

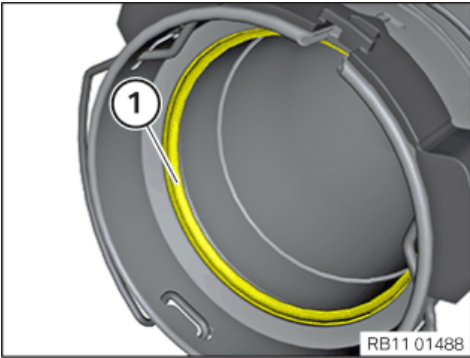

- Remove the auxiliary materials for locking the opening (1) of the charge air cooler.

- Check the sealing ring (1) for damage and renew the sealing ring (1) as needed.

**Parts:** Gasket

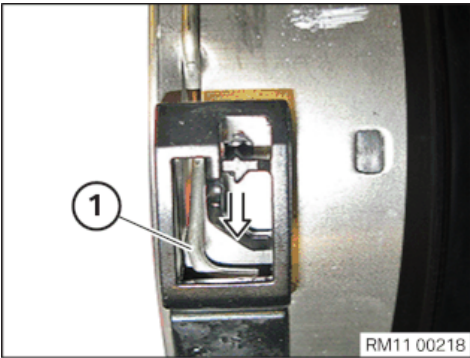

- Let the lock (1) engage at the holder (arrow).

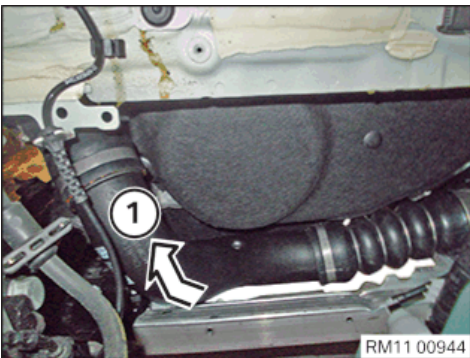

- Feed in charge air duct (1) to the side and upwards through the wheel arch between the side member and front axle support and install.

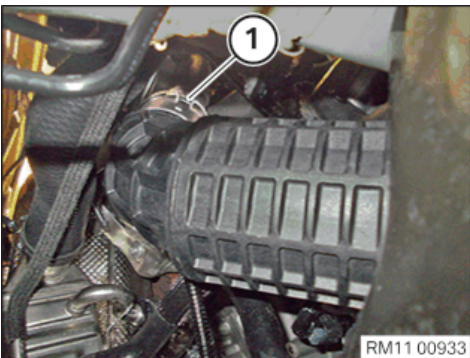

- Attach charge air duct on the exhaust turbocharger until locks (1) engage on both side.

The lock (1) must audibly engage.

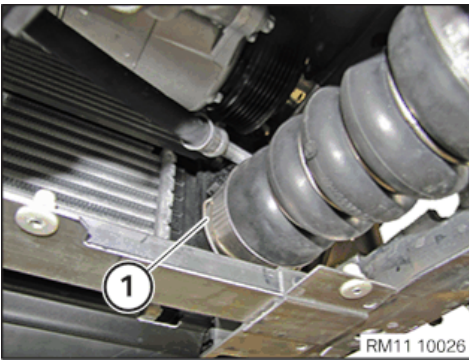

- Attach the pressure pipe to the charge air cooler until the lock (1) engages on both sides.  
The lock (1) must audibly engage.

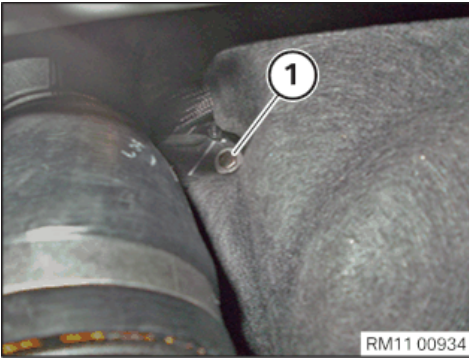

- Tighten screw (1) of the charge air duct on the crankcase.

**Charge air line to crankcase**

M6x25	Tightening torque	5 Nm
-------	-------------------	------

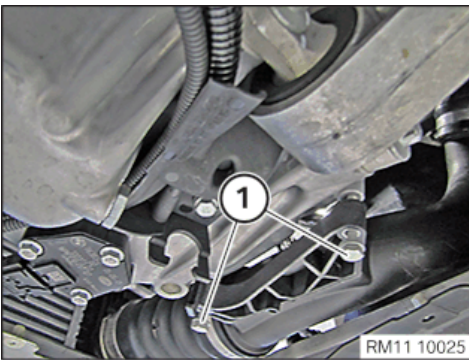

- Tighten charge air duct screws (1) on oil sump.

**Charge air duct to oil sump**

M6	Tightening torque	8 Nm
----	-------------------	------

**56 – Installing front left and right wheel arch cover**



Perform the operations on the left and right side.

► **Installing the front wheel arch cover**



To provide a better overview: Schematic diagram with partially hidden components.

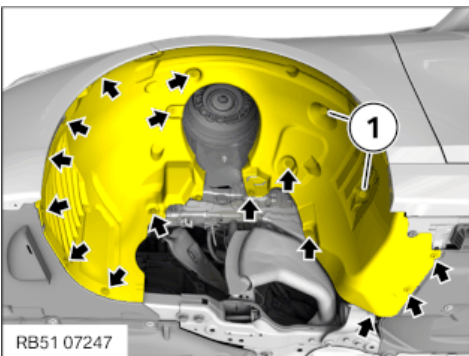

- Guide the front wheel arch cover in.
- Tighten screws (arrows).

**Wheel arch cover to body**

Hexagon screw	Tightening torque	2,6 Nm
---------------	-------------------	--------

- Tighten nuts (1).

**Wheel arch cover to body**

Plastic nut	Tightening torque	2,6 Nm
-------------	-------------------	--------

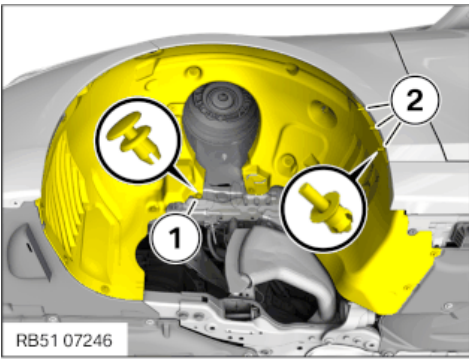

- Secure expanding rivet (2).
- Fasten expanding rivet (1).

► **If installed: Mount brake air duct**



To provide a better overview: Schematic diagram with partially hidden components.



- Tighten the screws (1).

**Wheel arch cover to brake air duct**

Hexagon screw	Tightening torque	2,6 Nm
---------------	-------------------	--------

**57 – Installing underbody panelling , right**

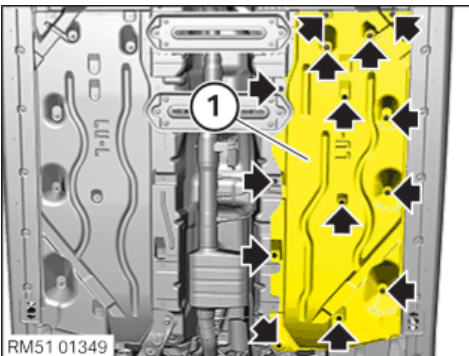

- Correctly position the underbody panelling (1).
- Tighten all bolts and nuts (arrows).

**Underbody panelling, side**

Hexagon screw	Tightening torque	2,6 Nm
---------------	-------------------	--------

**Underbody panelling, side**

Plastic nut	Tightening torque	2,6 Nm
-------------	-------------------	--------

**58 – Mounting the front left and right wheels**



Perform the operations on the left and right side.

► **Mounting the wheel**

- ▷ **Clean the contact surfaces between the brake disc and the wheel rim**

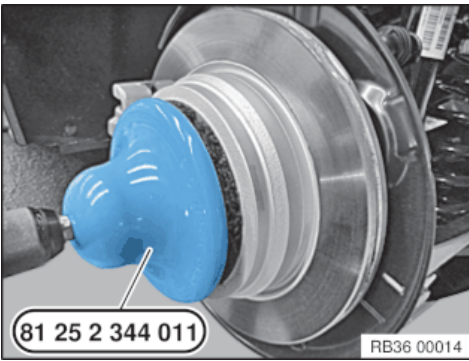

**i**

The contact surface between the brake disc and the wheel rim must be clean and free from oil and grease. There is otherwise a risk of the wheel becoming loose at a later time.

- Remove dirt, grease residues and corrosion from the contact surface with a drill and the special tool **2 344 011**.  
Do not operate special tool **2 344 011** with an impact screwdriver.
- Degrease the contact surfaces with the universal cleaner (see BMW Group Parts).
- If there are grease deposits in the area of the wheel bolt holes, remove and clean the brake disc.
- Remove dirt, grease residues and corrosion from the contact surface with a drill and the special tool **2 344 011**.  
Do not operate special tool **2 344 011** with an impact screwdriver.
- Degrease the contact surfaces with the universal cleaner (see BMW Group Parts).

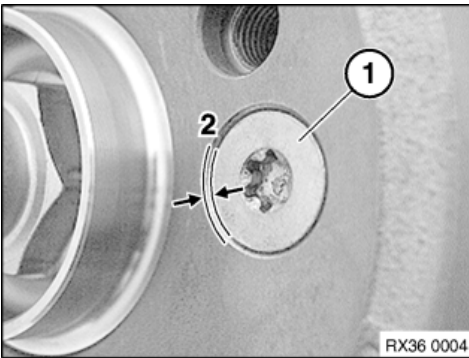
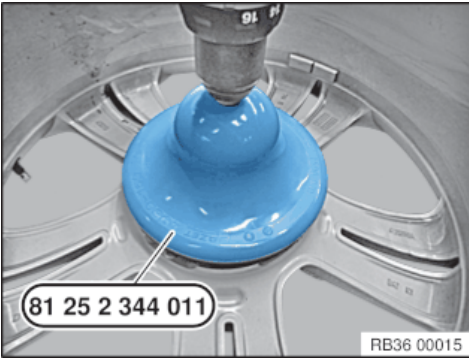

- Check that the mounting bolt (1) for the brake disc is securely seated.  
The mounting bolt (1) for the brake disc **may not** protrude on the contact surface (2) between the brake disc and the wheel rim.

#### Brake disc to front wheel hub

M8	Tightening torque	16 Nm
----	-------------------	-------

#### Brake disc to rear wheel hub

M8	Tightening torque	16 Nm
----	-------------------	-------

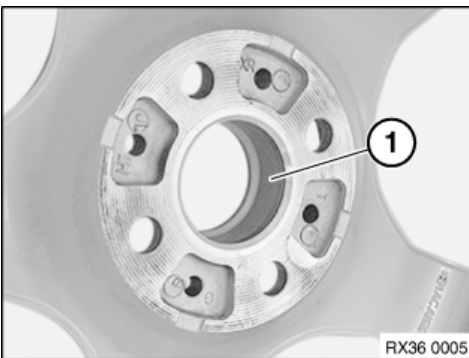

- Thinly grease the wheel centring (1) in the wheel rim.  
For the grease for the wheel centring (1) see further information.

◀

#### Check

- Check wheel bolts for wear.

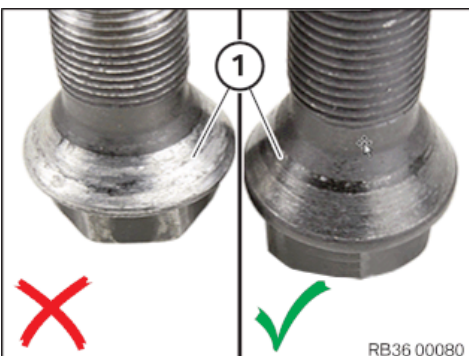

### Result

Spots (> 30%) of the bearing surface (1) of the taper on the screw head show silvery wear.

### Measure

- Replace wheel bolts.

**Parts:** Wheel bolts



Never use impact screwdrivers or electric screwdrivers to screw in and tighten the wheel bolts.

The wheel rim must rest uniformly against the brake disc.

In the case of non-original BMW wheel bolts/wheel rims, it may be necessary to retighten the wheel bolts on account of setting properties (refer to the documentation from the manufacturer).

Do not apply oil to new wheel bolts.

- Renew the corroded wheel bolts (arrows).

**Parts:** Wheel bolts

- Clean the wheel bolts (arrows).
- Check wheel bolts (arrows) and threads for damage, renew the wheel bolts if necessary.
- Join and tighten the wheel bolts (arrows).

### Wheel bolts

M 14/AF 17	Screw in wheel bolts and evenly tighten crosswise by hand in order to centre the wheel rim.	Tightening torque	140 Nm
	Tighten wheel bolts to the prescribed tightening torque with a calibrated torque wrench in a crosswise sequence.	Check	140 Nm
	Check all the wheel bolts in the same order or retighten to the prescribed tightening torque again.		

## 59 – Removing the mounting of the coolant radiator on the left and right

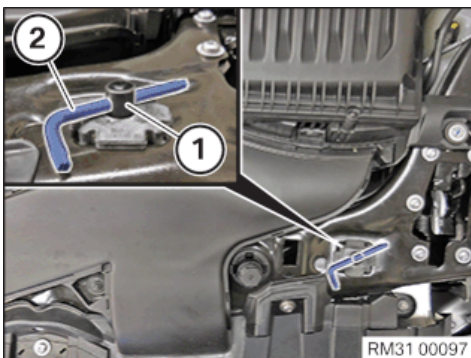

Perform the operations on the left and right side.

- Remove suitable tool (2) from the centering pin (1).

## 60 – Securing the steering shaft at the bottom on the steering gear

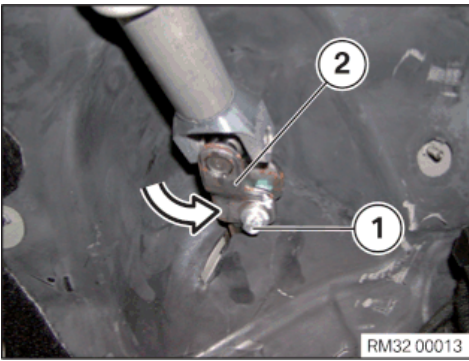

- Clean the screw thread in the universal joint (2) from the residues of screw locking agent.
  - Pivot the universal joint (2) in the direction of the arrow to the steering gear.
  - Renew the screw (1).
- Parts:** Screw
- Tighten down screw (1).

#### Lower steering shaft to steering gear

M10	Clean screw thread and remove remains of screw locking agent. Renew screw.	Tightening torque	28 Nm
-----	---	-------------------	-------

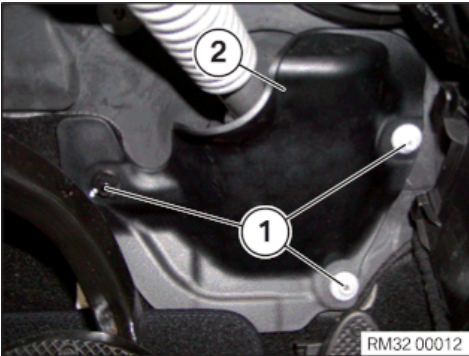

The following work step(s) is / are to be carried out if the specified component(s) is/are fitted.

- Position the cover (2) on the steering column.
- Tighten nuts (1).

#### Steering column cover to bulkhead

Plastic nut		Tightening torque	3 Nm
-------------	--	-------------------	------

### 61 – Installing rear bulkhead upper part

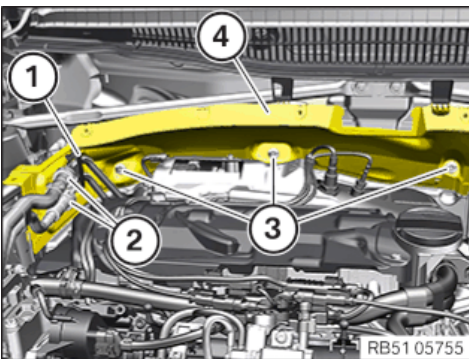

- Feed in and install the rear bulkhead upper part (4).
- Tighten the screws (3).

#### Rear bulkhead upper part to lower section of bulkhead

Oval-head screw		Tightening torque	5 Nm
-----------------	--	-------------------	------

- Feed the fuel line (2) into the holder (1) and install.
- Connect the holder (1) and lock.  
The holder (1) must engage audibly.

### 62 – Install the battery holder

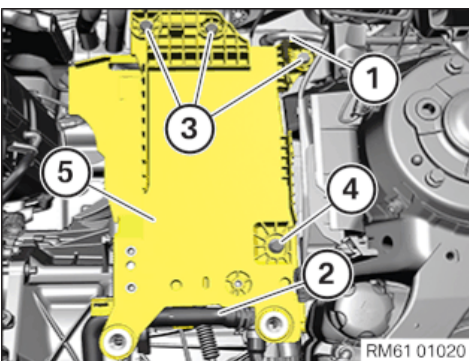

- Feed in and install the battery holder (5).
- Hand-tighten the bolt (4).
- Hand-tighten the bolts (3).
- Tighten down screw (4).

#### Battery holder to engine support

Hexagon screw M8x30		Tightening torque	19 Nm
---------------------	--	-------------------	-------

- Tighten down screws (3).

#### Battery holder to engine support

Hexagon screw M8x30		Tightening torque	19 Nm
---------------------	--	-------------------	-------

- Fasten the coolant line (2) on the battery holder (5).
- Fasten the cable clip (1) on the battery holder (5).

### 63 – Installing system battery

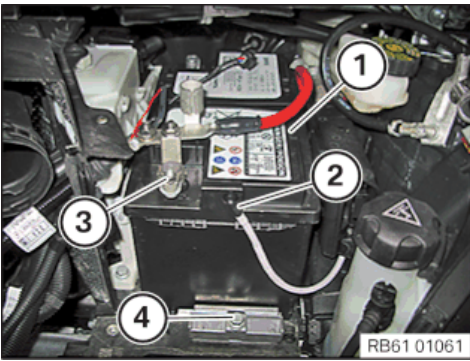

- Install system battery (1).
- Position the bracket and tighten with the screw (4) .

#### Battery terminal rail to battery tray

M8

19 Nm

- Position the vent hose (2) and clip it in.
- Position the positive battery terminal and tighten with the nut (3) .

#### Battery terminal with IBS positive battery terminal / negative battery terminal

NutM6

5 Nm

#### ► Check the vent holes of the battery



#### Gas emission.

#### Danger of injury! Danger of explosion!

- Assign the vent holes correctly.
- Route the vent hose correctly.



The battery has two vent holes, opposite:

One vent hole (1) must be closed correctly with a dummy plug.

The vent hose (3) must be correctly connected and routed at the other vent hole (2).

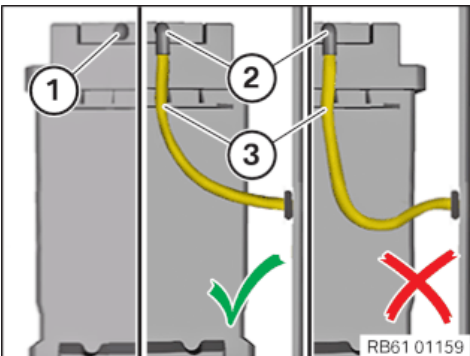

#### Check

- Check if the vent hole (1) is correctly closed with a dummy plug.

#### Result

No dummy plug.

#### Measure

- Close the vent hole (1) correctly with a dummy plug.

#### Check

- Check whether the vent hose (3) at the vent hole (2) has been connected correctly.

#### Result

The vent hose (3) is not correctly connected.

#### Measure

- Connect the vent hose (3) with the vent hole (2) correctly.

#### Check

- Check whether the vent hose (3) is routed with a downhill gradient to the outside (**no siphon formation**).

#### Result

The vent hose (3) is not routed correctly as shown at the right.

#### Measure

- Route the vent hose (3) correctly as shown in the centre.

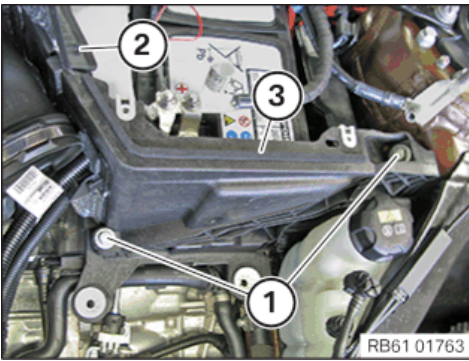

- Insert tension strut (3) and tighten with screws (1).

**Trailing link**

M8	Tightening torque	19 Nm
----	-------------------	-------

- Tighten down screw (2).

**Battery cover**

M8		2,8 Nm
----	--	--------

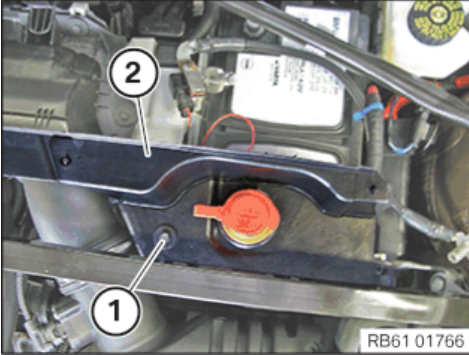

- Position the cover (2).
- Tighten down screw (1).

**Battery cover**

M8		2,8 Nm
----	--	--------

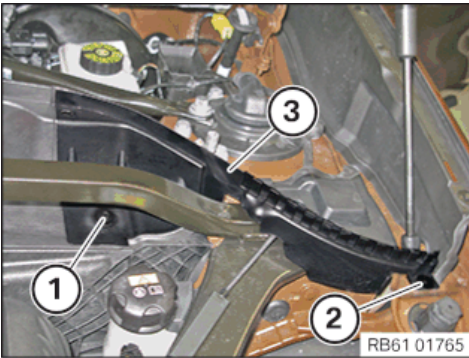

- Position the fixture for the gasket (3) and secure with the expanding rivet (2).
- Tighten down screw (1).

**Battery cover**

M8		2,8 Nm
----	--	--------

**64 – Install electronics box**

**Prerequisite**

Battery earth lead is disconnected.



**Improper routing of cables and wiring harnesses.**  
**Trapped, crushed or damaged cables may cause short circuits and malfunctions.**

- Route all cables without abrasions, do not trap and crush.

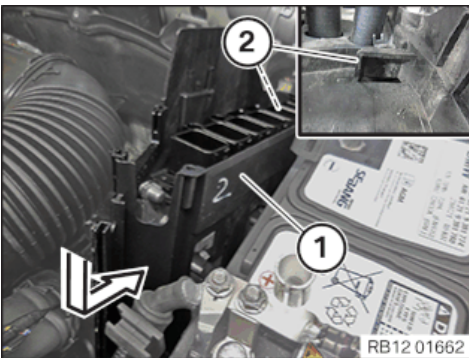

- Guide in and install the electronics box (1) into the guide (2) in direction of arrow.

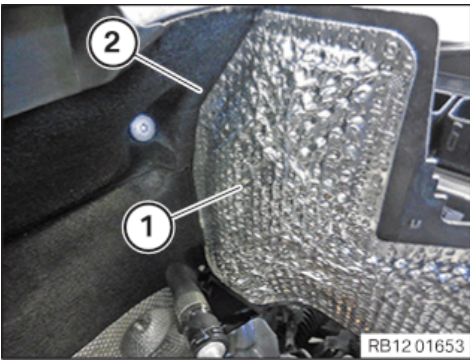

- Make sure that the electronics box (1) is positioned correctly on the bulkhead (2).

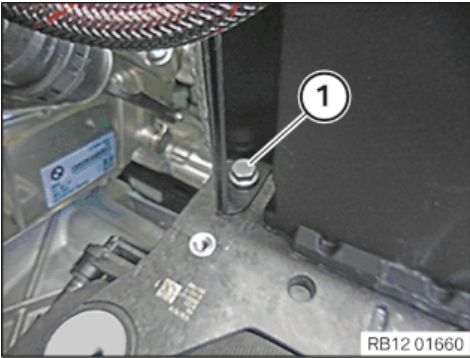

- Tighten down screw (1).

**Electronics box to battery tray**

M8X16	Tightening torque	15 Nm
-------	-------------------	-------

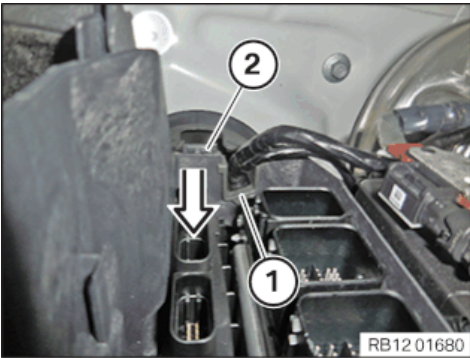

- Guide in and install the holder (1) in the electronics box (2) in direction of arrow. The holder (1) must engage audibly.

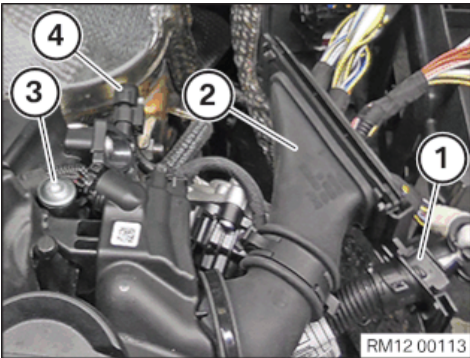

- Lay vehicle wiring harnesses (1) and (2) and mount on electronics box.
- Tighten down screw (3).

**Wiring harness to cylinder head cover**

TS5x20	Tightening torque	3,5 Nm
--------	-------------------	--------

- Connect the connector (4) to the differential pressure sensor and lock it audibly.

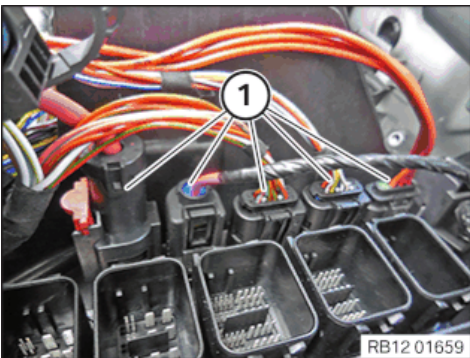

- Connect connectors (1) and lock. The connectors (1) must engage audibly.

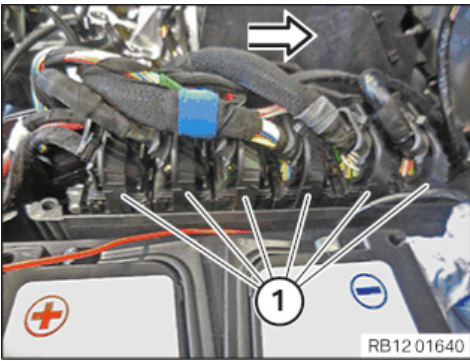

- Connect the connector (1) in the direction of arrow and lock it.  
The connectors (1) must engage audibly.

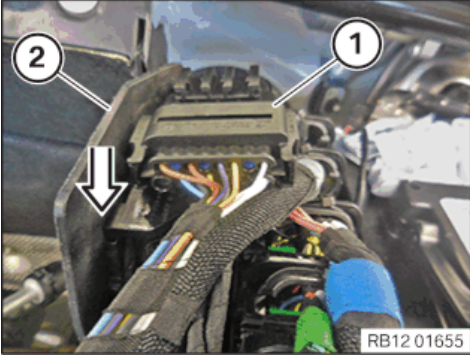

- Connect connectors (1) and lock.  
The connector (1) must engage audibly.
- Insert the connector (1) in the direction of arrow at the electronics box (2) and install.

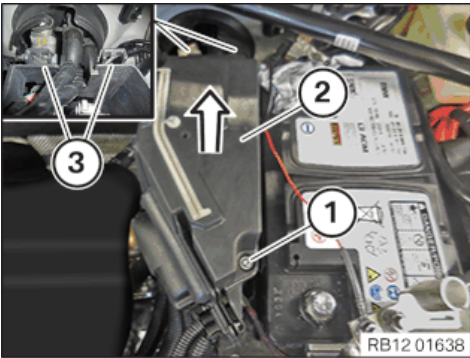

- Insert and install the cover (2) into the guides (3) in the direction of the arrow.  
The cover (2) must engage audibly in the guides (3).
- Tighten down screw (1).

**Cover to electronics box**

RF5x26.5	Tightening torque	2,5 Nm
----------	-------------------	--------

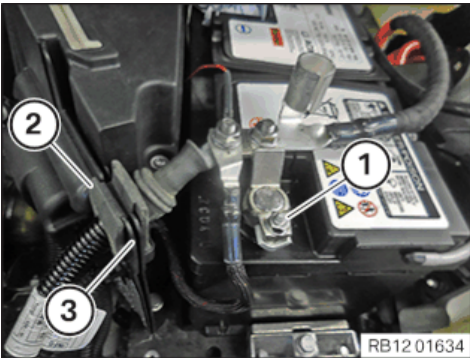

- Thread in positive battery cable (2) on holder (3) and install.
- Feed in and install positive battery terminal (1).
- Tighten positive battery terminal (1).

**Positive battery terminal to battery**

NutM6	Tightening torque	5 Nm
-------	-------------------	------

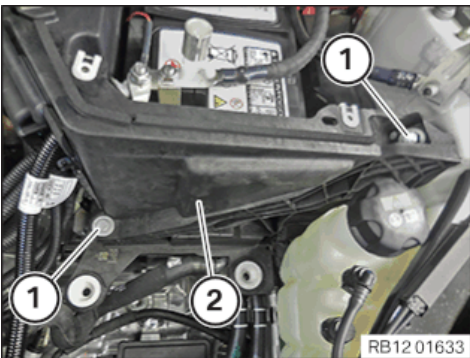

- Feed in and install tension strut (2).
- Tighten the screws (1).

**Tension strut to spring strut dome/battery tray**

M8	Tightening torque	19 Nm
----	-------------------	-------

**65 – Installing the upper bulkhead cover**

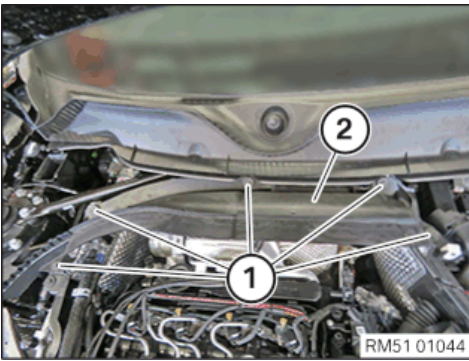

- Feed in and install cover (2) of the bulkhead at the top.
- Tighten the screws (1).

#### Bulkhead cover, top

Screw	Tightening torque	3 Nm
-------	-------------------	------

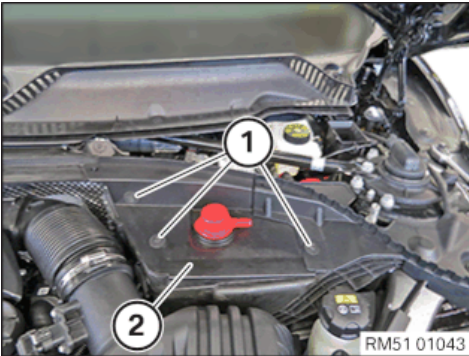

- Guide in and install cover (2).
- Tighten the screws (1).

#### Positive battery connection point cover to engine compartment partition wall

Tightening torque	3 Nm
-------------------	------

### 66 – Installing front cowl panel cover

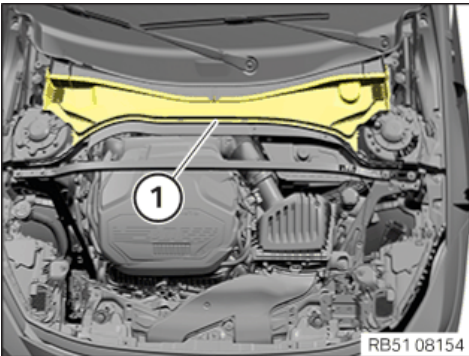

Schematic diagram is for example purposes. Some parts may differ in certain details.

- Guide the front cowl panel cover (1) towards the rear into the rear cowl panel cover and install.
- Ensure correct fit of the front cowl panel cover (1) relative to the rear cowl panel cover.

#### ► Attach cable (equipment specification with Electronic Damper Control)

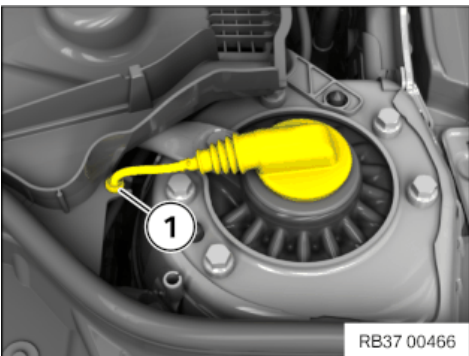

- Clip cable (1) into the front cowl panel cover.

### 67 – Install the seal for the bonnet



Schematic diagram is for example purposes. Some parts may differ in certain details.

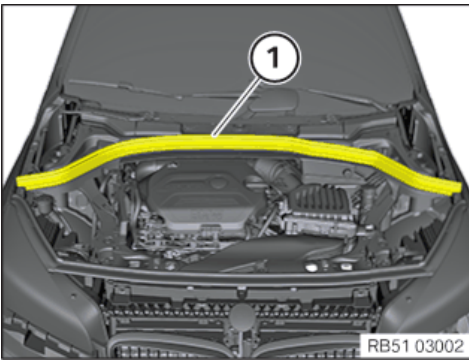

- Install the bonnet seal (1) and ensure correct fit.

### 68 – If installed: Install strut brace

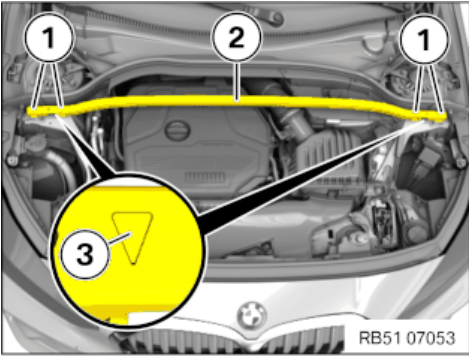

- Install the strut brace (2).  
When installing, make sure the arrow (3) points in the direction of travel.
- Renew screws (1).
- Tighten the screws (1).

**Parts:** Bolts

#### Suspension cross brace to body

M8x45 Hexagon screw	Renew screws.	Tightening torque	28 Nm
		Angle of rotation	180 °

### 69 – Remove cross connection

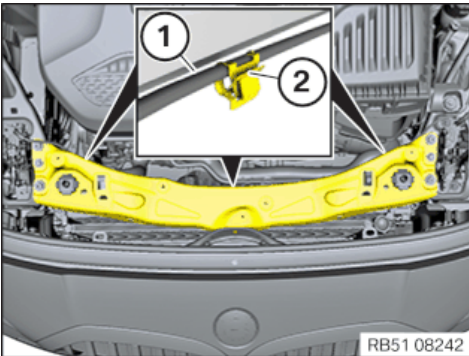

- Release the Bowden cable (1) from the cross connection using the clamps (2).

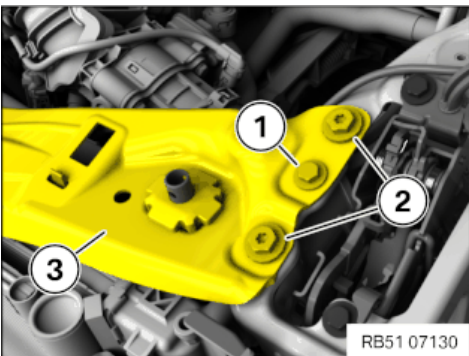

The operations shown only for one side must be carried out on both sides.

- Loosen screw (1).
- Loosen screws (2).
- Feed out and remove the cross connection (3) upwards.

### 70 – Connect the coolant line



Make sure that the connections are locked correctly. The locks must engage audibly.

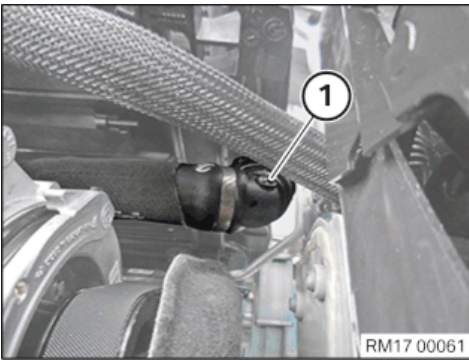

- Connect the right coolant line (1) to the radiator and lock audibly.

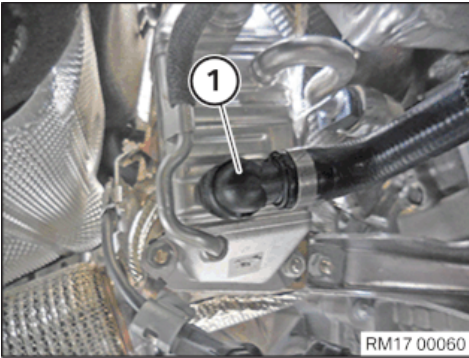

- Connect the coolant line (1) to the low pressure exhaust-gas recirculation cooler on the diesel particulate filter and lock audibly.

## 71 – Installing fan cowl with electric fan



Make sure that the connections are locked correctly. The locks must engage audibly.

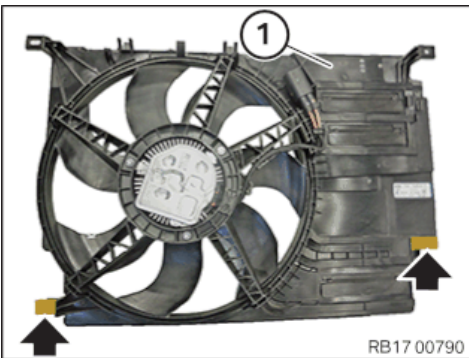

- Feed the guides (arrows) of the fan cowl (1) into the charge air cooler.

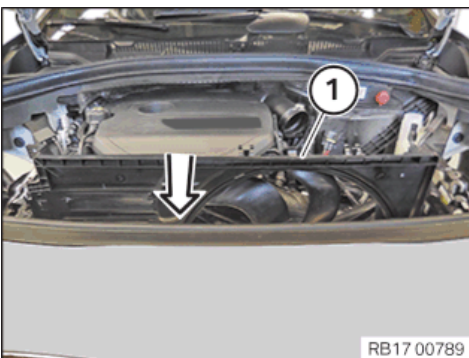

- Feed in and install the fan cowl (1) in the direction of the arrow.

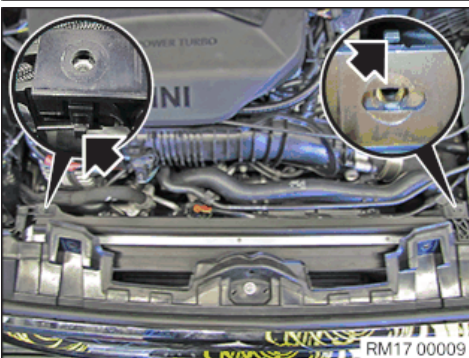

- Lock the left and right locks (arrows).

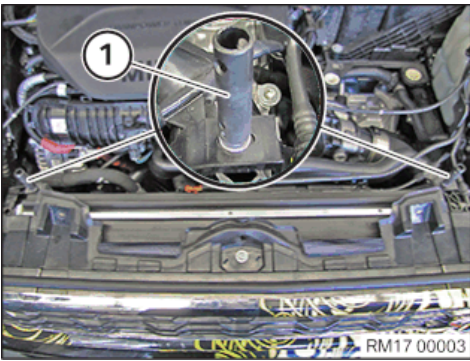

- Tighten the screws (1).

**Fan cowl on radiator**

M6X12	Tightening torque	6 Nm
-------	-------------------	------

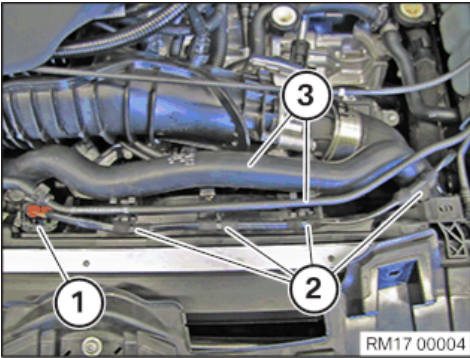

- Connect connectors (1) and lock. The connector (1) must engage audibly.
- Secure clamps (2).
- Thread in and install coolant line (3).

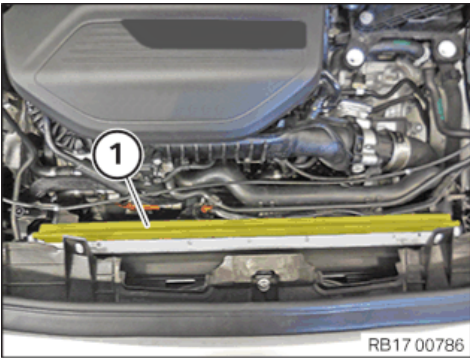

- Guide the sealing (1) on the radiator in and install it.

**72 – Install cross connection**

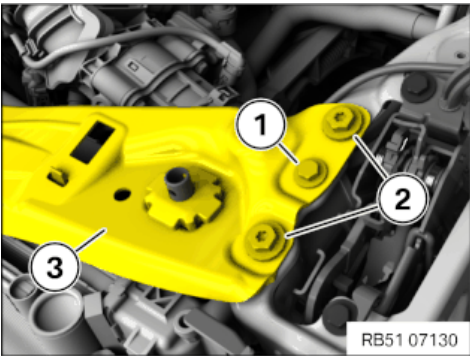

The operations shown only for one side must be carried out on both sides.

- Insert the cross connection (3) and position correctly.
- Tighten the screws (2).

**Cross connection on bonnet catch support**

Hexagon screw	Tightening torque	28 Nm
---------------	-------------------	-------

- Tighten down screw (1).

**Bonnet lock to bonnet lock support**

Hexagon screw M6x16	Tightening torque	11,8 Nm
------------------------	-------------------	---------

- Secure bowden cable (1) with the clamps (2) to the top connection.

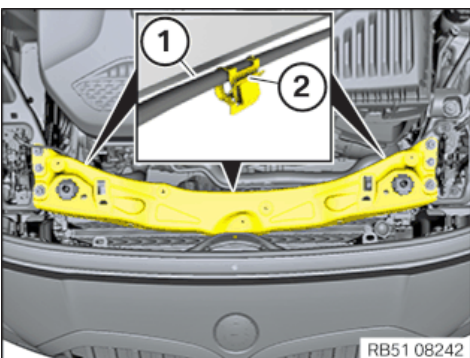

**73 – Partially securing bracing strut**

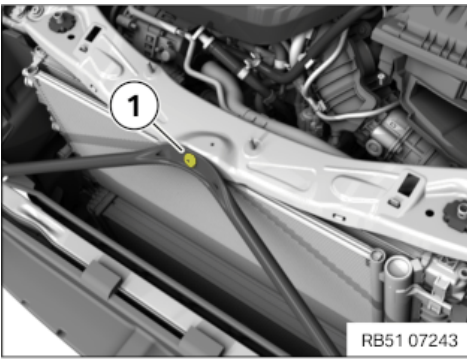

- Tighten screw (1) of the bracing strut.

**Bracing strut to top cross connection**

Oval-head screw	Tightening torque	25 Nm
-----------------	-------------------	-------

**74 – Installing the top cover**

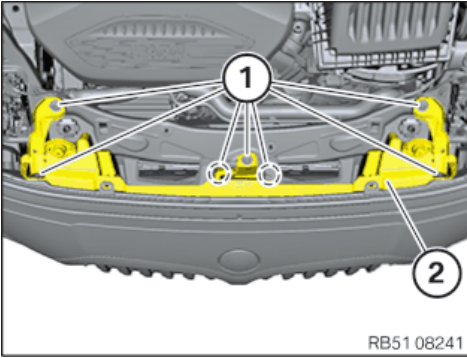

- Insert the top cover (2) and position it correctly.
  - Renew screws (1).
- Parts:** Bolts
- Tighten the screws (1).

**Cover, upper**

Oval-head screw	Renew screw	Tightening torque	8 Nm
-----------------	-------------	-------------------	------

**75 – Installing intake silencer housing**

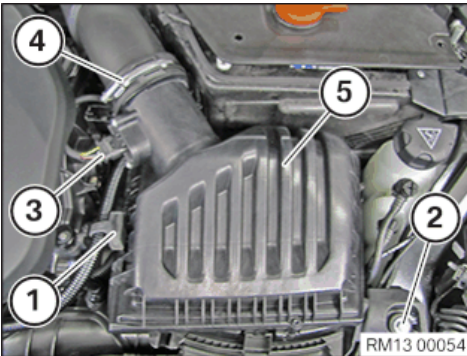

- Insert the intake silencer housing (5) into the rubber mounts and install it. Intake filter housing (5) must engage audibly.
- Tighten down screw (2).

**Intake silencer housing to lock bridge**

M6X30	Tightening torque	8 Nm
-------	-------------------	------

- Tighten clamp (4).

**Clean air pipe to intake silencer housing**

Clamp	Tightening torque	3 Nm
-------	-------------------	------

- Connect and lock the connector (3). The connector (3) must engage audibly.
- Insert and install the holder (1).

**76 – Install the intake neck for the intake filter housing**

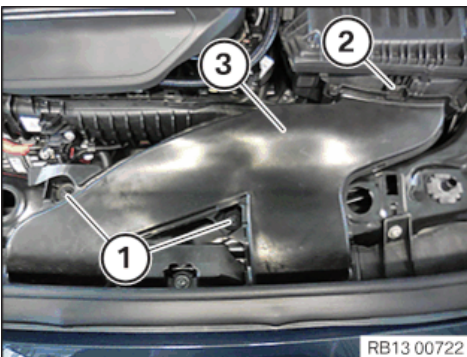

- Insert and install the intake neck (3). The lock (2) must audibly engage.
- Tighten nuts (1).

**Intake neck to cross connection**

M6	Tightening torque	8 Nm
----	-------------------	------

**77 – Install acoustic cover**



### Damage to the acoustic cover/design cover.

**Jerky movements during disassembly and excessive application of force during installation may result in breakage of the acoustic cover/design cover.**

- Disassemble or mount the acoustic cover/design cover carefully.
- Disassemble or mount snap-lock couplings of the ball pivots one after the other.
- Disassemble or mount acoustic cover/design cover only at temperatures >20 °C.
- Use only distilled water as an auxiliary material during installation, no lubricants.

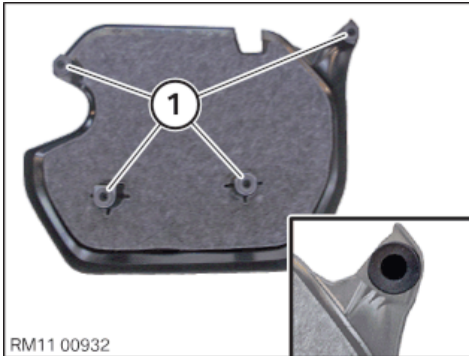

- Check for correct installation of all rubber mounts in the acoustic cover (1).



- Clip in the acoustic cover into the holders in the indicated areas.
- Make sure that the acoustic cover engages audibly.

### 78 – Removing the oil filler cap



- Open oil filler cap (1).

### 79 – Topping up the engine oil



#### Damage to the petrol particulate filter.

**Vehicles equipped with a petrol particulate filter must be operated using low-ash engine oil only.**

- Only use engine oils approved by BMW for the respective engine.
- For additional information see: Summary of technically suitable engine oils for BMW Group engines.



#### Engine damage caused by excessively filling the engine with engine oil.

**Filling an excessive quantity of engine oil may cause engine damage.**

- Observe the exact engine oil filling capacity.
- Allow engine oil to drip off when draining.

- Pour in engine oil.

### Engine oil B37C15U1

Capacity of engine oil

4,8 l

Engine oil: Technically suitable engine oils for BMW Group engines

## 80 – Installing the oil filler cap



- Close oil filler cap (1).

## 81 – Filling and bleed the high-temperature coolant circuit



It is **mandatory** to fill the cooling system before bleeding.  
Fill **both** the circuits for high and low-temperature coolant circuits.

- See additional information.

## 82 – Top up the oil level in the manual gearbox (GS6-58BG, GS6-59DG)



**Materials harmful to health.**

**Contact with fluids harmful to health!**

- Note and follow safety information on containers.
- Conduct all work in appropriate personal protective equipment only.

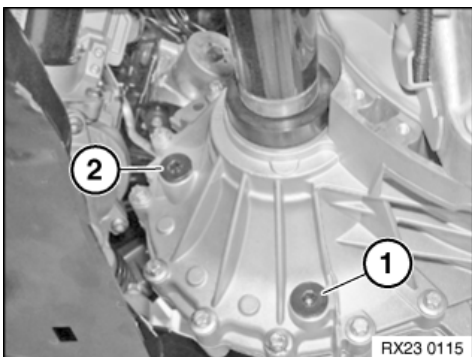

- Unscrew the oil filler plug (2) and fill the transmission, until the oil overflows.

### Transmission oil capacity

Transmission oil GS6-58/59BG/DG

1,9 l

Transmission oil: Technically suitable manual gearbox oil

- Allow surplus oil to drain off.
- Replace the oil filler plug (2).
- Tighten the oil filler plug (2).

**Parts:** Oil filler plug

### Oil drain plug / oil filler plug

Tightening torque

43 Nm

## 83 – If installed: Installing underbody protection at rear

- ▶ Installing underbody protection at rear

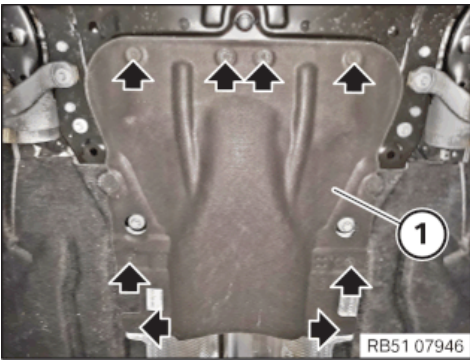

- Position rear underbody protection (1) .
- Tighten screws (arrows).

**Underbody protection to body**

Screw	Tightening torque	2.5 Nm
-------	-------------------	--------

**84 – Installing the front underbody protection**



Different variants may be installed depending on the vehicle equipment.

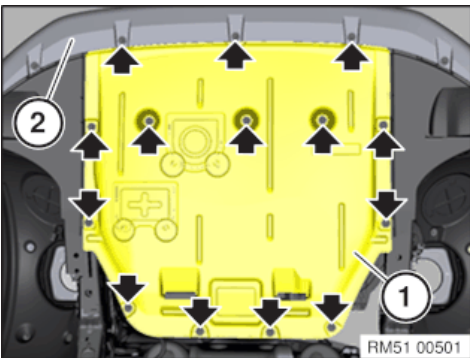

- **Version A:**  
Guide in the front underbody protection (1) at the bumper panel(2) and position.
- Tighten screws (arrows).

**Underbody protection to body**

Screw	Tightening torque	2.5 Nm
-------	-------------------	--------

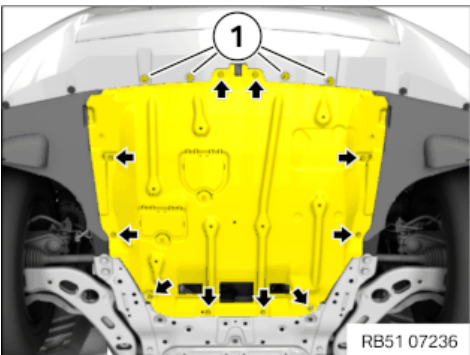

- **Version B (S8SDA):**  
Guide in the front underbody protection at the bumper panel and position it.
- Tighten screws (arrows).

**Front underbody protection on body/front axle support**

M6x20 screw	Tightening torque	8 Nm
-------------	-------------------	------

- Tighten the screws (1).

**Underbody protection to body**

Screw	Tightening torque	2.5 Nm
-------	-------------------	--------

► **Installing the front right cross-member**



Description is for left component only. Procedure on the right side is identical.

► **Installing the front cross-member**



The following work step(s) is / are to be carried out if the specified component(s) is/are fitted.

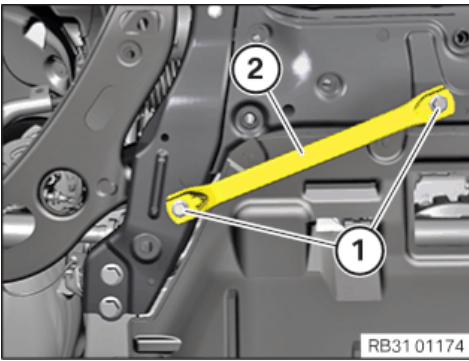

- Position the front cross-member (2).
  - Renew screws (1).
- Parts:** Screws
- Position screws (1).
  - Tighten the screws (1).

#### Cross-member on front axle support

M10x35	Renew screw.	Tightening torque	56 Nm
		Tightening torque	45 °

◀

## 85 – Check engine oil level

### Prerequisite

Vehicle is in a horizontal position.



Please comply with instructions in Owner's Handbook.

- Carry out an electronic oil measurement.
- Top up engine oil if necessary.

### ► Check engine oil level



Always check the engine oil level when the engine is at operating temperature (engine oil temperature > 70°C).

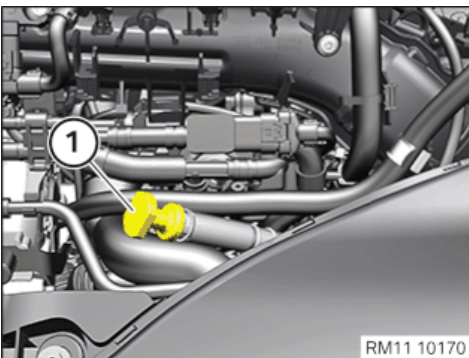

- Park vehicle on a horizontal surface.
- Stop the engine and wait for 5 minutes.
- Pull out the oil dipstick (1) and wipe off using a lint-free cloth.



Do not pull out or insert the oil dipstick into the guide tube too quickly or slowly.

- Push the oil dipstick (1) into the guide tube up to the limit position and pull it out again.



The engine oil level must be between the minimum mark and the maximum mark of the oil dipstick.

- Read the engine oil level on the oil dipstick.
- Top up engine oil if necessary.

#### Oil quantity between the minimum mark and the maximum mark of the oil dipstick

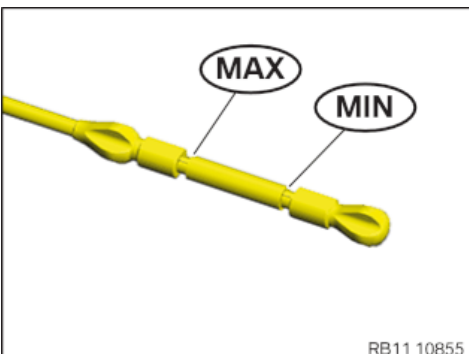

1,0 l

## 86 – Evacuate and fill air conditioning

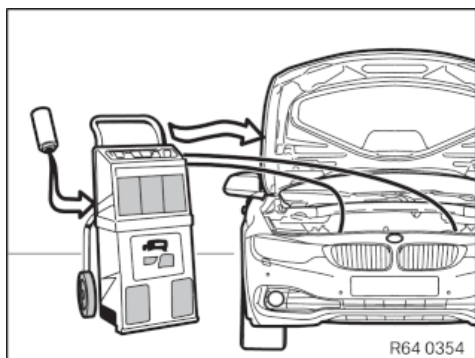

- See additional information.

## Additional Information

### Overview of Tightening Torques

<b>Oil drain plug on oil sump</b>			Used in step <a href="#">13</a>
M12x1.5	Renew the sealing ring.	Tightening torque	25 Nm
<b>Cross connection on bonnet catch support</b>			Used in step <a href="#">15</a> <a href="#">72</a>
Hexagon screw		Tightening torque	28 Nm
<b>Bonnet lock to bonnet lock support</b>			Used in step <a href="#">15</a> <a href="#">72</a>
Hexagon screw M6x16		Tightening torque	11,8 Nm
<b>Transmission mounting</b>			Used in step <a href="#">42</a>
M10	Renew screws.	Jointing torque	40 Nm
		Angle of rotation	90 °
<b>Right engine mount to cylinder head</b>			Used in step <a href="#">42</a>
M10	Renew screws.	Jointing torque	40 Nm
		Angle of rotation	90 °
<b>Refrigerant line on air conditioning compressor</b>			Used in step <a href="#">42</a>
M8		Tightening torque	19 Nm
<b>Clutch slave cylinder to transmission housing</b>			Used in step <a href="#">42</a>
M8		Tightening torque	19 Nm
<b>V-clip to catalytic converter</b>			Used in step <a href="#">42</a>
V-band clamp	Renew V-band clamp.	Tightening torque	25 Nm
<b>Standard screw connection M8</b>			Used in step <a href="#">42</a>
M8		Tightening torque	19 Nm
<b>Positive battery cable to positive battery terminal</b>			Used in step <a href="#">42</a>
M8		Tightening torque	15 Nm
<b>SCR metering module V-clip to exhaust system</b>			Used in step <a href="#">43</a>
V-band clamp	Renew V-band clamp.	Tightening torque	8 Nm
<b>Exhaust-gas temperature sensor to exhaust system</b>			Used in step <a href="#">44</a>
Exhaust-gas temperature sensor		Tightening torque	28 Nm
<b>Output shaft to wheel bearing</b>			Used in step <a href="#">45</a> <a href="#">46</a>
M16	Replace the collar bolt.	Jointing torque	210 Nm
		Angle of rotation	90 °

<b>Output shaft bearing to engine block</b>			Used in step <a href="#">46</a>
M10		Tightening torque	38 Nm
<b>Starter motor to transmission</b>			Used in step <a href="#">47</a>
M8x45		Tightening torque	19 Nm
<b>Battery positive lead to starter</b>			Used in step <a href="#">47</a>
M8		Tightening torque	13,5 Nm
<b>Rear end of front axle support to body</b>			Used in step <a href="#">48</a>
M14 screw	Renew screw.	Tightening torque	175 Nm
<b>Front axle support, front to body</b>			Used in step <a href="#">48</a>
M12 screw	Renew screw.	Tightening torque	108 Nm
<b>Underbody panelling, side</b>			Used in step <a href="#">48</a> <a href="#">57</a>
Hexagon screw		Tightening torque	2,6 Nm
<b>Holder, wishbone rubber mount, to body</b>			Used in step <a href="#">49</a>
M10 screw	Renew screw.	Jointing torque	56 Nm
		Angle of rotation	90 °
<b>Holder with rubber mount to front axle support</b>			Used in step <a href="#">49</a>
M12 screw			100 Nm
<b>Deformation element, bottom, to adapter plate, front axle carrier</b>			Used in step <a href="#">49</a>
Screw		Tightening torque	11,8 Nm
<b>Holder for external radiator on deformation element</b>			Used in step <a href="#">49</a>
M6 screw		Tightening torque	8 Nm
<b>Anti-roll bar link to anti-roll bar/spring strut</b>			Used in step <a href="#">52</a>
M10	Renew nut.	Tightening torque	56 Nm
<b>Charge air line to crankcase</b>			Used in step <a href="#">55</a>
M6x25		Tightening torque	5 Nm
<b>Charge air duct to oil sump</b>			Used in step <a href="#">55</a>
M6		Tightening torque	8 Nm
<b>Wheel arch cover to body</b>			Used in step <a href="#">56</a>
Hexagon screw		Tightening torque	2,6 Nm
<b>Wheel arch cover to body</b>			Used in step <a href="#">56</a>
Plastic nut		Tightening torque	2,6 Nm
<b>Wheel arch cover to brake air duct</b>			Used in step <a href="#">56</a>
Hexagon screw		Tightening torque	2,6 Nm
<b>Underbody panelling, side</b>			Used in step <a href="#">57</a>
Plastic nut		Tightening torque	2,6 Nm
<b>Brake disc to front wheel hub</b>			Used in step <a href="#">58</a>
M8		Tightening torque	16 Nm
<b>Brake disc to rear wheel hub</b>			Used in step <a href="#">58</a>
M8		Tightening torque	16 Nm

<b>Wheel bolts</b>			Used in step <a href="#">58</a>
M 14/AF 17	Screw in wheel bolts and evenly tighten crosswise by hand in order to centre the wheel rim.	Tightening torque	140 Nm
	Tighten wheel bolts to the prescribed tightening torque with a calibrated torque wrench in a crosswise sequence.	Check	140 Nm
	Check all the wheel bolts in the same order or retighten to the prescribed tightening torque again.		
<b>Lower steering shaft to steering gear</b>			Used in step <a href="#">60</a>
M10	Clean screw thread and remove remains of screw locking agent. Renew screw.	Tightening torque	28 Nm
<b>Steering column cover to bulkhead</b>			Used in step <a href="#">60</a>
Plastic nut		Tightening torque	3 Nm
<b>Rear bulkhead upper part to lower section of bulkhead</b>			Used in step <a href="#">61</a>
Oval-head screw		Tightening torque	5 Nm
<b>Battery holder to engine support</b>			Used in step <a href="#">62</a>
Hexagon screw M8x30		Tightening torque	19 Nm
<b>Battery terminal rail to battery tray</b>			Used in step <a href="#">63</a>
M8			19 Nm
<b>Battery terminal with IBS positive battery terminal / negative battery terminal</b>			Used in step <a href="#">63</a>
NutM6			5 Nm
<b>Trailing link</b>			Used in step <a href="#">63</a>
M8		Tightening torque	19 Nm
<b>Battery cover</b>			Used in step <a href="#">63</a>
M8			2,8 Nm
<b>Electronics box to battery tray</b>			Used in step <a href="#">64</a>
M8X16		Tightening torque	15 Nm
<b>Wiring harness to cylinder head cover</b>			Used in step <a href="#">64</a>
TS5x20		Tightening torque	3,5 Nm
<b>Cover to electronics box</b>			Used in step <a href="#">64</a>
RF5x26.5		Tightening torque	2,5 Nm
<b>Positive battery terminal to battery</b>			Used in step <a href="#">64</a>
NutM6		Tightening torque	5 Nm
<b>Tension strut to spring strut dome/battery tray</b>			Used in step <a href="#">64</a>
M8		Tightening torque	19 Nm
<b>Bulkhead cover, top</b>			Used in step <a href="#">65</a>
Screw		Tightening torque	3 Nm
<b>Positive battery connection point cover to engine compartment partition wall</b>			Used in step <a href="#">65</a>
		Tightening torque	3 Nm
<b>Suspension cross brace to body</b>			Used in step <a href="#">68</a>
M8x45 Hexagon screw	Renew screws.	Tightening torque	28 Nm
		Angle of rotation	180 °

<b>Fan cowl on radiator</b>			Used in step <a href="#">71</a>
M6X12		Tightening torque	6 Nm
<b>Bracing strut to top cross connection</b>			Used in step <a href="#">73</a>
Oval-head screw		Tightening torque	25 Nm
<b>Cover, upper</b>			Used in step <a href="#">74</a>
Oval-head screw	Renew screw	Tightening torque	8 Nm
<b>Intake silencer housing to lock bridge</b>			Used in step <a href="#">75</a>
M6X30		Tightening torque	8 Nm
<b>Clean air pipe to intake silencer housing</b>			Used in step <a href="#">75</a>
Clamp		Tightening torque	3 Nm
<b>Intake neck to cross connection</b>			Used in step <a href="#">76</a>
M6		Tightening torque	8 Nm
<b>Oil drain plug / oil filler plug</b>			Used in step <a href="#">82</a>
		Tightening torque	43 Nm
<b>Underbody protection to body</b>			Used in step <a href="#">83</a> <a href="#">84</a>
Screw		Tightening torque	2.5 Nm
<b>Front underbody protection on body/front axle support</b>			Used in step <a href="#">84</a>
M6x20 screw		Tightening torque	8 Nm
<b>Cross-member on front axle support</b>			Used in step <a href="#">84</a>
M10x35	Renew screw.	Tightening torque	56 Nm
		Tightening torque	45 °

## Overview of Special Tools

### 0 490 133 (00 2 030) Device

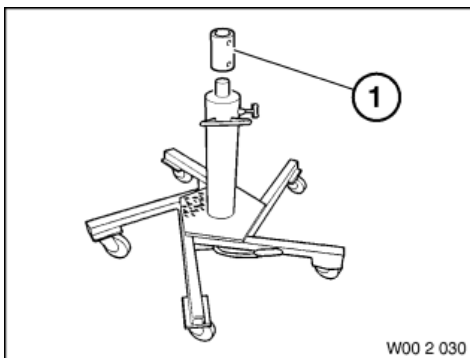

**Common** Used in step [35](#) [48](#)

Usage (universal hydraulic lifter base unit) Chassis and hydraulic lifter - For removing and installing rear axle supports and gearboxes. Also for soft top mounts. Is replaced by 81 22 2 219 012

Included in the tool or work

Storage location

Replaced by

In connection with

SI-Number 01 05 90 (207)

#### Consisting of

Pos	BMW Order number	Replaced by	Designation	In Connection with
1	<a href="#">0 490 134 (00 2 031)</a>		<b>Adapter</b> (adapter for gearbox holder) Model series: E30, E31, E32, E34, E36	

### 2 305 379 Accessories

**Common** Used in step [41](#)

Usage Holder set for MHT 1200 major assembly table lift and new generation (from 2020)

Included in the tool or

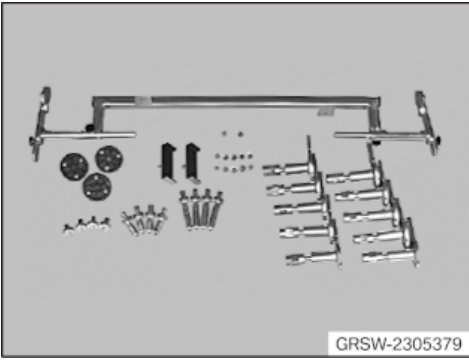

Included in the tool or work

Storage location Individual

Replaced by

In connection with Mobile major assembly table lift MHT 1200 81222184136

SI-Number 06 01 10 (649)

## 2 184 136 Mobile unit table lift

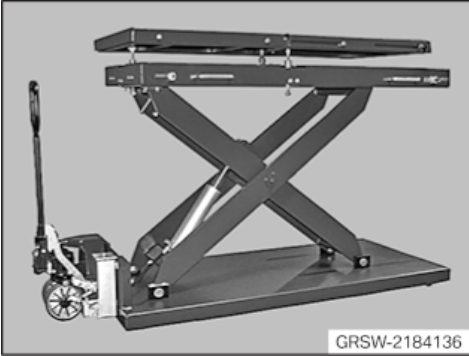

**Common**

Used in step [41](#)

Usage Table lift MHT 1200

Included in the tool or work

Storage location

Replaced by

In connection with

SI-Number 06 01 10 (649)

## 2 344 011 Tool



**Common**

Used in step [58](#)

Usage Tool (wheel hub grinder) for cleaning the connection of the wheel rim (wheel contact face) to the wheel hub.

Included in the tool or work

Storage location

Replaced by

In connection with

SI-Number 08 08 12 (872)

## Replacement tools:

### 0 495 221 (36 1 323) Wheel stud

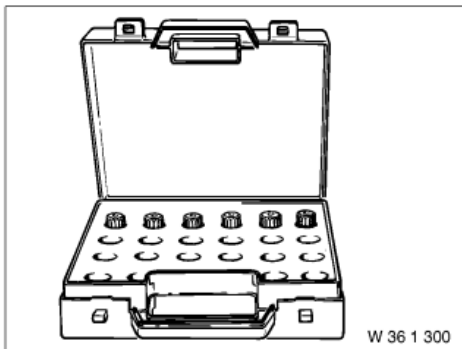

**Common**

Used in step [24](#)

Usage (Code 30) Code 39 available separately, (see EPC) under 36 13 1 181 259

Included in the tool or work 0 492 518

Storage location

Replaced by

In connection with

SI-Number

### 0 495 224 (36 1 326) Wheel stud

**Common**

Used in step [24](#)

Usage (Code 33) With centring bore available separately, (see EPC) under 36 13 6 765 546

Included in the tool or work 0 492 518

Storage location

Replaced by

In connection with



SI-Number

**0 495 225 (36 1 327) Wheel stud**

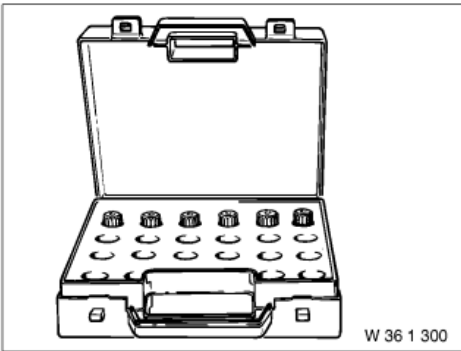

**Common**

Used in step [24](#)

Usage (Code 34) With centring bore available separately (see EPC) under 36 13 6 765 547

Included in the tool or work 0 492 518

Storage location

Replaced by

In connection with

SI-Number

**0 495 226 (36 1 328) Wheel stud**

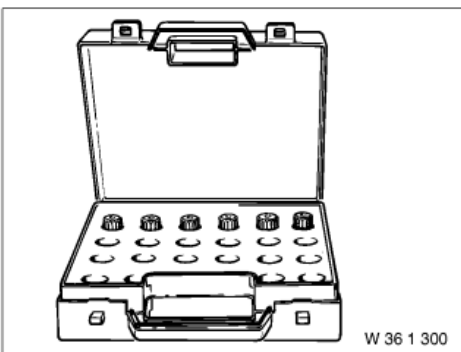

**Common**

Used in step [24](#)

Usage (Code 35) With centring bore available separately, (see EPC) under 36 13 6 762 340

Included in the tool or work 0 492 518

Storage location

Replaced by

In connection with

SI-Number

**0 495 227 (36 1 329) Wheel stud**

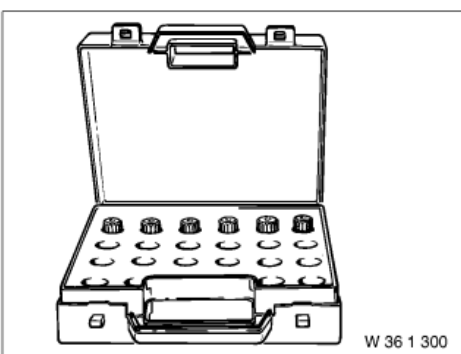

**Common**

Used in step [24](#)

Usage (Code 36) With centring bore available separately (see EPC) under 36 13 6 762 341

Included in the tool or work 0 492 518

Storage location

Replaced by

In connection with

SI-Number

**0 495 228 (36 1 331) Wheel stud**

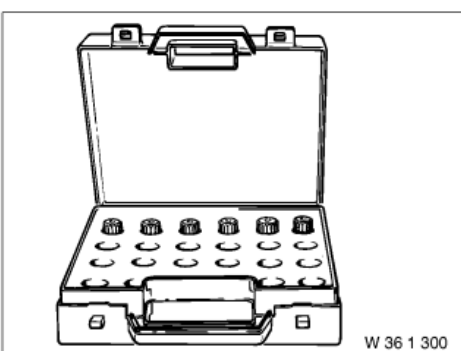

**Common**

Used in step [24](#)

Usage (Code 37) With centring bore available separately (see EPC) under 36 13 6 762 342

Included in the tool or work 0 492 518

Storage location

Replaced by

In connection with

SI-Number

### 0 495 229 (36 1 332) Wheel stud

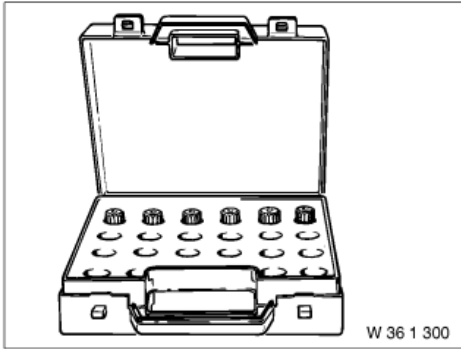

#### Common

Used in step [24](#)

Usage	(Code 38) With centring bore available separately (see EPC) under 36 13 6 762 343
Included in the tool or work	0 492 518
Storage location	
Replaced by	
In connection with	
SI-Number	

### 0 495 230 (36 1 333) Wheel stud

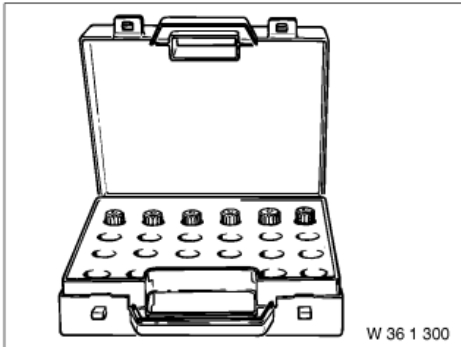

#### Common

Used in step [24](#)

Usage	(Code 40) With centring bore available separately (see EPC) under 36 13 6 762 344
Included in the tool or work	0 492 518
Storage location	
Replaced by	
In connection with	
SI-Number	

## Overview Technical Data

### Engine oil B37C15U1

Used in step [79](#)

Capacity of engine oil	4,8 l
Engine oil: Technically suitable engine oils for BMW Group engines	

### Transmission oil capacity

Used in step [82](#)

Transmission oil GS6-58/59BG/DG	1,9 l
Transmission oil: Technically suitable manual gearbox oil	

### Oil quantity between the minimum mark and the maximum mark of the oil dipstick

Used in step [85](#)

1,0 l

## Links

## 23 00 230 Remove and install manual transmission



**Motor vehicle may slip off the vehicle hoist where components are supported.**

**Danger! Life-threatening injuries!**

- Secure the vehicle hoist against lowering and lifting.



**Motor vehicle may slip off the vehicle hoist if the weight is distributed unevenly.**

**Danger! Life-threatening injuries!**

- Ensure there is a specific weight compensation on the motor vehicle.



**Vehicle may slip off the vehicle hoist if the vehicle hoist is handled incorrectly.**

**Danger! Life-threatening injuries!**

- Observe safety information on raising the vehicle using a vehicle hoist.
- For additional information see: 00 ... Raise the vehicle using a vehicle lift.



**Component with heavy weight.**

**Danger of injury!**

- Note component's centre of gravity.
- Support component using a jack.
- Secure component against falling off the jack.



**Materials harmful to health.**

**Contact with fluids harmful to health!**

- Note and follow safety information on containers.
- Conduct all work in appropriate personal protective equipment only.

### PRELIMINARY WORK

---

#### 1 – Removing the acoustic cover



**Hot surfaces.**

**Risk of burning!**

- Perform all work only on components that have cooled down.



**Damage to the acoustic cover/design cover.**  
**Jerky movements during disassembly and excessive application of force during installation may result in breakage of the acoustic cover/design cover.**

- Disassemble or mount the acoustic cover/design cover carefully.
- Disassemble or mount snap-lock couplings of the ball pivots one after the other.
- Disassemble or mount acoustic cover/design cover only at temperatures  $>20\text{ }^{\circ}\text{C}$ .
- Use only distilled water as an auxiliary material during installation, no lubricants.

- Unclip the acoustic cover from the marked areas towards the top.

## 2 – Disconnecting all battery earth leads



- See additional information.

## 3 – Remove the seal for the rear bonnet



Schematic diagram is for example purposes. Some parts may differ in certain details.

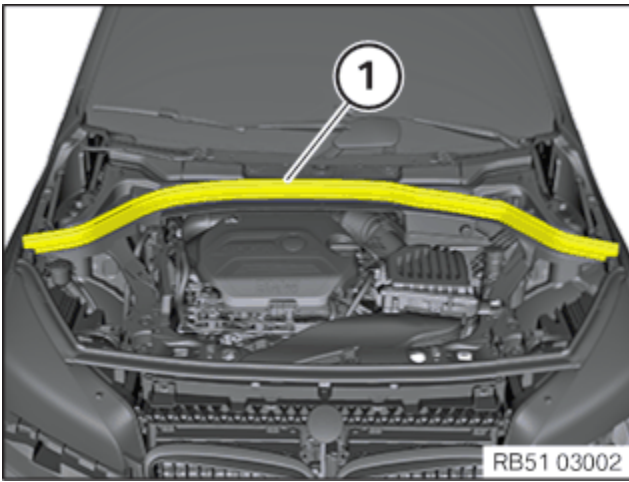

- Pull off the bonnet seal (1) towards the top and remove.

#### 4 – Removing the seal fixture for the bonnet

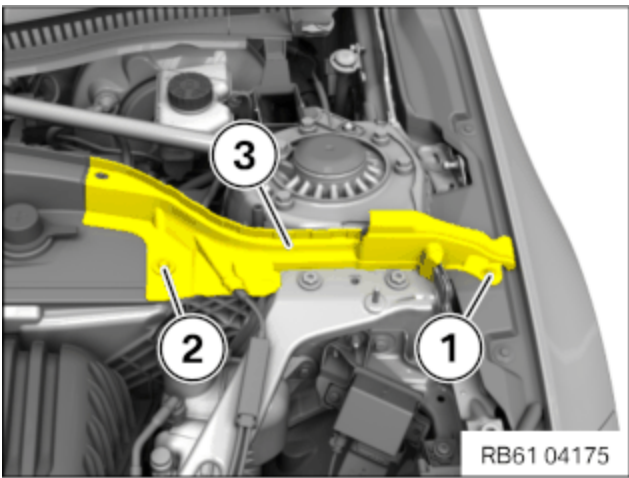

- Loosen expanding rivet (1).
- Loosen screw (2).
- Remove the fixture (3) of the bonnet seal.

#### 5 – Removing front cowl panel cover

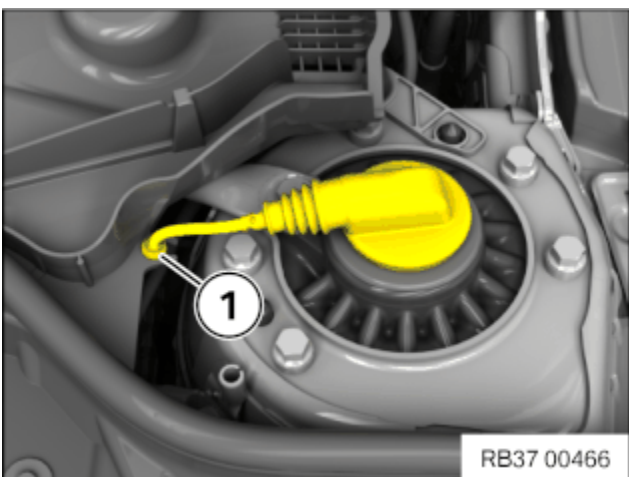

- ▶ **Detach cables (for equipment specification with electronic Damper Control)**
- Unclip the cable (1) from the front cowl panel cover.

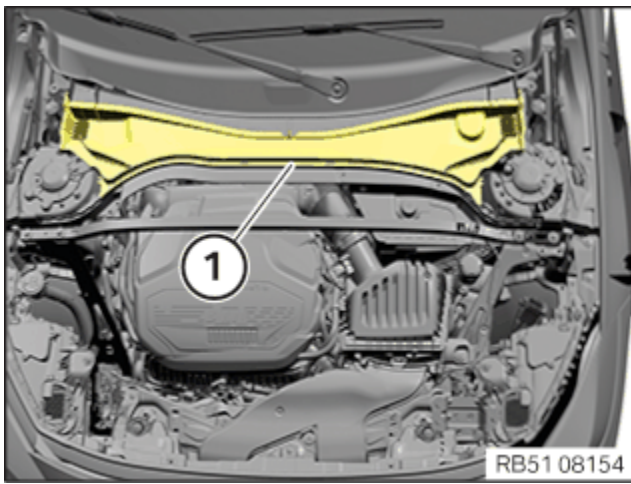

Schematic diagram is for example purposes.  
Some parts may differ in certain details.

- Pull the front cowl panel cover (1) forward out of the rear cowl panel cover and remove.

## 6 – If installed: Remove suspension cross-brace

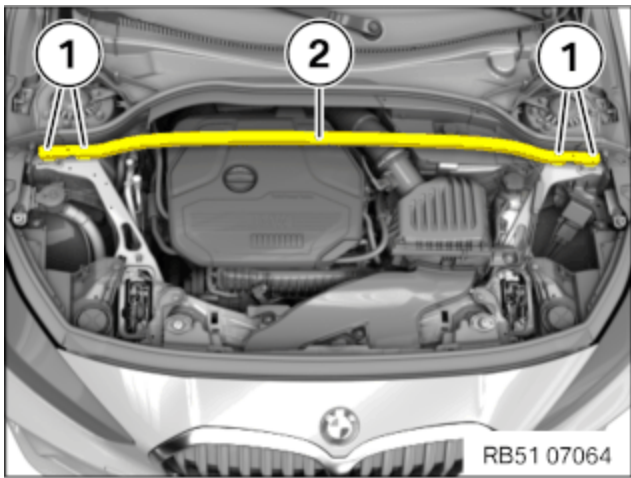

- Loosen screws (1).
- Remove the strut brace (2).

## 7 – Removing the upper bulkhead cover

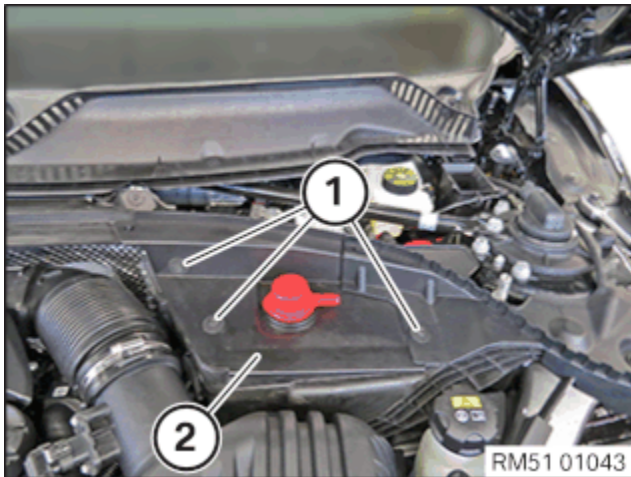

- Loosen screws (1).
- Guide out and remove the cover (2).

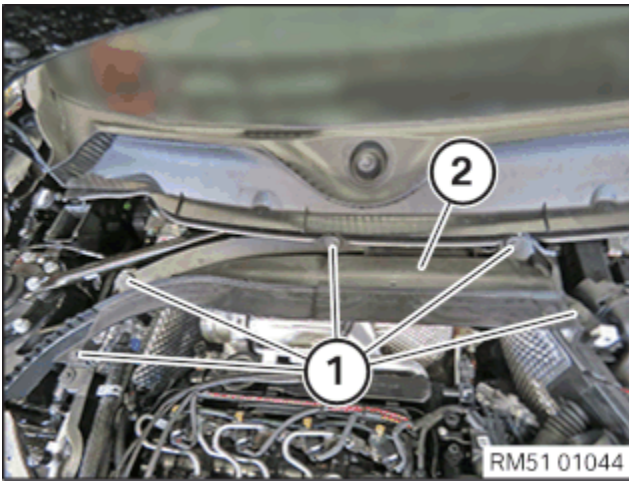

- Loosen screws (1).
- Feed out and remove the upper bulkhead cover (2).

## 8 – Remove the rear bulkhead upper part

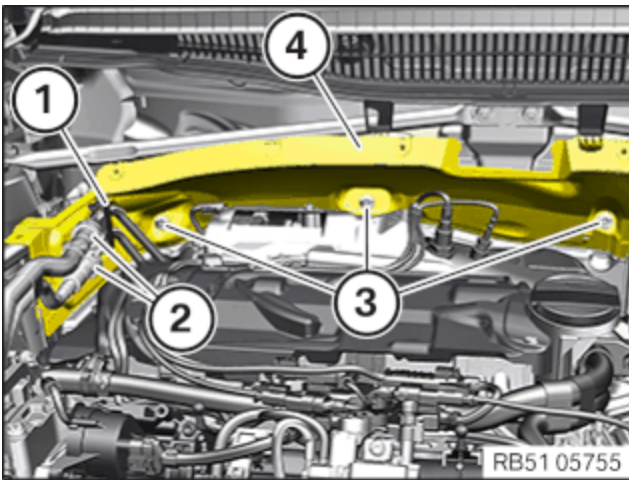

- Unlock holder (1) and disconnect.
- Guide out and remove the fuel lines (2).
- Loosen screws (3).
- Guide out the rear bulkhead upper part (4) and remove.

## 9 – Installing the engine bridge

## Prepared engine bridge

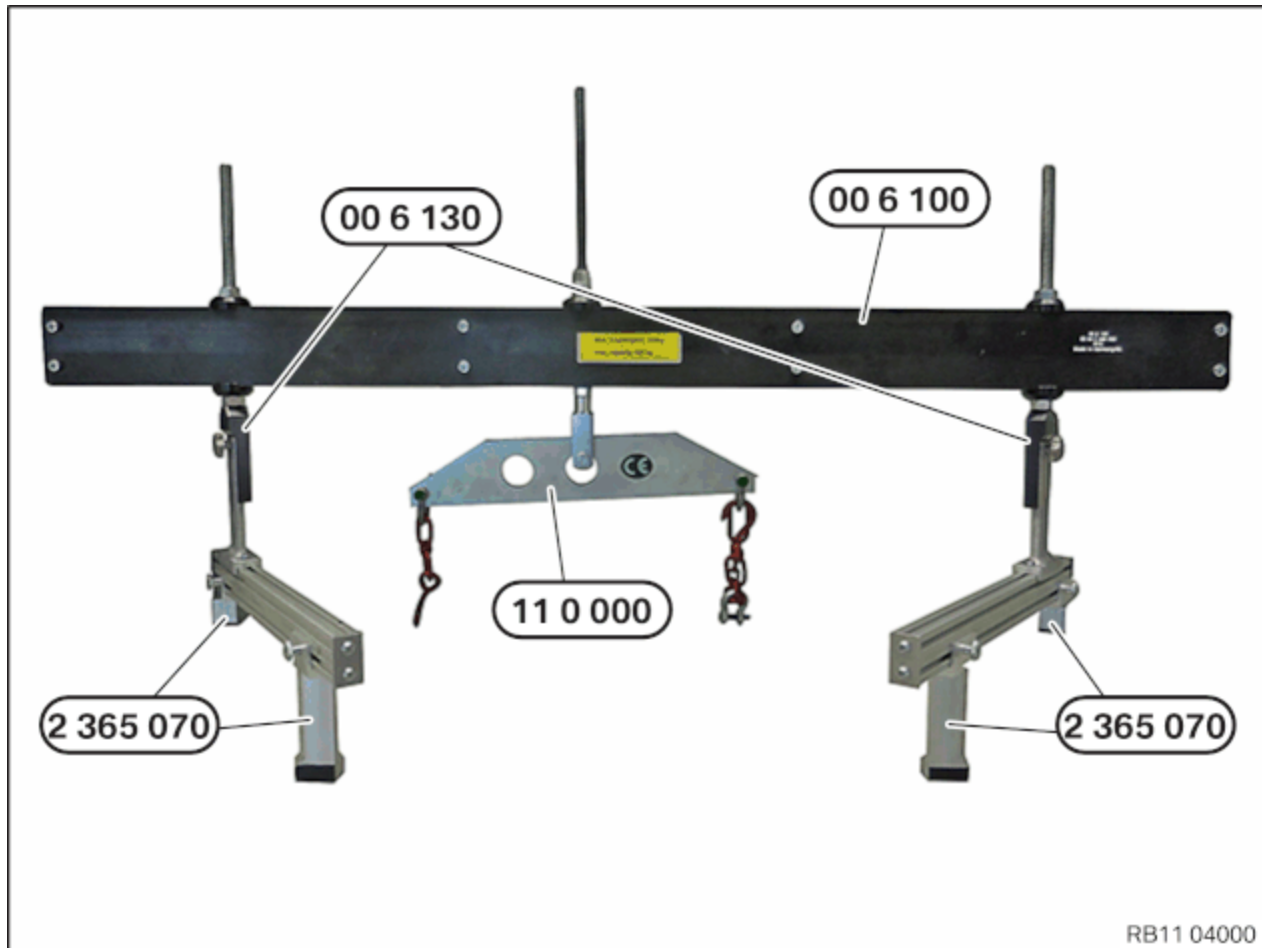

## Prerequisite

Front compartment lid is in service position.



**Components connected to the engine joint or cross member.**

### Danger of injury!

- Check lifting eyes and engine mounting brackets for damage, e.g. cracks.
- Attach the component to correctly mounted engine joints or cross members only.
- Exclusively lift the component, do not move it forwards, backwards or in transverse direction.

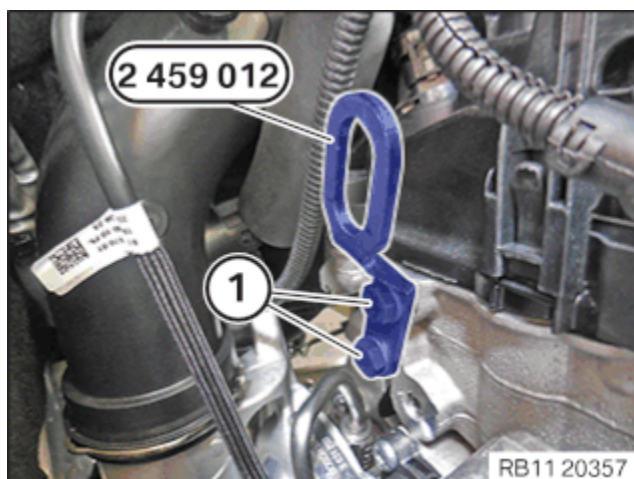

- **If no engine mounting bracket is installed:**
- Guide in and position special tool **2 459 012** on cylinder head.
- Tighten the screws (1) of special tool **2 459 012**.

### Special tool to cylinder head

M8	Tightening torque	21,5 Nm
----	-------------------	---------

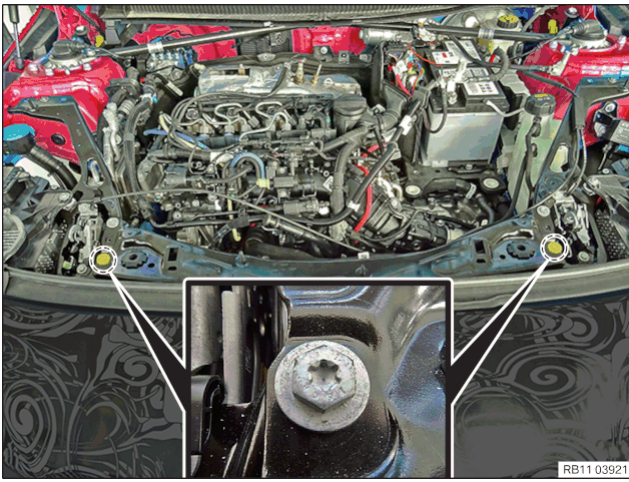

- Release the screws of the cross connection at the front.

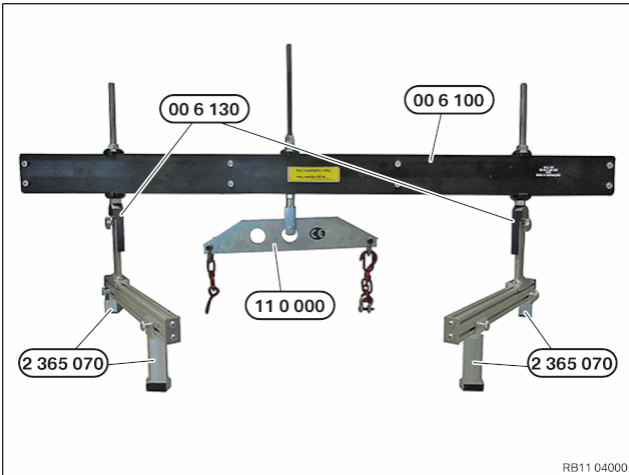

Conduct the following operation with the assistance of a second person.



**Heavy component.**

**Heavy components can lead to injury or damage.**

- Remove and install heavy components with the aid of another person/other persons.

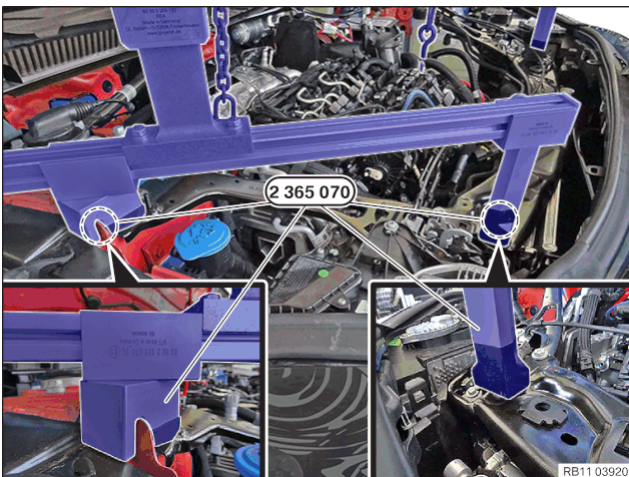

- Position the completed engine bridge on the vehicle with an auxiliary person.
- Position special tool as shown.

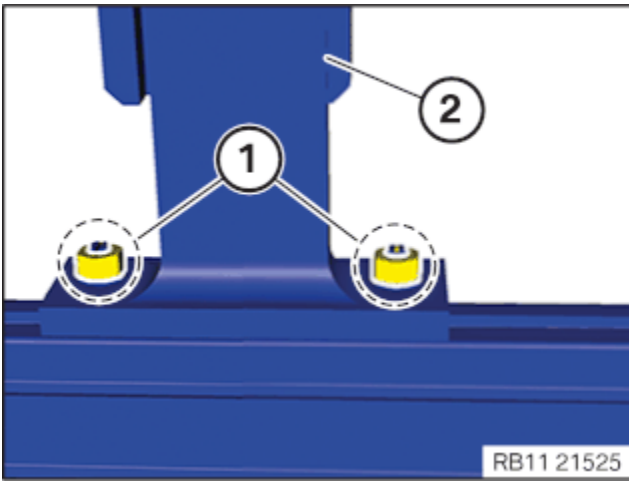

- If necessary, release nuts (1) and position engine bridge (2).

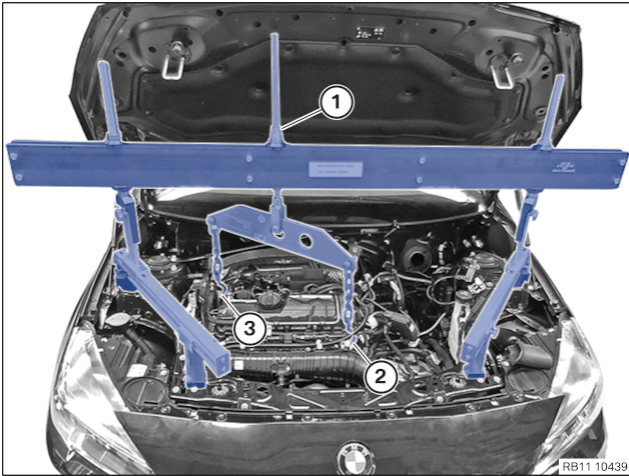

- Attach hooks (2) and (3) in the engine mounting brackets.
- Tighten nut (1) until the engine bridge is slightly pre-tensioned.
- Tighten all adjusting knurled screws and nuts of the engine bridge **0 496 852 (00 6 100)**.

## 10 – Remove the intake neck for intake silencer housing

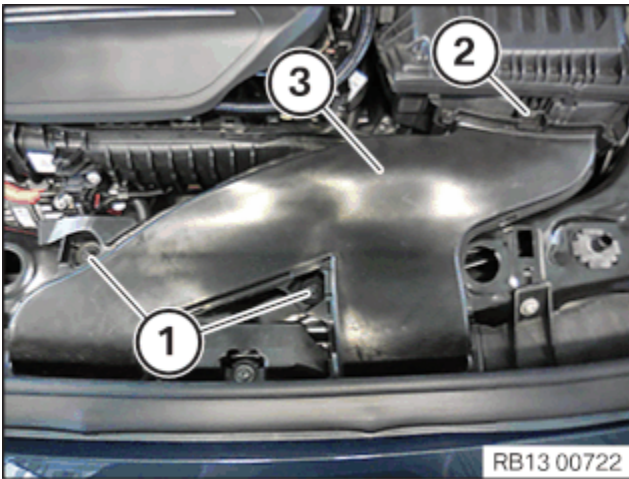

- Loosen nuts (1).
- Loosen the lock (2).
- Guide the intake neck (3) out and remove it.

## 11 – Removing intake silencer housing

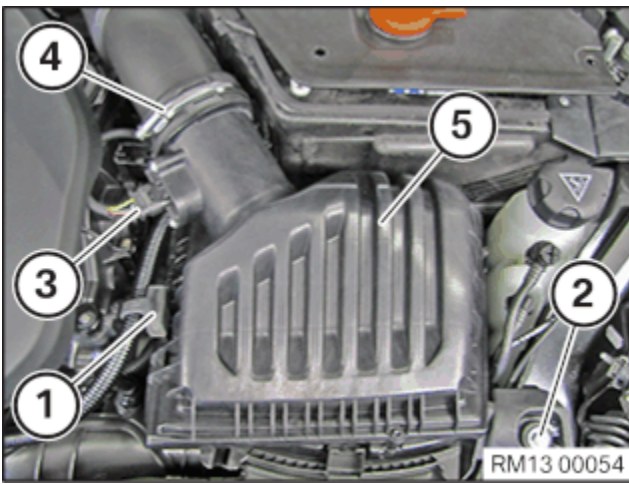

- Loosen the holder (1).
- Loosen screw (2).
- Unlock and release plug connection (3).
- Unfasten clamp (4).
- Pull out and remove the intake silencer housing (5) from the rubber mounts towards the top.

## 12 – Removing the front underbody protection

**i**

Different variants may be installed depending on the vehicle equipment.

### ► Remove front right cross-member



Description is for left component only. Procedure on the right side is identical.

### ▷ Removing the front cross-member



The following work step(s) is / are to be carried out if the specified component(s) is/are fitted.

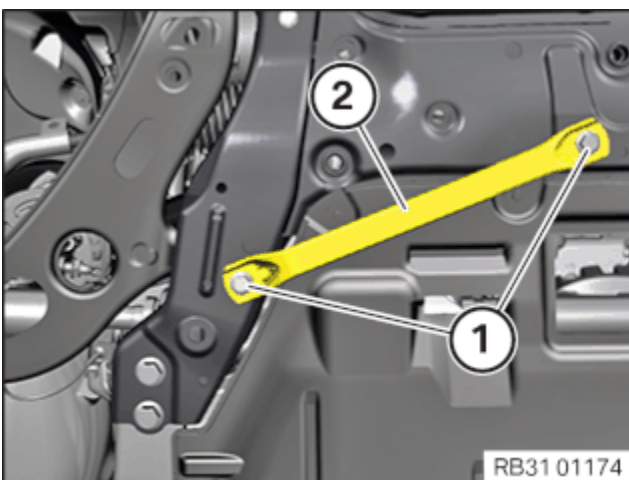

- Loosen screws (1).
- Remove the front cross-member (2).

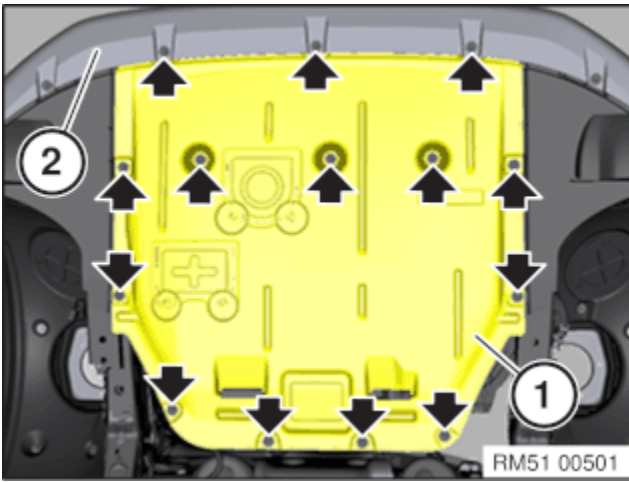

- **Version A:**

Remove screws (arrows).

Feed out the front underbody protection (1) at the bumper panel (2) and remove.

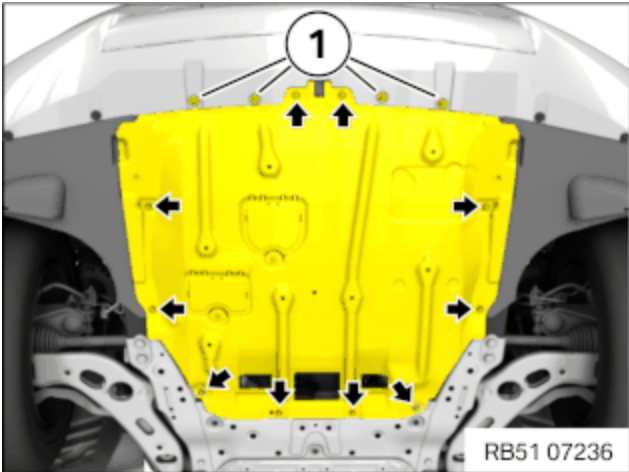

- **Version B (S8SDA):**

Loosen screws (1).

Remove screws (arrows).

Feed out the front underbody protection on the bumper panel and remove.

### 13 – Remove rear underbody protection

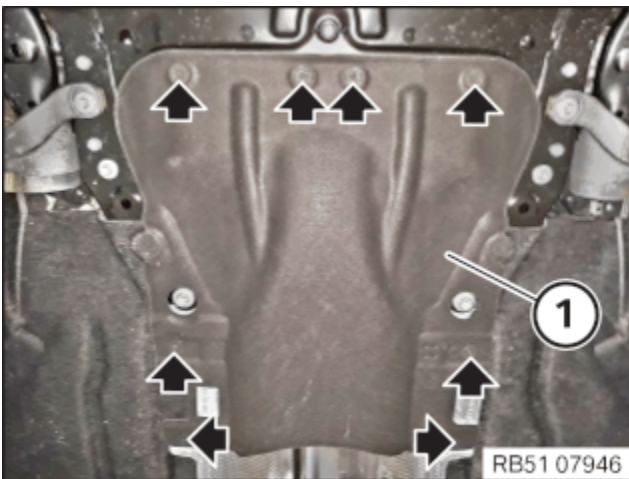

- Remove screws (arrows).

- Guide out rear underbody protection (1) and remove it.

### 14 – Releasing lower steering shaft from steering gear



#### Damage to steering column switch cluster (SZL).

The steering column switch cluster (SZL) or the coil spring cassette may be damaged by twisting of the steering wheel if the lower steering shaft (or the universal joint) is separated from the steering gear or from the steering column.

- After disconnecting the steering shaft (or the universal joint) from the steering gear or from the steering column, secure the steering wheel against twisting.

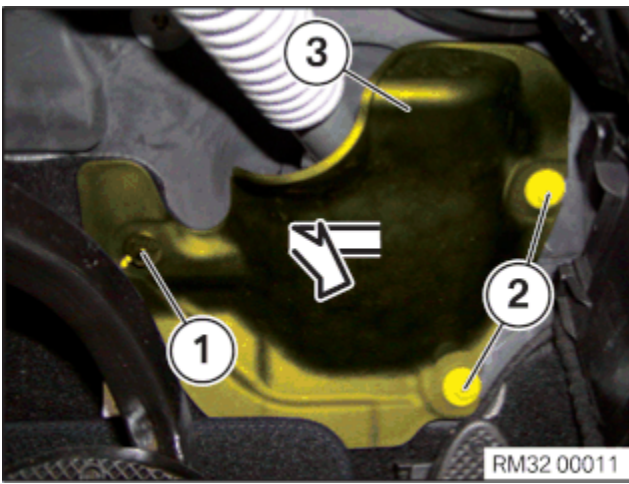

The following work step(s) is / are to be carried out if the specified component(s) is/are fitted.

- Loosen nut (1).
- Slacken the nuts (2).
- Feed out the cover (3) in the direction of arrow and remove it.

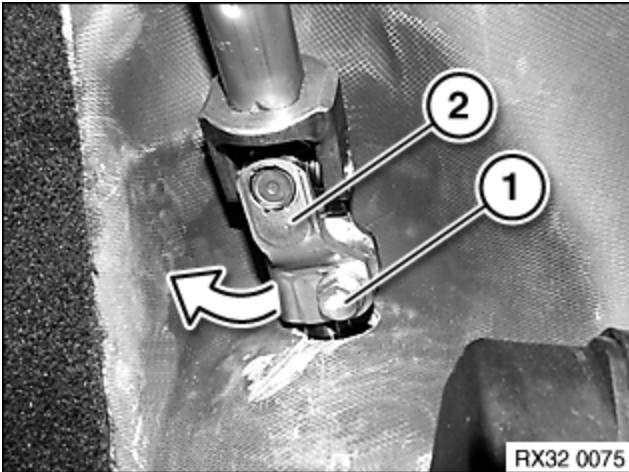

- Loosen screw (1).
- Release the universal joint (2) of the steering shaft at bottom in the direction of arrow from the steering gear and swivel it to the side.

## 15 – Fastening the coolant radiator on the left and right

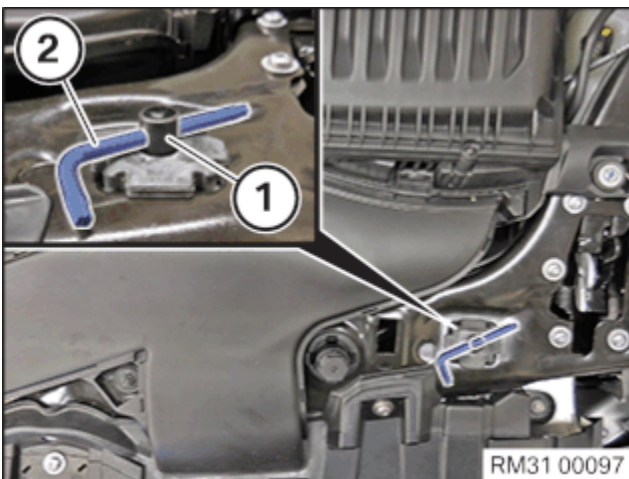

Perform the operations on the left and right side.

- Fasten the coolant radiator to centering pin (1) using a suitable tool (2).

## 16 – Remove the front left and right wheel



Perform the operations on the left and right side.

### ► Removing the wheel



- If several wheels are removed simultaneously: Use a piece of chalk to mark on each tyre the axle and side on which the corresponding wheel is fitted.
- Unscrew the wheel bolts (arrows) and remove the wheel.

Use the matching adapter from tool set (wheel bolt adapter set) to loosen and tighten down the wheel bolt with security code.

## 17 – Removing the bottom left and right cover at the front



Description is for left component only. Procedure on the right side is identical.

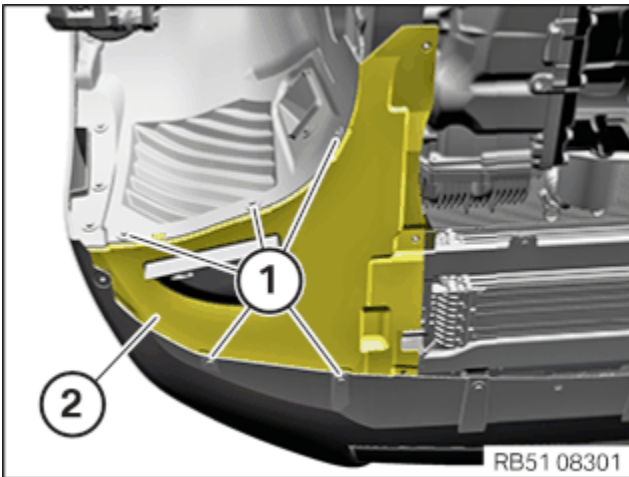

- Loosen screws (1).
- Pull the cover (2) out and remove it.

## 18 – Removing front left and right wheel arch cover



Perform the operations on the left and right side.

► **If installed: Release brake air duct**



To provide a better overview: Schematic diagram with partially hidden components.



- Loosen screws (1).

► **Remove front wheel arch cover**



To provide a better overview: Schematic diagram with partially hidden components.

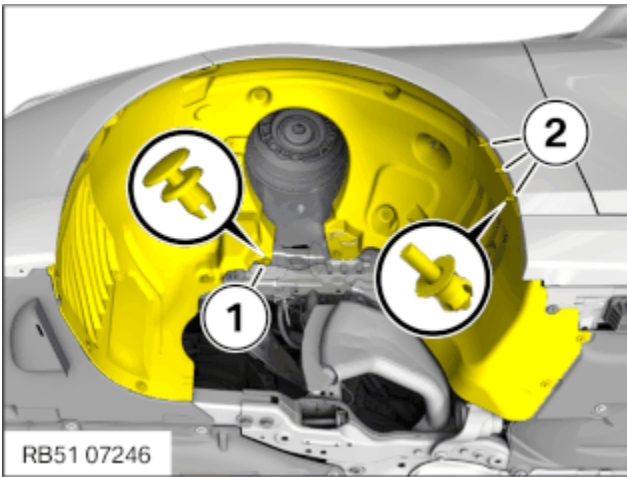

- Loosen expanding rivet (1).
- Loosen the expanding rivet (2).

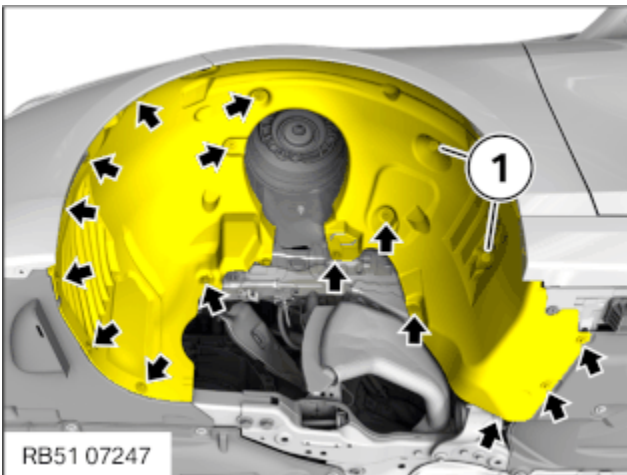

- Loosen nuts (1).
- Remove screws (arrows).
- Guide out and remove the front wheel arch cover.

**19 – With right installation: Detaching ride height sensor cable**

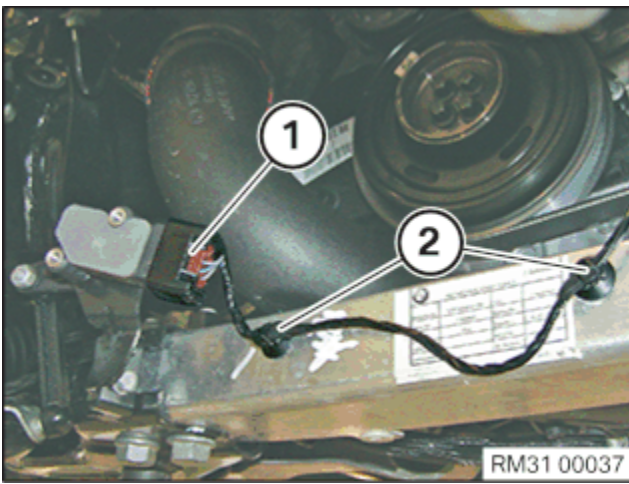

- Unlock plug connection (1) and disconnect.
- Release cable clip (2) from deformation element adapter.

## 20 – Releasing the left and right anti-roll bar from the anti-roll bar link



Perform the operations on the left and right side.

### ► Releasing the anti-roll bar from the anti-roll bar link

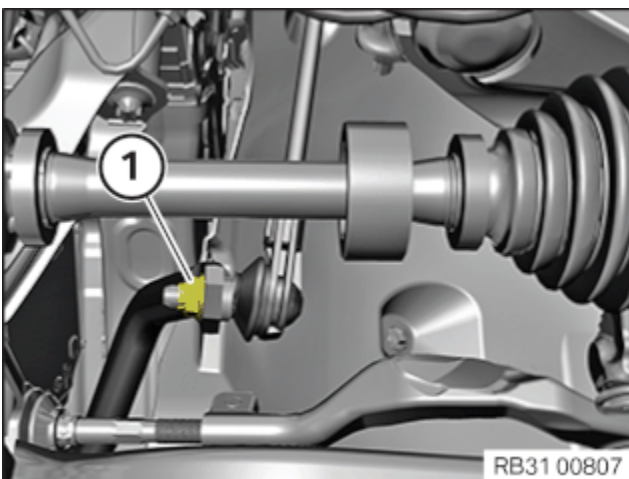

- Loosen nut (1).

**Note** Use the Torx socket for counter support.

- Loosen the anti-roll bar link from the anti-roll bar .

## 21 – Detaching rubber mount from front axle support

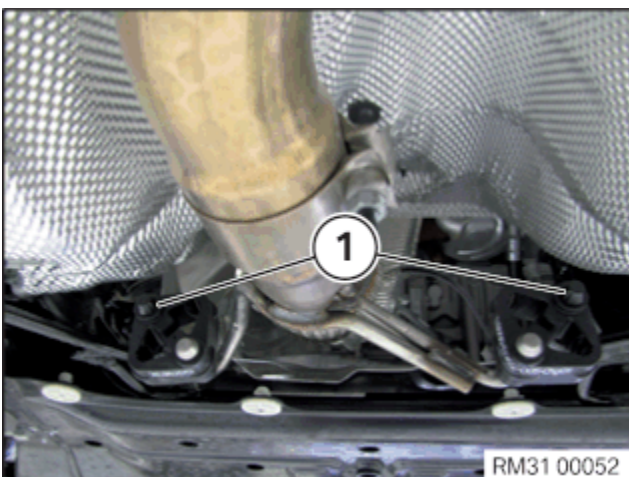

- Spray rubber mount (1) with lubricant and release from holder on front axle support.

## 22 – Disconnecting plug connections from steering gear

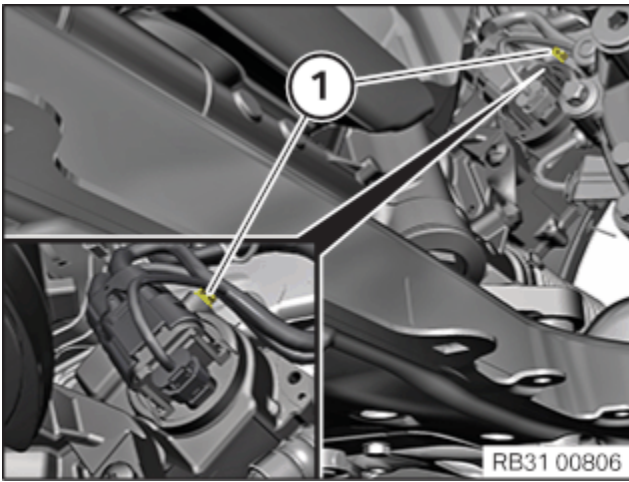

- Disconnect wiring harness (1) from steering gear.

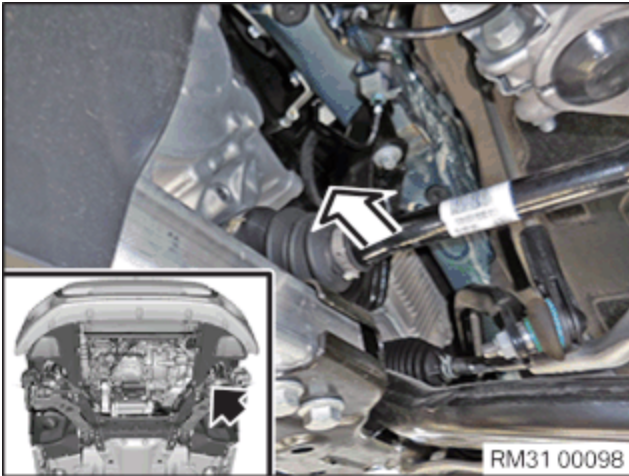

- To unlock the plug connections (see the following work step): Unlock plug connections with right hand in direction of arrow.

The plug connections can be reached via the left output shaft (arrow).

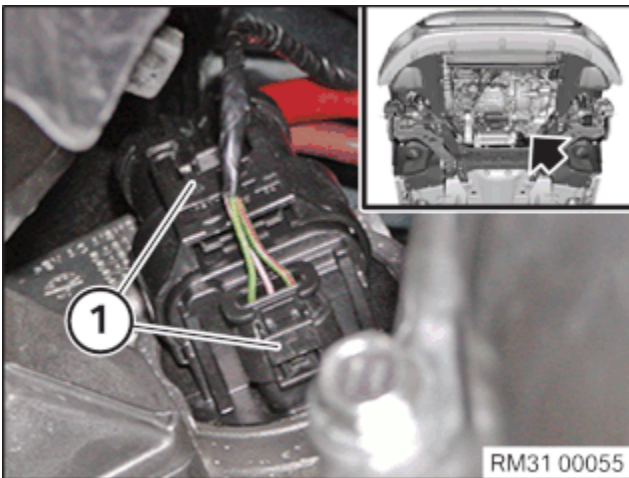

- Unlock plug connections (arrow) (1) and disconnect from the steering gear.
- Make sure when lowering the front axle that the cables are not damaged!

## 23 – Releasing the left and right wishbones from the swivel bearing



Perform the operations on the left and right side.

- **Loosening the wishbone from the swivel bearing**

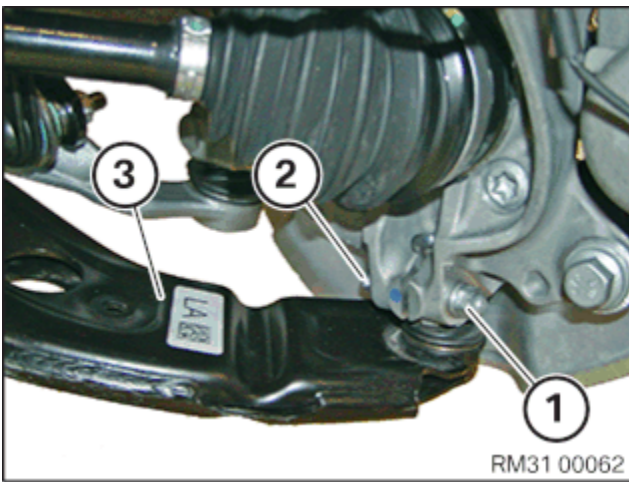

- Loosen nut (1).
- Pull out screw (2).
- Detach the wishbone (3) from the swivel bearing .

## 24 – Release the track rod from the swivel bearing on the left and right



Perform the operations on the left and right side.

### ► Detach the track rod from the swivel bearing

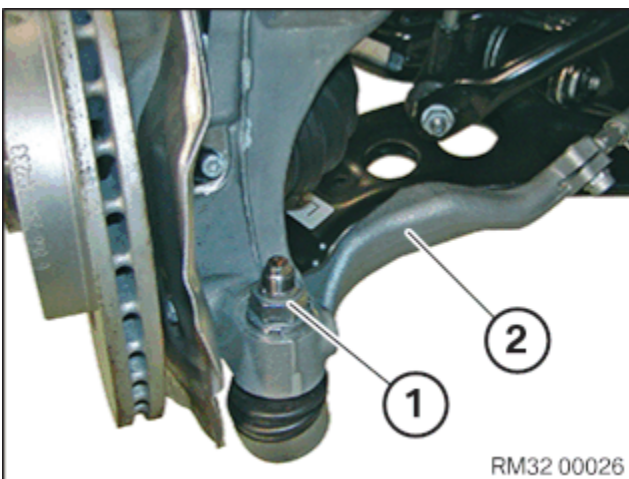

- Loosen nut (1).
- Detach the track rod (2) from the swivel bearing.

## 25 – Releasing the mounted part from the front axle support

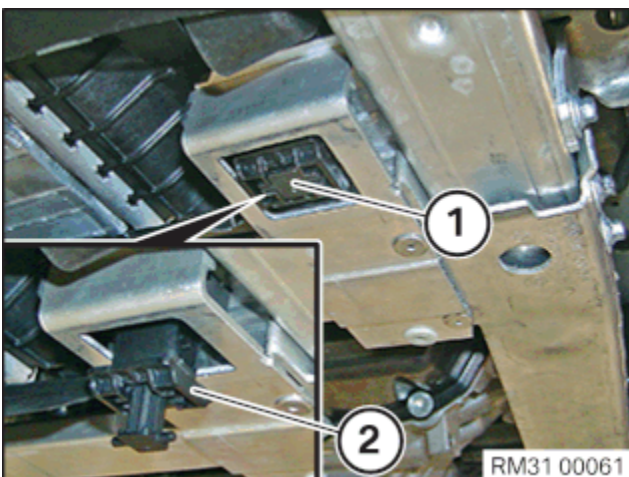

Perform the operations on the left and right side.

- Release the fuse (1) of the lock (2) from the charge air cooler holder.
- Remove the lock (2) completely.

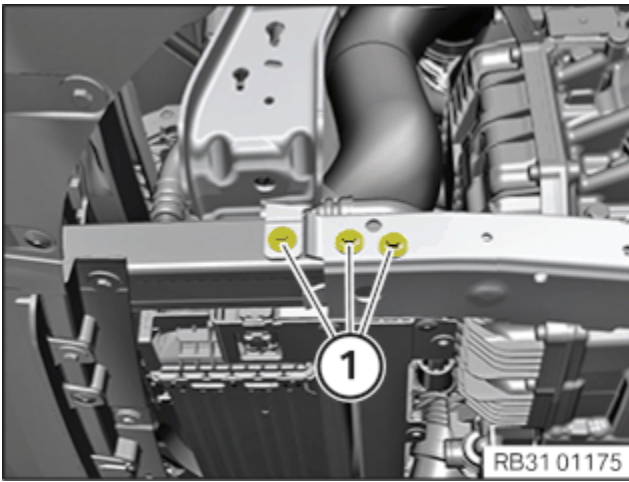

Perform the operations on the left and right side.

- Release the screws (1) on the deformation element.

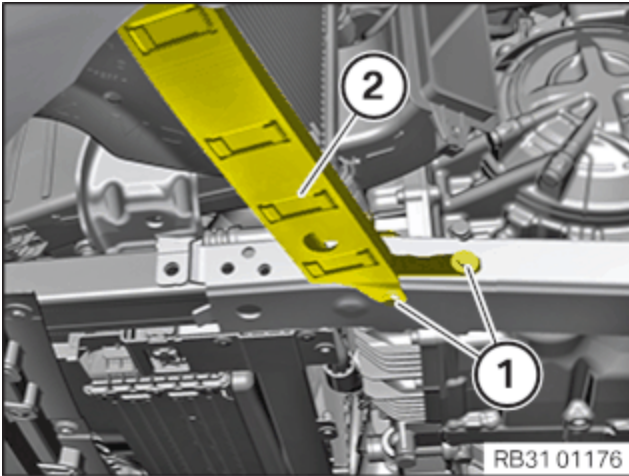

Perform the operations on the left and right side.



The following work step(s) is / are to be carried out if the specified component(s) is/are fitted.

- Loosen screws (1).
- Feed out and remove the holder (2) for external radiator.
- Release the screw (2).
- Release the holder with rubber mount (3) from the front subframe (1).

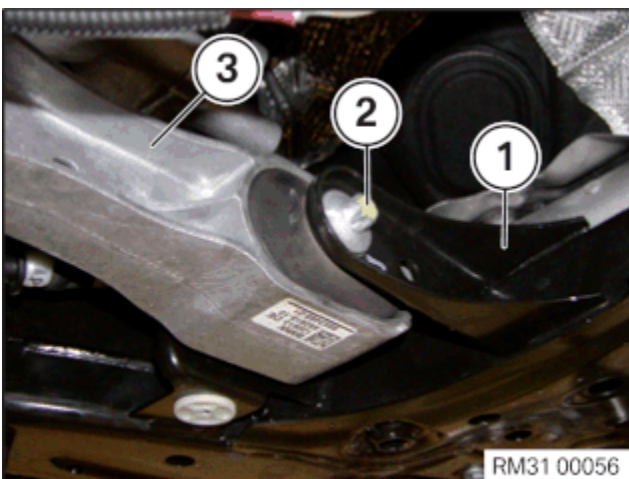

Perform the operations on the left and right side.

- Loosen screws (1).

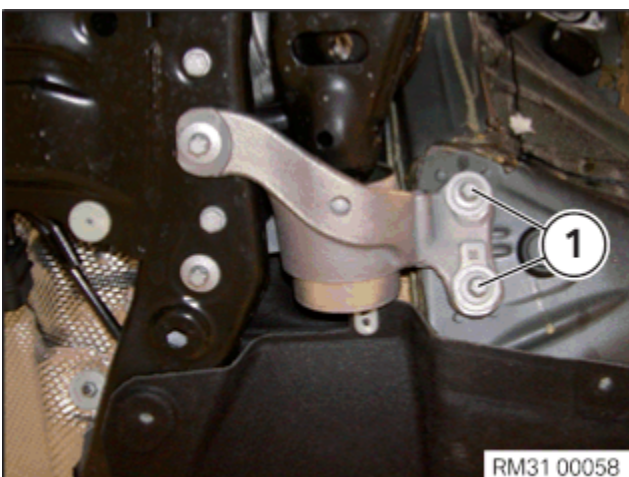

## 26 – Preparing the special tool

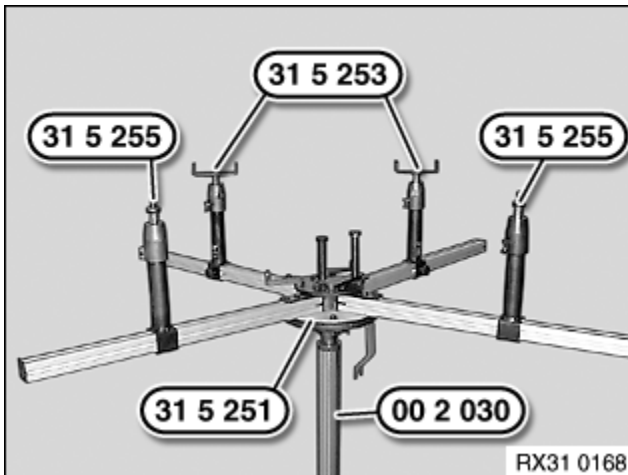

- Connect the special tool to the special tool **0 490 133 (00 2 030)** with the help of an auxiliary person.
- Insert the special tools in the telescopic supports of a profile rail pair.
- Insert the special tools in the telescopic supports of the other profile rail pair.

**Note** In a profile rail pair, 2 profile rails are connected to one another by gearing.

## 27 – Remove front axle completely

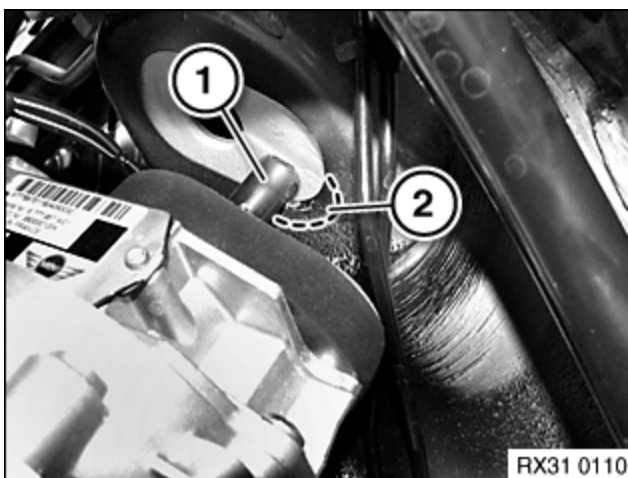

**Collision of the torsion bar of the EPS with the bulkhead.**

**Damage to the electromechanical steering gear (EPS)**

- When lowering and lifting the front axle support, ensure that the torsion bar of the electromechanical steering gear (EPS) does not collide with the bulkhead.

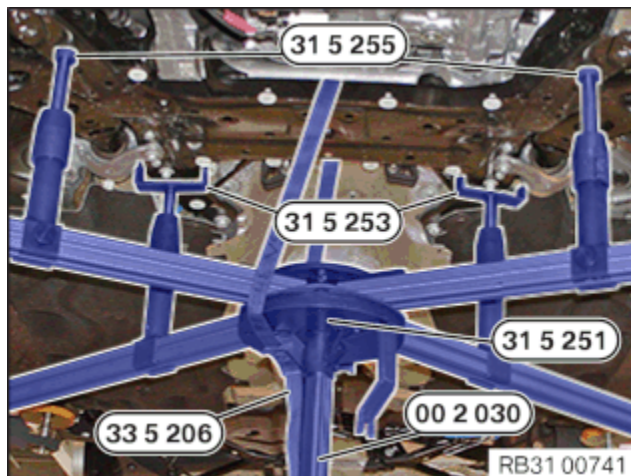

- Ensure that torsion bar (1) of the electromechanical steering gear (EPS) in area (2) does not collide with the bulkhead!

- Align special tools and to front axle support.
- Support the front axle support by operating the special tool **0 490 133 (00 2 030)**.

**Note** The centre of gravity of the front axle support must be positioned centrally over the workshop jack!

- Secure front axle support with special tool to special tool .

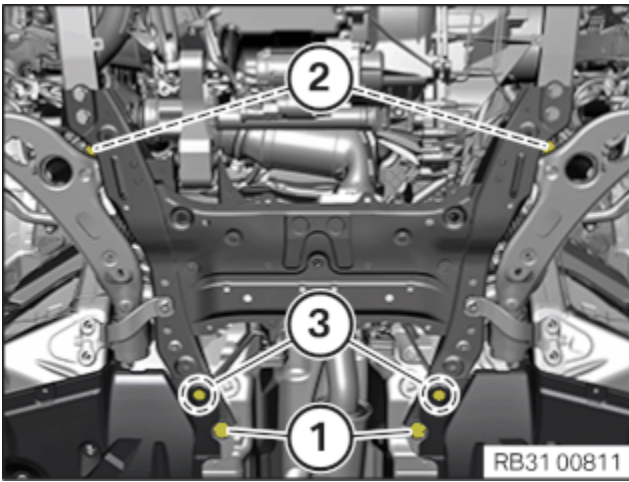

- Release screws (3) on the underbody panelling.
- Release screws (1) on the rear front axle support.
- Release the screws (2) on the front subframe at the front.
- Bend the underbody panelling in the areas of the screws (3) to the side.
- When lowering, feed out the rear front axle support on the underbody panelling and release the charge air cooler from the rubber mounts.
- Completely lower the front axle with the universal jack and remove.



Note the information on thread repairs using Helicoil thread inserts.  
For more information see: 41 00 ... Notes on repairing threads

- Check thread for damage; if necessary, repair with Helicoil thread insert.

## 28 – Release transmission-side bolting connection oil sump

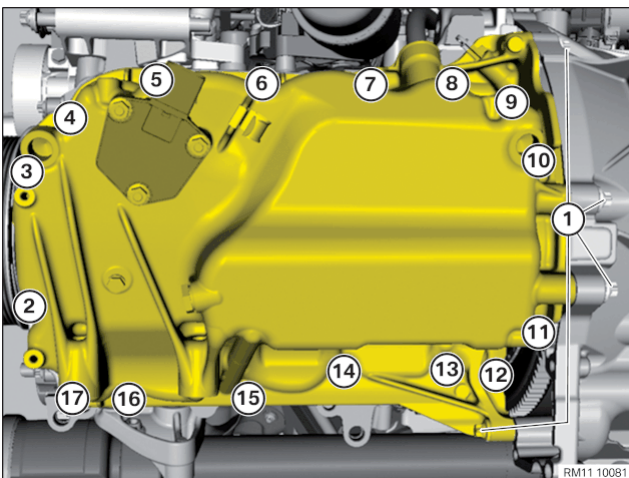

- Unscrew the bolts (1) from the transmission.

## 29 – Partially removing the left output shaft

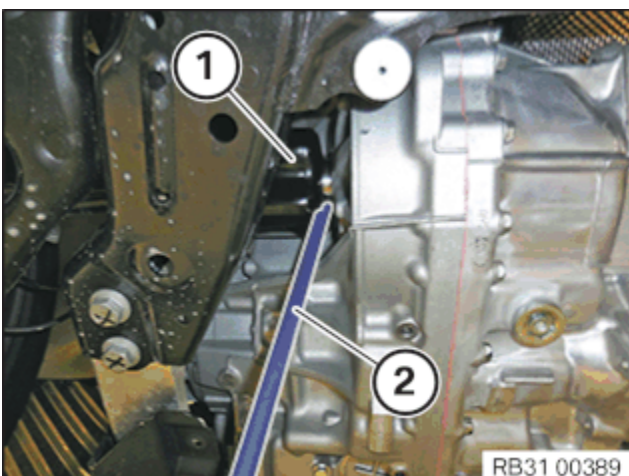

- Protect the output shaft (1) from falling.
- Lever out the output shaft (1) with a mounting lever (2) from the transmission.
- Tie up output shaft (1).

► Remove the left/right radial shaft seal on the differential (manual gearbox)



**Materials harmful to health.**

**Contact with fluids harmful to health!**

- Note and follow safety information on containers.
- Conduct all work in appropriate personal protective equipment only.



**Damage to the transmission.**

**Damage to the transmission by unapproved transmission oil.**

- Use only the approved transmission oil.
- Check the transmission oil level after completing the repair.

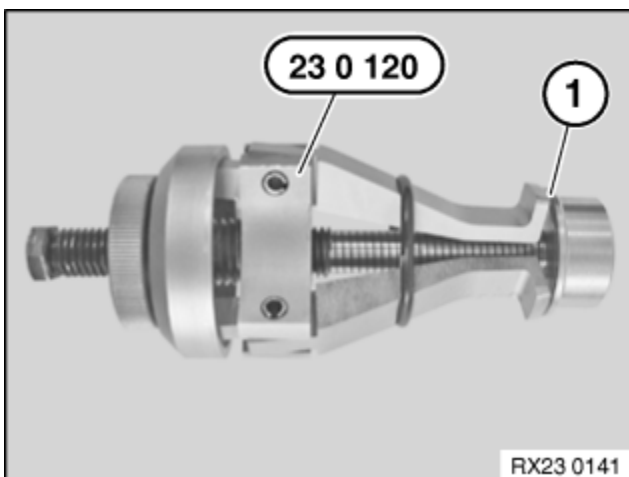

- Prepare special tool .  
The distance (1) must be < 1 mm.

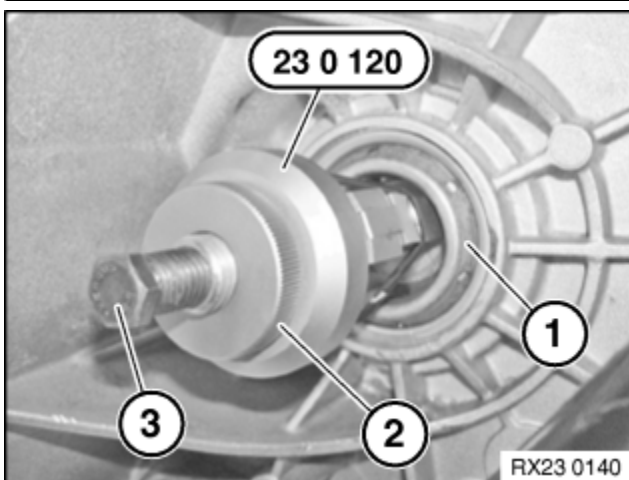

- Insert special tool in the radial shaft seal (1) up to the limit position.
- Spread out the claws by turning the nut (2).
- Screw in screw (3) and pull off the radial shaft seal.

**30 – Removing right output shaft partially**

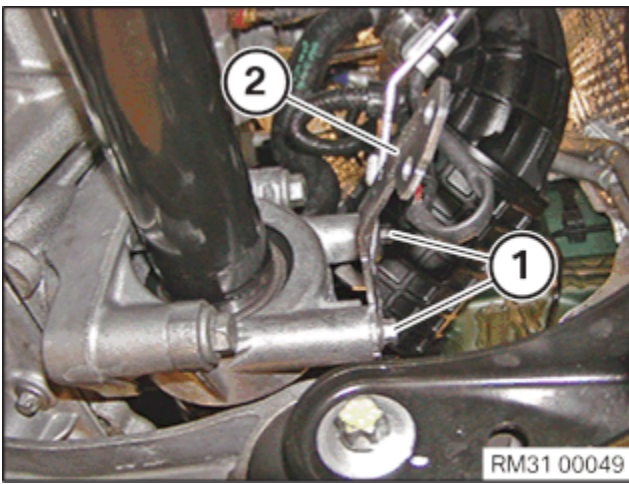

- If necessary, unscrew the bolts (1) and remove the holder (heat shield) (2).

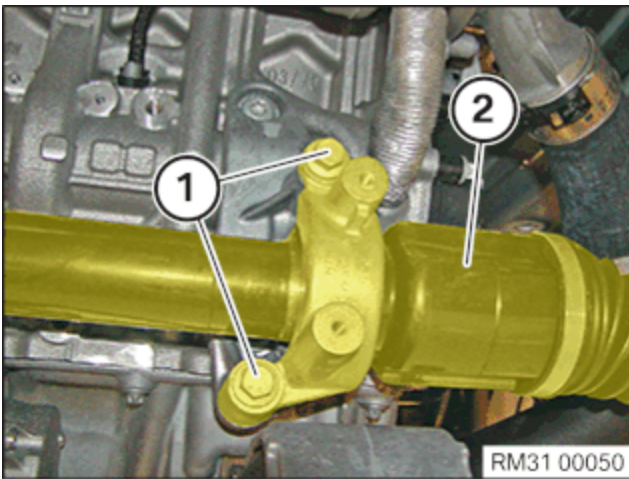

- Loosen screws (1).
- Pull out the output shaft (2) from the transmission.
- Tie up output shaft (1).

► Remove the left/right radial shaft seal on the differential (manual gearbox)



**Materials harmful to health.**

**Contact with fluids harmful to health!**

- Note and follow safety information on containers.
- Conduct all work in appropriate personal protective equipment only.



**Damage to the transmission.**

**Damage to the transmission by unapproved transmission oil.**

- Use only the approved transmission oil.
- Check the transmission oil level after completing the repair.

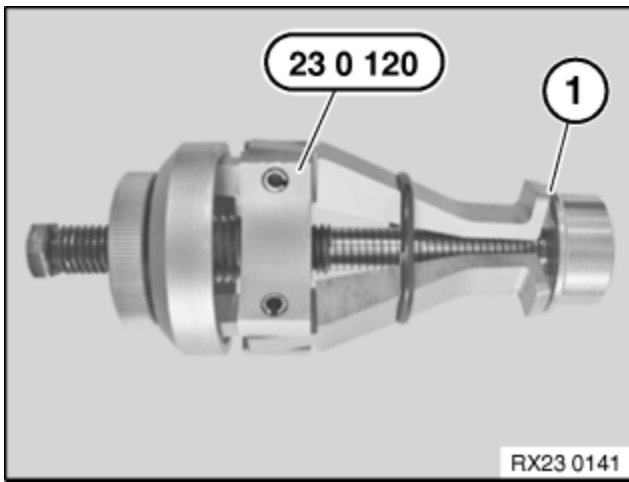

- Prepare special tool .
- The distance (1) must be < 1 mm.

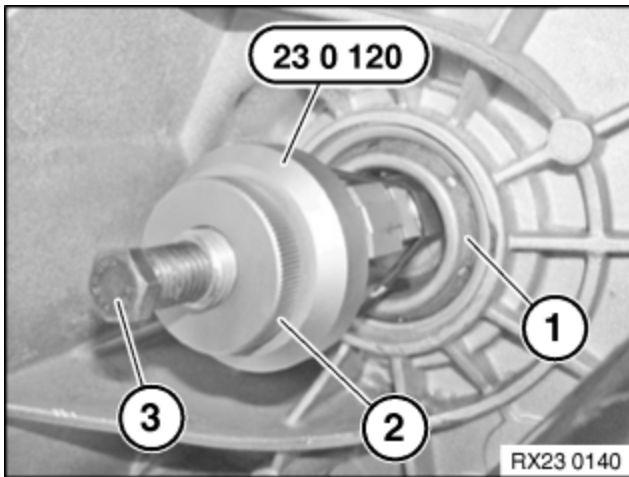

- Insert special tool in the radial shaft seal (1) up to the limit position.
- Spread out the claws by turning the nut (2).
- Screw in screw (3) and pull off the radial shaft seal.

### 31 – Removing starter motor



**Hot surfaces.**

**Risk of burning!**

- Perform all work only on components that have cooled down.



**Working on 12 V vehicle electrical system.**

**Risk of short circuits! Risk of fire!**

- Make sure that **no charger** is connected to the jump start support point in the engine compartment.
- Detach battery earth lead from battery.
- With auxiliary batteries: Detach all battery earth leads from additional batteries.



## Electrostatic discharge.

### Damage to or destruction of electrical components.

- Leave electrical components in original packaging until just before they are installed. Use the original packaging only for any return shipments. Always package removed components straight away.
- Read and comply with user information on using the associated special tool 12 7 060.
- Only touch the housings of electrical components. Do not touch pins or multi-pin connectors directly.
- Wear electrically conductive clothing and antistatic shoes (with ESD symbol).
- For additional information see: 61 35 ... Notes for ESD protection (electrostatic discharge)

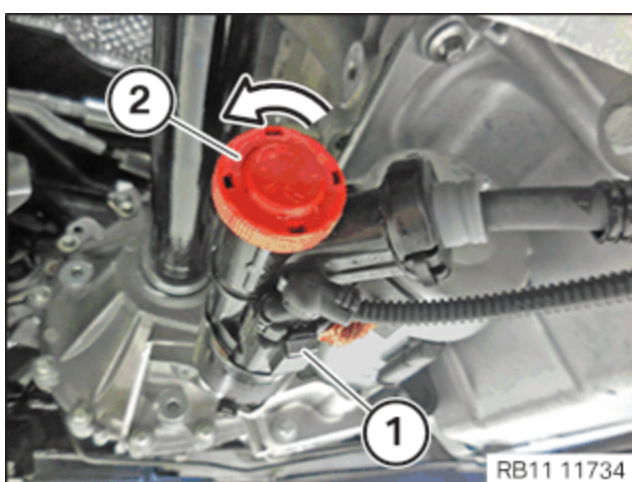

- Unlock and loosen connector (1).
- Detach the sealing cap (2) in the direction of the arrow.
- Feed out and remove the sealing cap (2).

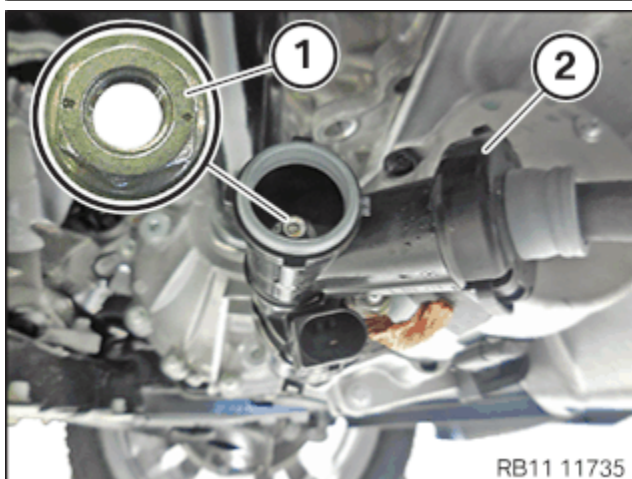

- Unfasten nut (1).
- Feed out the positive battery cable (2) of the starter motor and set it aside.

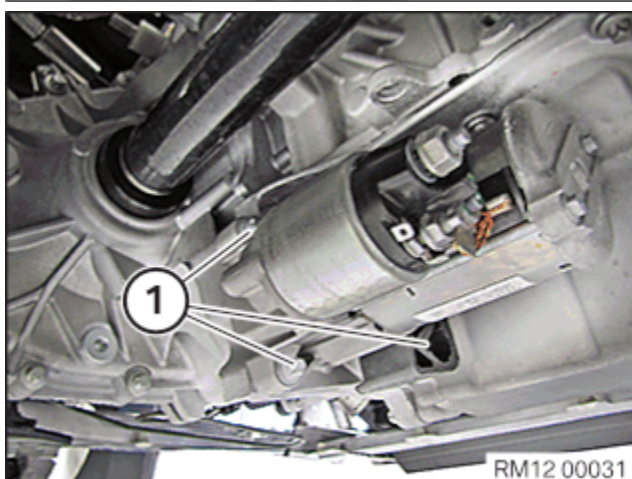

- Loosen screws (1).
- Feed out starter motor and remove.

## MAIN WORK

---

### 32 – Removing the manual gearbox (GS6-59DG, GS6X60DA)



**Materials harmful to health.**

**Contact with fluids harmful to health!**

- Note and follow safety information on containers.
- Conduct all work in appropriate personal protective equipment only.



**Damage to the engine block.**

**Serious damage to the engine block and transmission due to damaged and corroded bolts.**

- It is imperative that protruding threads of the transmission bolts are checked for corrosion and damage prior to removal.
- It is imperative that all rust is removed from corroded threads and that they are cleaned prior to removal.
- Renew rusted and damaged bolts.

#### ► Remove electronics box

### Prerequisite

Battery earth lead is disconnected.



**Electrostatic discharge.**

**Damage to or destruction of electrical components.**

- Leave electrical components in original packaging until just before they are installed. Use the original packaging only for any return shipments. Always package removed components straight away.
- Read and comply with user information on using the associated special tool 12 7 060.
- Only touch the housings of electrical components. Do not touch pins or multi-pin connectors directly.
- Wear electrically conductive clothing and antistatic shoes (with ESD symbol).
- For additional information see: 61 35 ... Notes for ESD protection (electrostatic discharge)



**Damage to wires when disconnecting connectors and plug connections.  
Sheared wires can cause a short circuit.**

- Do not pull on the wires when disconnecting connectors and plug connections.



Follow instructions for removing and installing control units.

For additional information see: 12 00 ... Notes on removal and installation of control units



Disconnecting control units may cause fault code entries and functional limitations. Fault code entries must be read out and deleted if necessary.

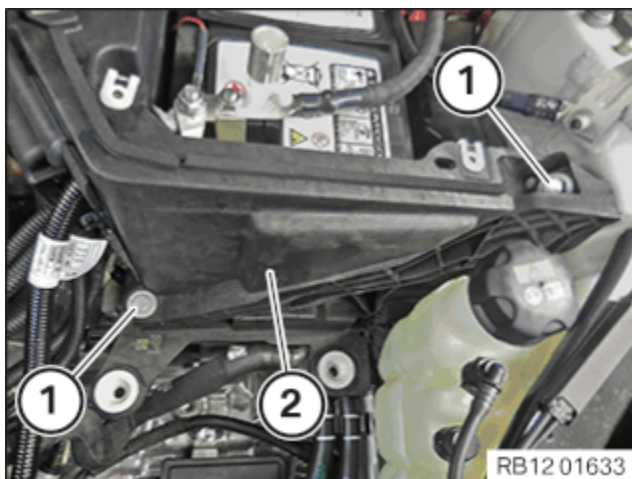

- Loosen screws (1).
- Guide out the tension strut (2) toward the top and remove it.

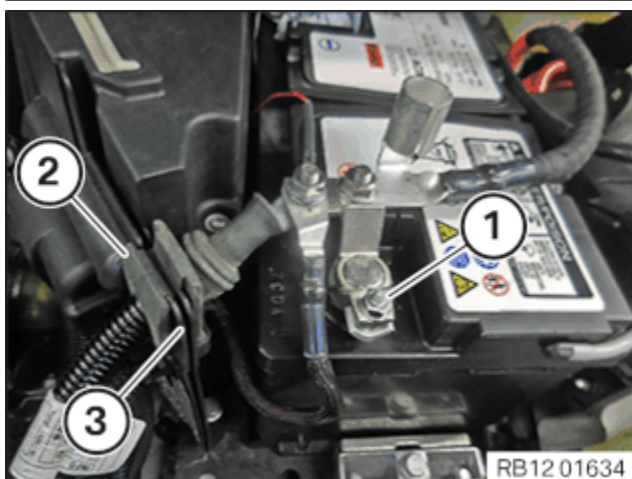

- Undo positive battery terminal (1).
- Feed out positive battery terminal (1) and set aside.
- Guide the positive battery cable (2) out of the holder (3) and lay to one side.

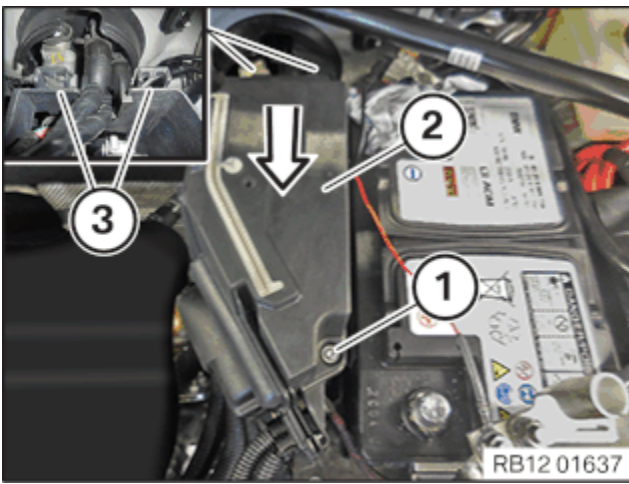

- Loosen screw (1).
- Unlock cover (2) and thread out and remove from the guides (3) in the direction of arrow.

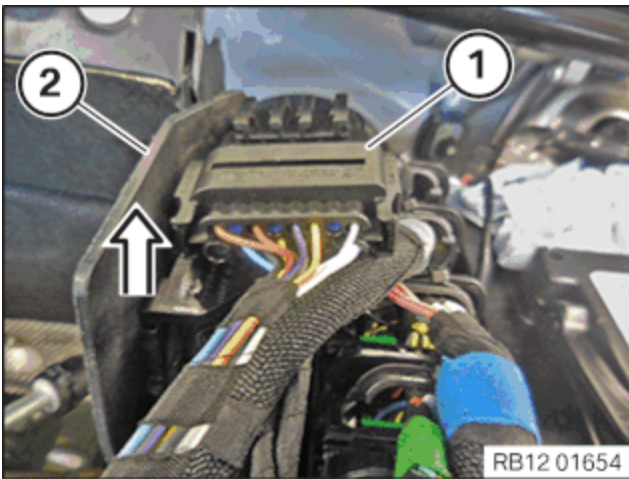

- Feed out and remove the plug connection (1) from the electronics box (2) in the direction of arrow.
- Unlock plug connection (1) and disconnect.

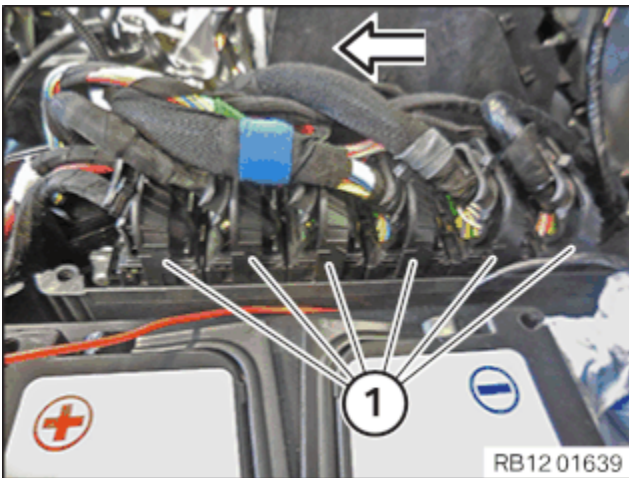

- Unlock and release the plug connections (1) in the direction of the arrow.
- Feed out connector (1) and place to one side.

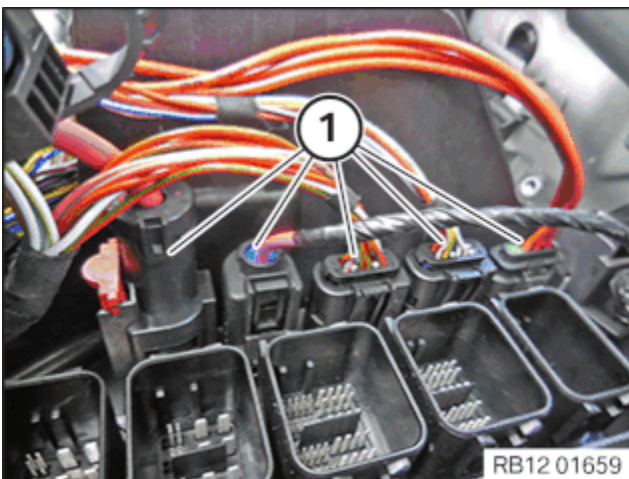

- Unlock plug connections (1) and disconnect.

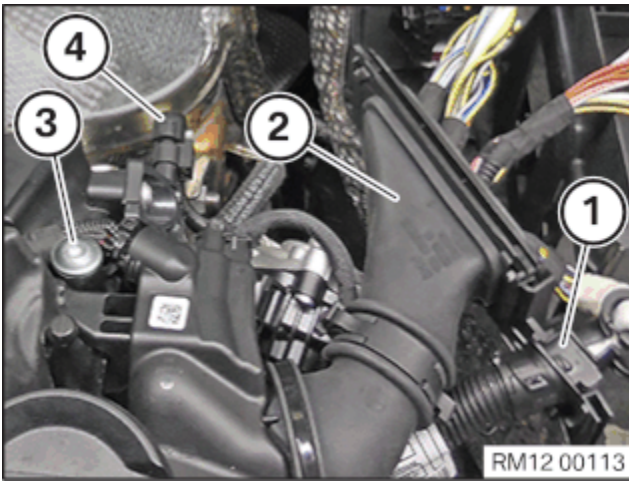

- Detach the wiring harness (1) from the electronics box.
- Detach the wiring harnesses (2) from electronics box.
- Loosen screw (3).
- Lay the wiring harnesses (1) and (2) to a side.
- Unlock the plug connection (4) and disconnect and pull off from the differential pressure sensor.

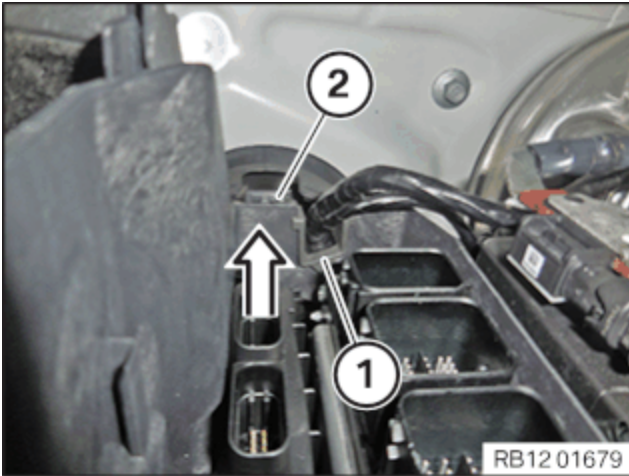

- Unlock and loosen holder (1).
- Guide the holder (1) out of the electronics box (2) in direction of arrow and set it aside.

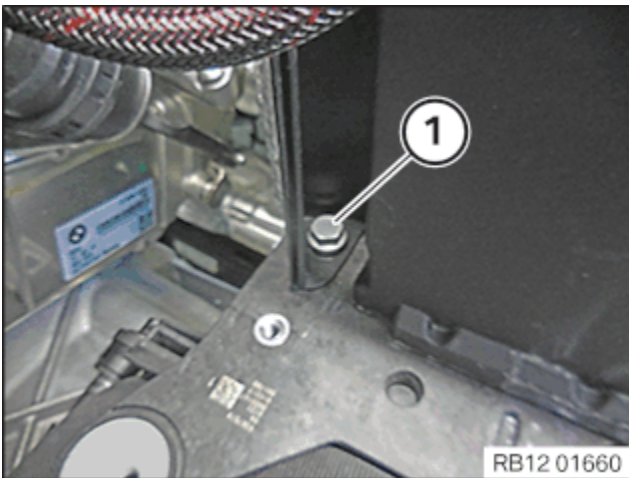

- Loosen screw (1).

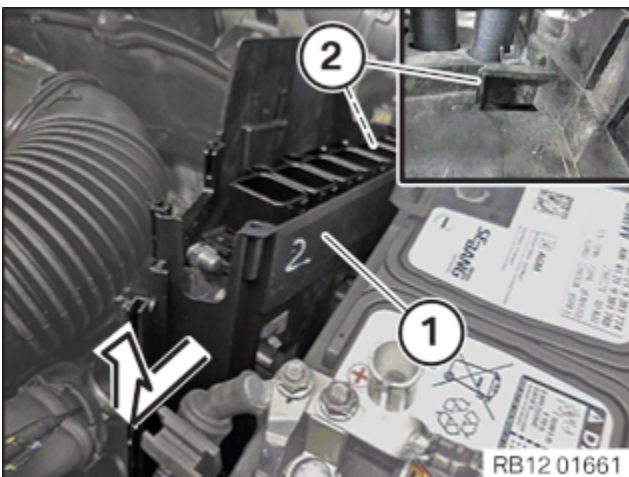

- Guide the electronics box (1) out of the guide (2) in direction of arrow and remove.

## ► Removing the system battery partially

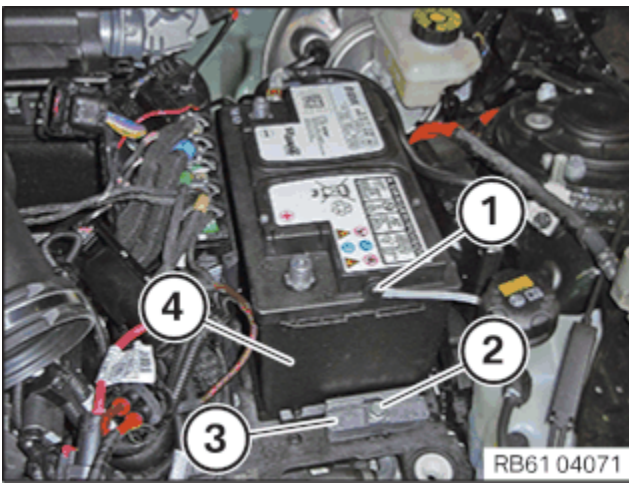

- Pull off the vent hose (1).
- Unscrew the screw (2) and remove the holder (3).
- Remove the system battery (4).

### ► Remove battery holder

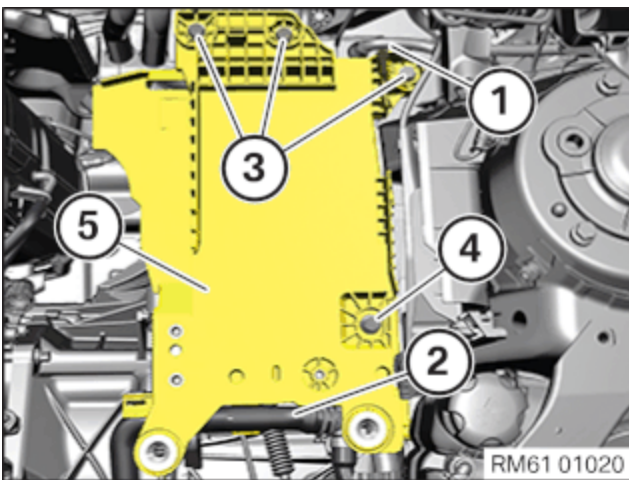

- Detach the cable clip (1) from the battery holder (5).
- Detach the coolant line (2) from the battery holder (5).
- Loosen screws (3).
- Loosen screw (4).
- Thread out and remove the battery holder (5).

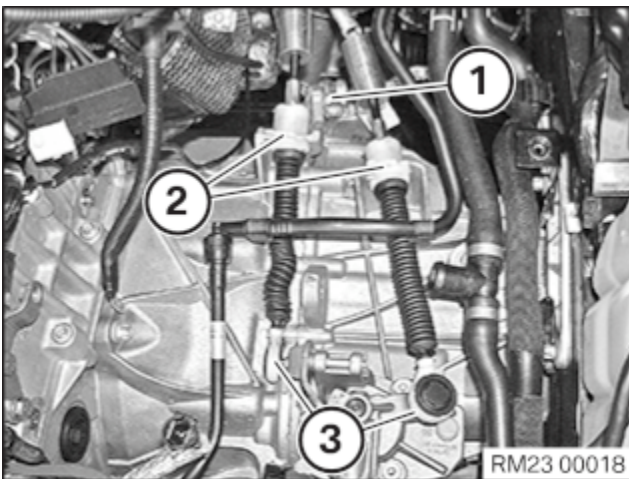

- Release clip on the limit position or holder (2) and bend the tabs slightly away from the limit position or holder (2).
- Unscrew the bolt (1) and detach the ground strap from the transmission.

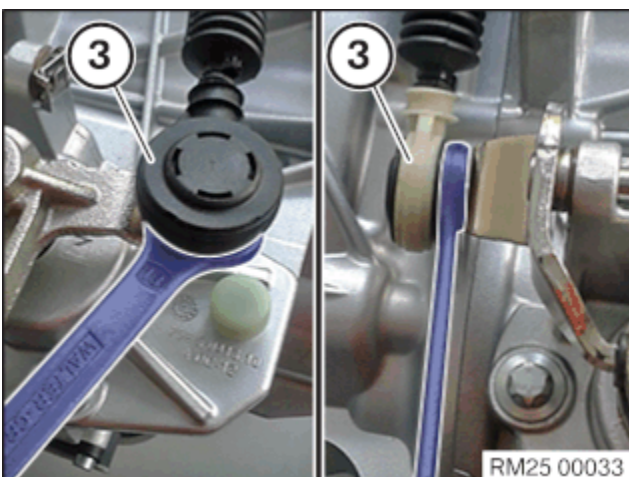

- Lever the fixtures (3) of the selector lever cables away from the ball joints with an open-end spanner (SW13).

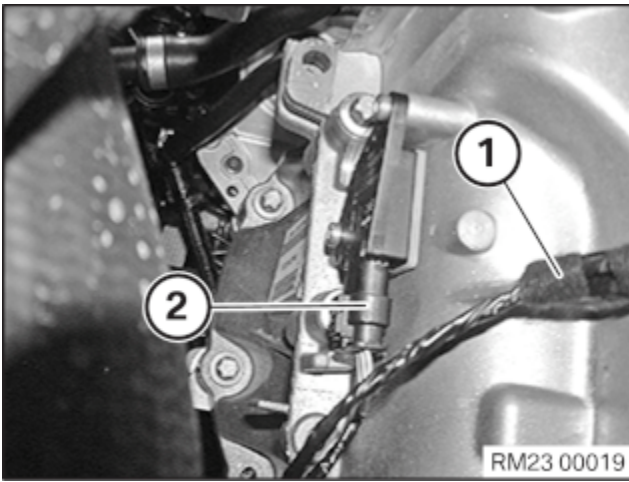

- Disconnect the plug connection (2) of the gear sensor.
- Detach the cable (1) with the holder from the transmission.

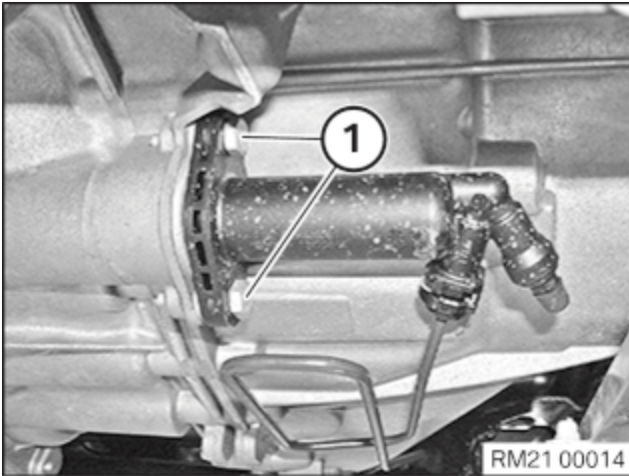

- Relieve tension on clutch slave cylinder slowly; otherwise air will be drawn in through sealing cup. Pressure line of clutch slave cylinder remains connected.
- Unscrew the bolts (1) and remove the clutch slave cylinder.

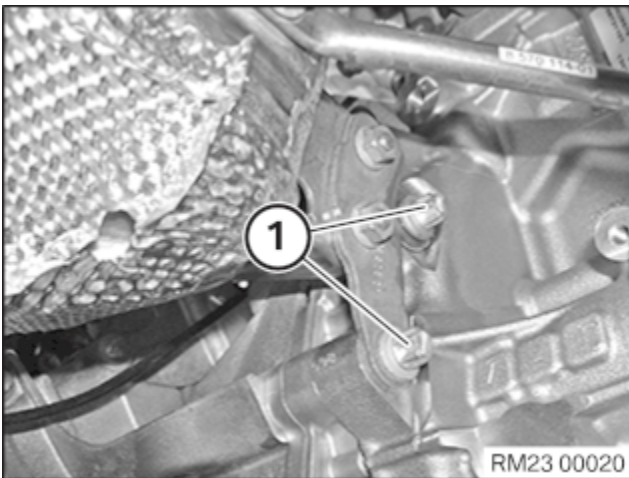

- Loosen screws (1).

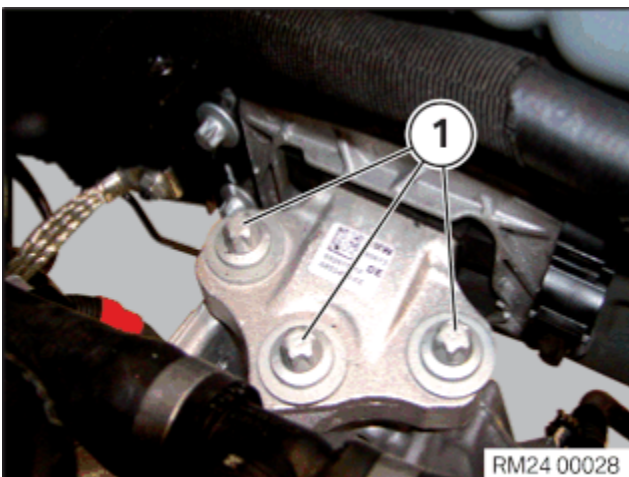

- Loosen screws (1).

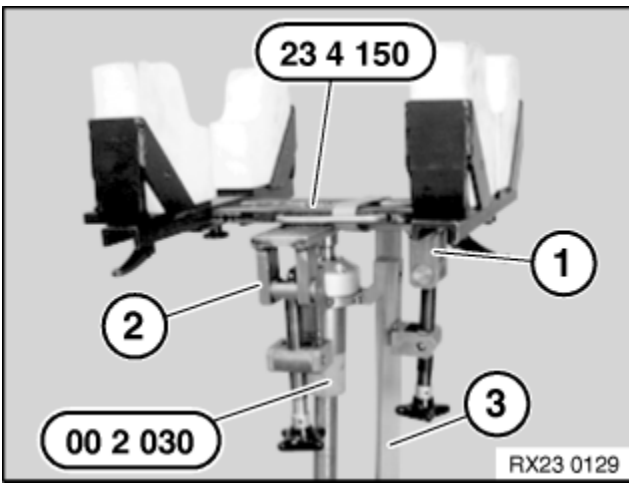

- Support the transmission with special tools **0 490 133 (00 2 030)** and .
- Secure the transmission with the tensioning strap (3).

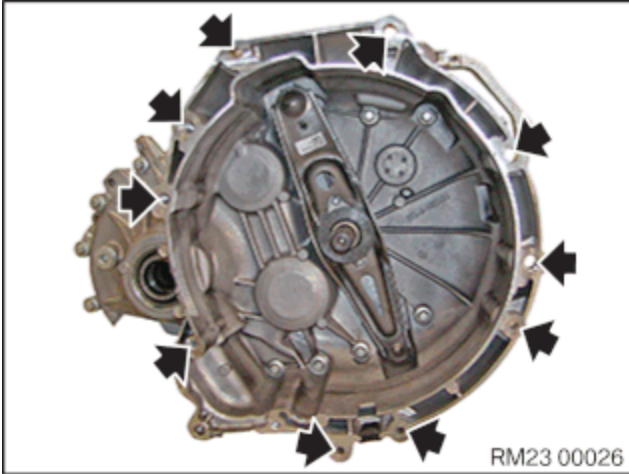

- Remove screws (arrows).
- Pull transmission downwards and remove.

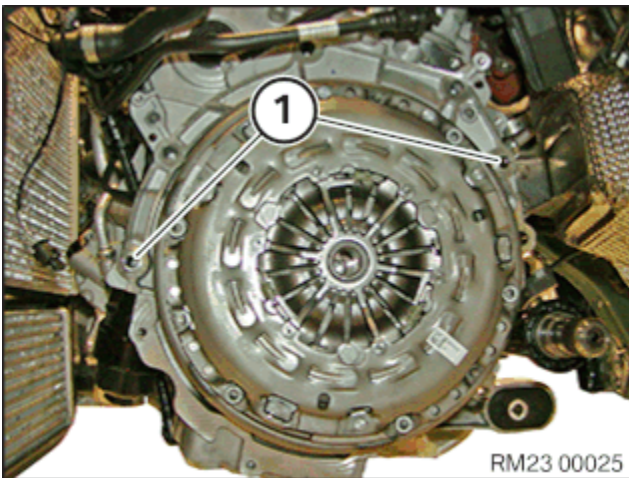

- Check for correct fit of fitting sleeves(1).
- Replace damaged fitting sleeves.

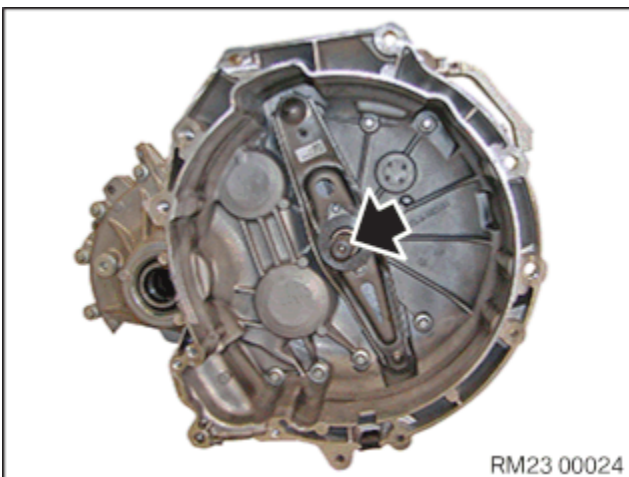

- Remove any grease from the transmission input shaft (arrow) and clean the shaft.
- Do not grease transmission input shaft.
- Check the clutch disc for frictional corrosion in the gearing and renew if necessary.

### 33 – Installing the manual gearbox (GS6-59DG, GS6X60DA)



### Materials harmful to health.

### Contact with fluids harmful to health!

- Note and follow safety information on containers.
- Conduct all work in appropriate personal protective equipment only.



### Damage to the engine block.

### Serious damage to the engine block and transmission due to damaged and corroded bolts.

- It is imperative that protruding threads of the transmission bolts are checked for corrosion and damage prior to removal.
- It is imperative that all rust is removed from corroded threads and that they are cleaned prior to removal.
- Renew rusted and damaged bolts.

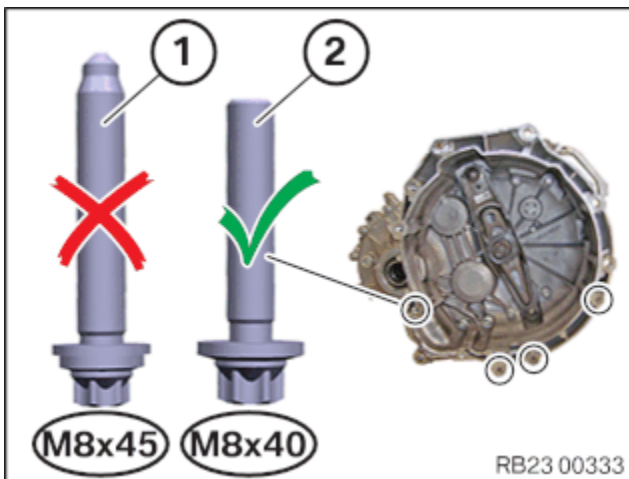

### Component damage caused by incorrect screw length.

### The use of screws with the incorrect screw length can damage the component.

- Check for correct screw length.
- Re-install screws that correspond to the original screw length.

- **Wrong:** The screw (1) (starter motor screw connection) must **not** be used for the bottom screw connection of the transmission.
- **Correct:** It is imperative to use the bolt (2) (M8x40) for the lower screw connection of the transmission and flange-mount the transmission.
- Tighten screws (arrows).

### Transmission to engine

M8x40	Tightening torque	19 Nm
M12x75	Tightening torque	66 Nm

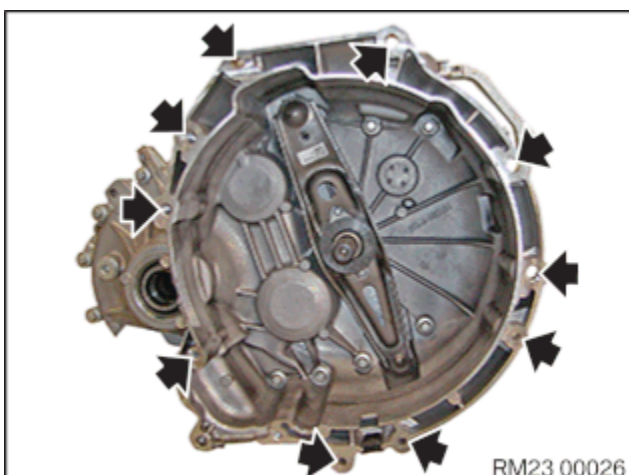

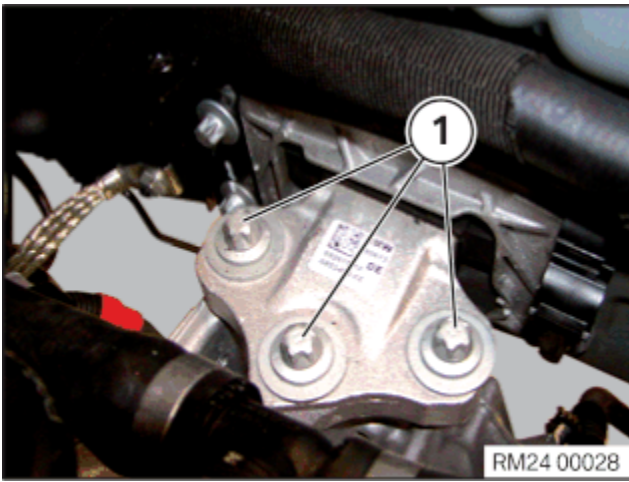

- Renew screws (1).

**Parts:** Bolts

- Tighten the screws (1).

#### Transmission mounting

M10	Renew screws.	Jointing torque	40 Nm
		Angle of rotation	90 °

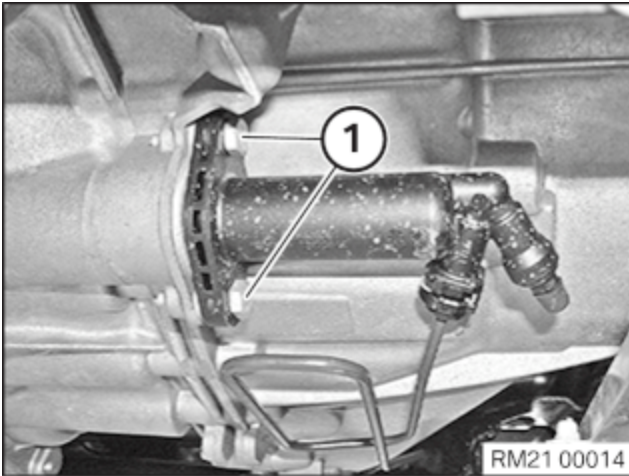

- Install clutch slave cylinder.
- Tighten the screws (1).

#### Clutch slave cylinder to transmission housing

M8		Tightening torque	19 Nm
----	--	-------------------	-------

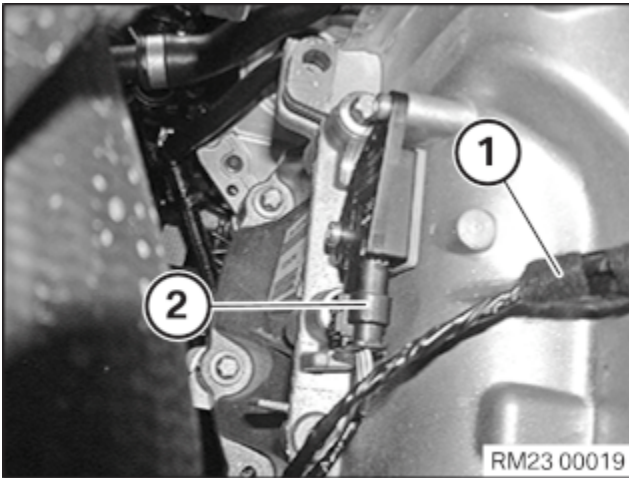

- Connect the plug connection (2) of the gear sensor.
- Clamp the cable (1) with the holder to the transmission.

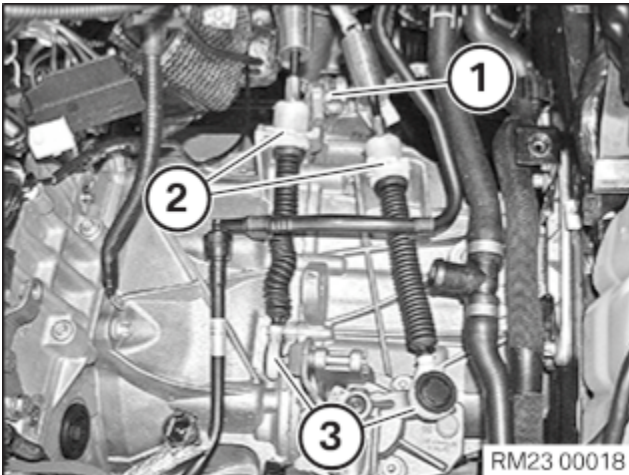

- Tighten the ground strap on the transmission with the screw (1).
- Clip in the clip on the stop/holder (2).
- Attach the selector lever cables (3) on the ball joints.

► **Install the battery holder**

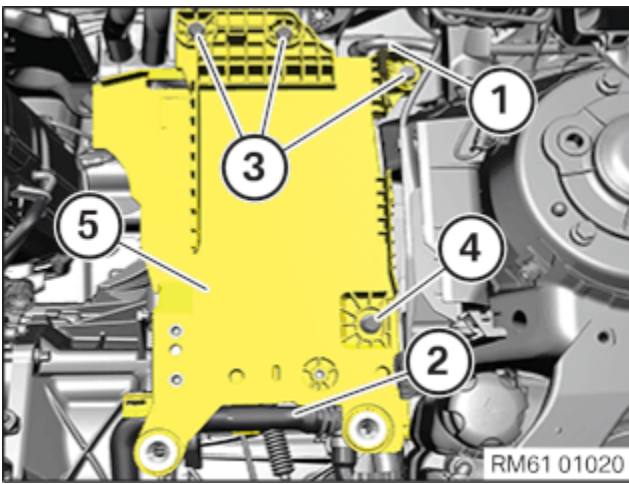

- Feed in and install the battery holder (5).
- Hand-tighten the bolt (4).
- Hand-tighten the bolts (3).
- Tighten down screw (4).

#### **Battery holder to engine support**

Hexagon screw M8x30	Tightening torque	19 Nm
------------------------	-------------------	-------

- Tighten down screws (3).

#### **Battery holder to engine support**

Hexagon screw M8x30	Tightening torque	19 Nm
------------------------	-------------------	-------

- Fasten the coolant line (2) on the battery holder (5).
- Fasten the cable clip (1) on the battery holder (5).

#### **► Installing the system battery partially**

- Install system battery (4).
- Correctly position the holder (3).
- Tighten down screw (2).

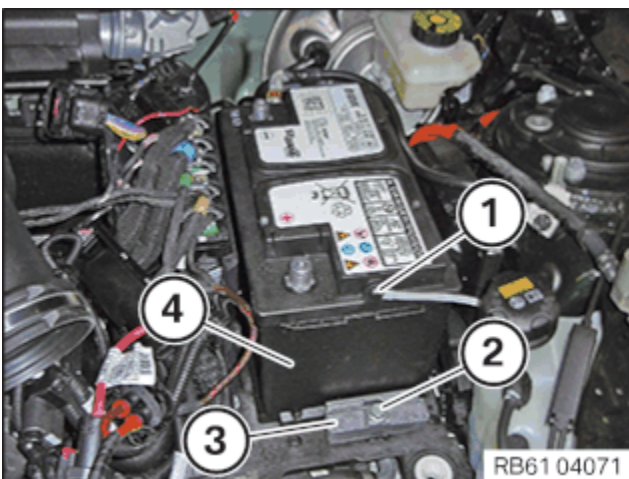

#### **Battery terminal rail to battery tray**

M8		19 Nm
----	--	-------

#### **Battery terminal rail to battery tray**

M8 screw	Tightening torque	15 Nm
----------	-------------------	-------

- Fit and clip the vent hose (1) in.

#### **▷ Check the vent holes of the battery**



#### **Gas emission.**

#### **Danger of injury! Danger of explosion!**

- Assign the vent holes correctly.
- Route the vent hose correctly.

# i

The battery has two vent holes, opposite:

One vent hole (1) must be closed correctly with a dummy plug.

The vent hose (3) must be correctly connected and routed at the other vent hole (2).

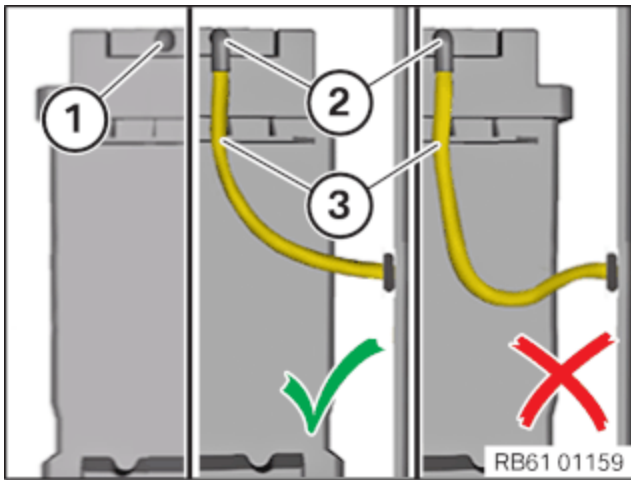

## Check

- Check if the vent hole (1) is correctly closed with a dummy plug.

## Result

No dummy plug.

## Measure

- Close the vent hole (1) correctly with a dummy plug.

## Check

- Check whether the vent hose (3) at the vent hole (2) has been connected correctly.

## Result

The vent hose (3) is not correctly connected.

## Measure

- Connect the vent hose (3) with the vent hole (2) correctly.

## Check

- Check whether the vent hose (3) is routed with a downhill gradient to the outside (**no siphon formation**).

## Result

The vent hose (3) is not routed correctly as shown at the right.

## Measure

- Route the vent hose (3) correctly as shown in the centre.



## ► Install electronics box

### Prerequisite

Battery earth lead is disconnected.



### Improper routing of cables and wiring harnesses.

Trapped, crushed or damaged cables may cause short circuits and malfunctions.

- Route all cables without abrasions, do not trap and crush.

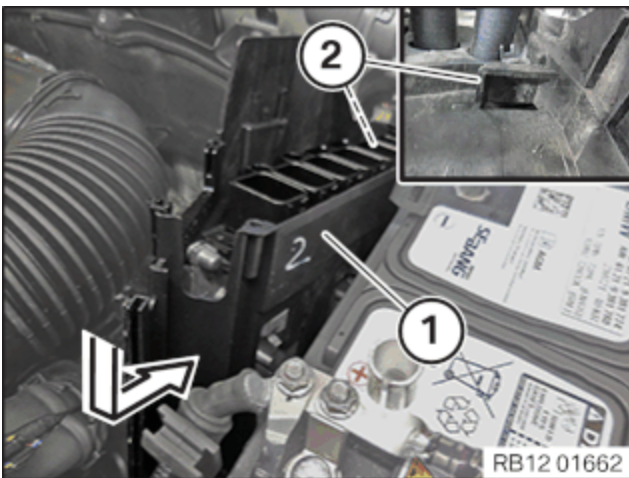

- Guide in and install the electronics box (1) into the guide (2) in direction of arrow.

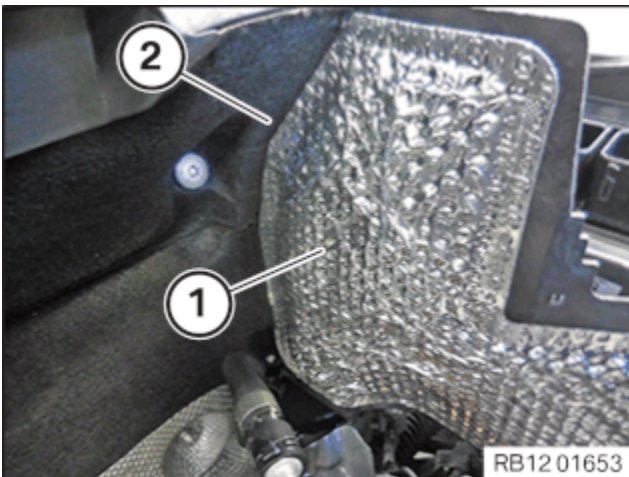

- Make sure that the electronics box (1) is positioned correctly on the bulkhead (2).

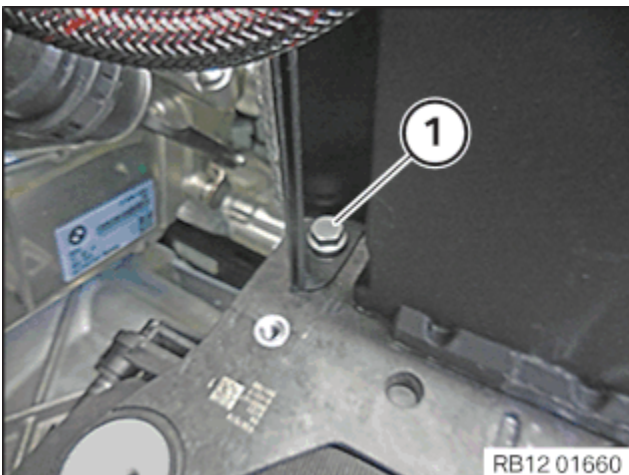

- Tighten down screw (1).

### Electronics box to battery tray

M8X16

Tightening  
torque

15 Nm

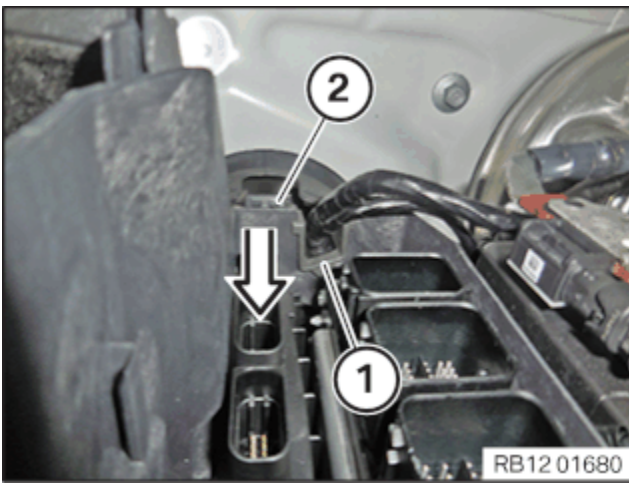

- Guide in and install the holder (1) in the electronics box (2) in direction of arrow.

The holder (1) must engage audibly.

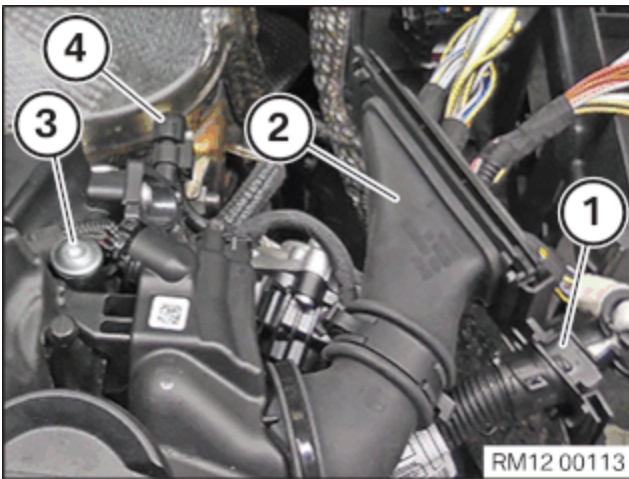

- Lay vehicle wiring harnesses (1) and (2) and mount on electronics box.
- Tighten down screw (3).

#### Wiring harness to cylinder head cover

TS5x20	Tightening torque	3,5 Nm
--------	-------------------	--------

- Connect the connector (4) to the differential pressure sensor and lock it audibly.

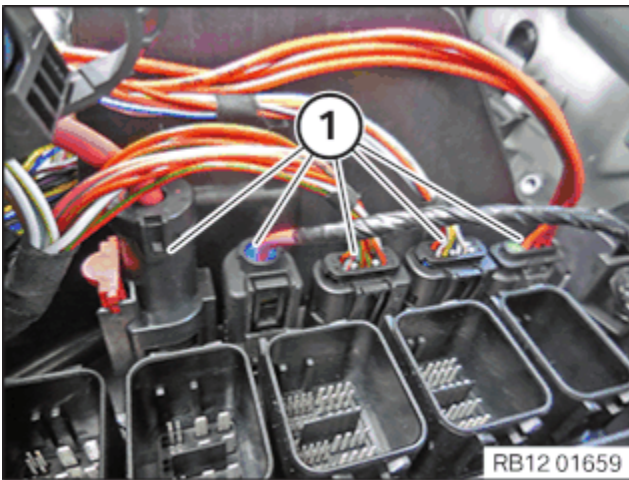

- Connect connectors (1) and lock. The connectors (1) must engage audibly.

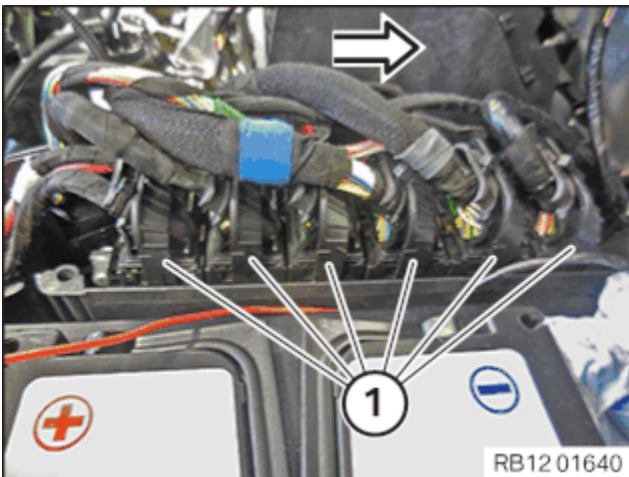

- Connect the connector (1) in the direction of arrow and lock it.

The connectors (1) must engage audibly.

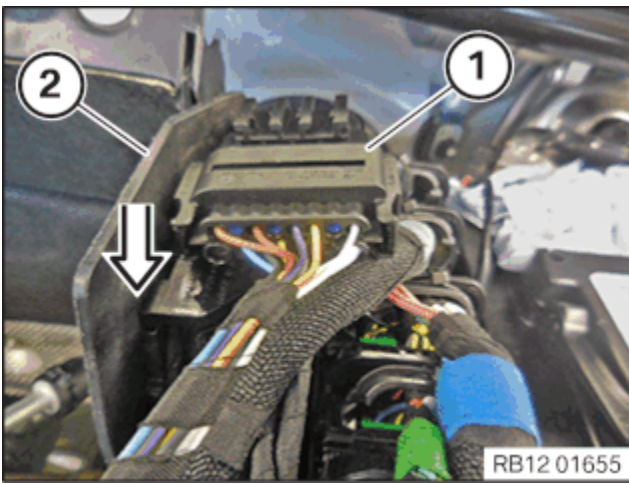

- Connect connectors (1) and lock.  
The connector (1) must engage audibly.
- Insert the connector (1) in the direction of arrow at the electronics box (2) and install.

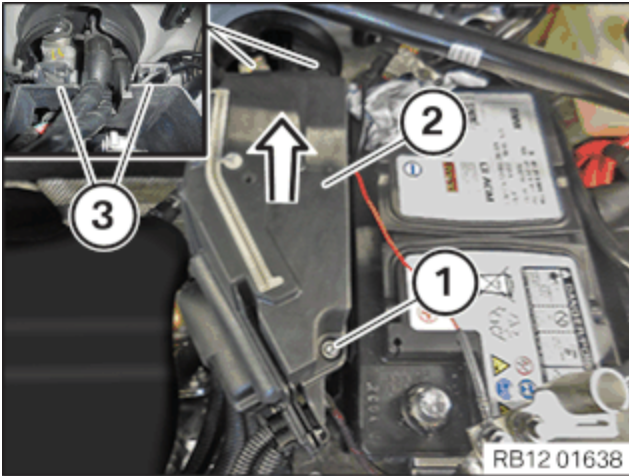

- Insert and install the cover (2) into the guides (3) in the direction of the arrow.  
The cover (2) must engage audibly in the guides (3).
- Tighten down screw (1).

#### Cover to electronics box

RF5x26.5	Tightening torque	2,5 Nm
----------	-------------------	--------

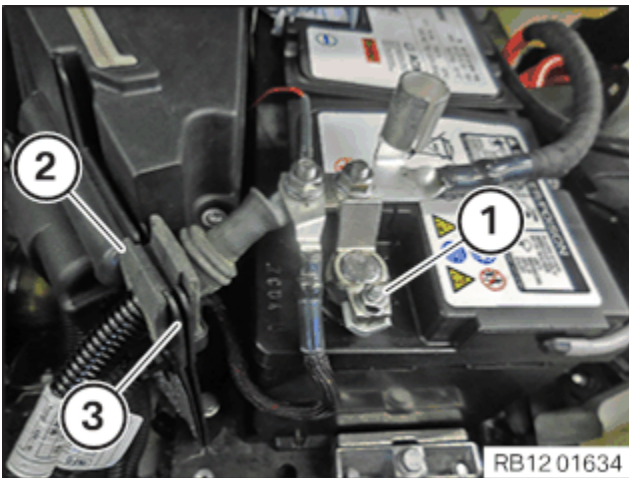

- Thread in positive battery cable (2) on holder (3) and install.
- Feed in and install positive battery terminal (1).
- Tighten positive battery terminal (1).

#### Positive battery terminal to battery

NutM6	Tightening torque	5 Nm
-------	-------------------	------

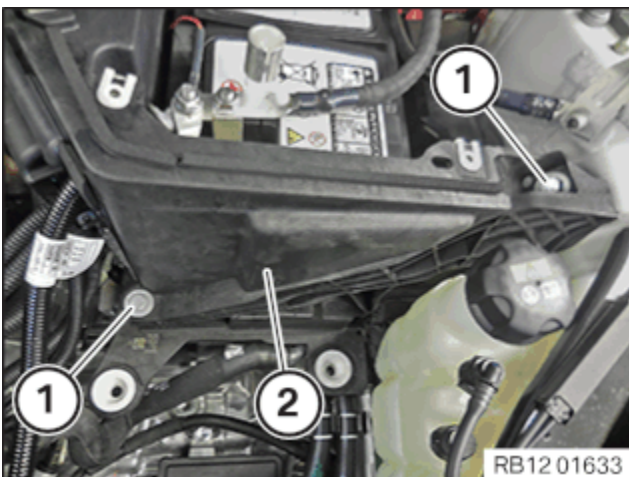

- Feed in and install tension strut (2).
- Tighten the screws (1).

#### Tension strut to spring strut dome/battery tray

M8	Tightening torque	19 Nm
----	-------------------	-------

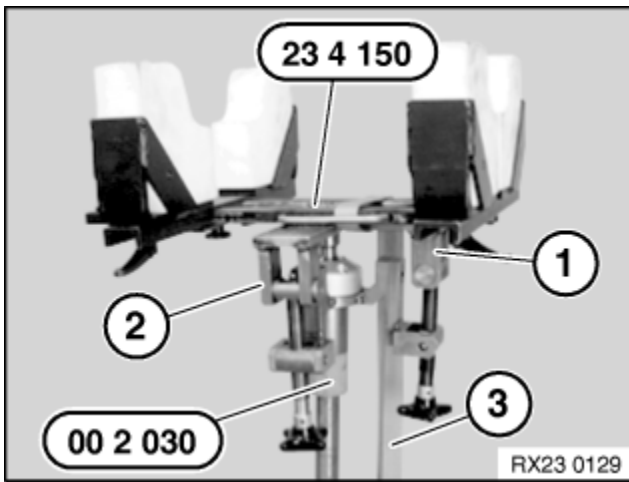

- Loosening the tensioning strap (3).
- Remove special tools **0 490 133 (00 2 030)** and .

## POSTPROCESSES

### 34 – Installing starter motor



**Improper routing of the positive battery cable.**

**Risk of short circuits!**

- Route the positive battery cable without abrasions and do not trap.

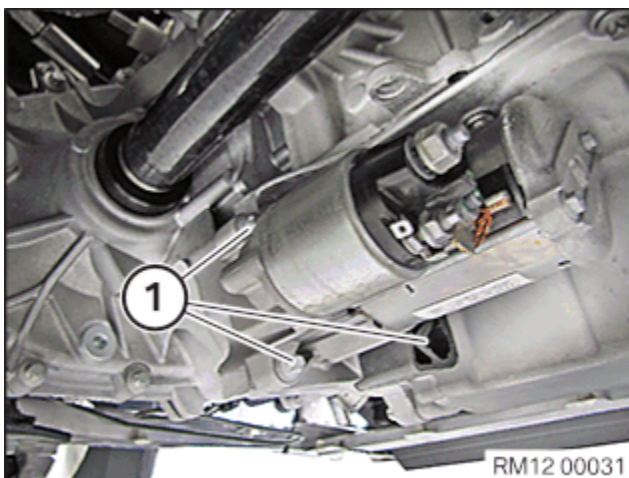

- Insert and install the starter motor .
- Tighten the screws (1).

#### **Starter motor to transmission**

M8x45	Tightening torque	19 Nm
-------	-------------------	-------

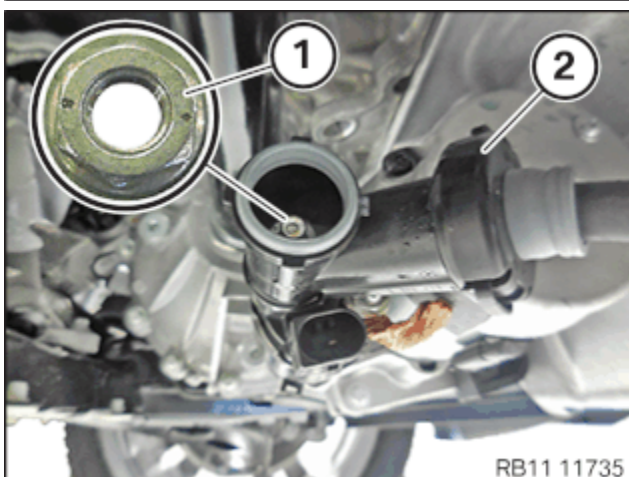

- Feed the positive battery cable (2) in on the starter and install.
- Tighten nut (1).

#### **Battery positive lead to starter**

M8	Tightening torque	13,5 Nm
----	-------------------	---------

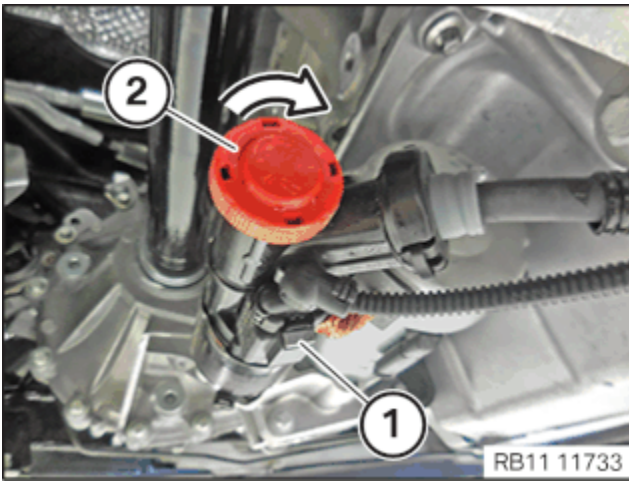

- Insert and install the new sealing cap (2).
- Secure the sealing cap (2) in the direction of the arrow.
- Connect and lock the connector (1).
- Make sure the connector (1) engages audibly.

### 35 – Installing right output shaft partially

#### ► Installing the radial shaft seal, right in the differential (manual gearbox)



**Materials harmful to health.**

**Contact with fluids harmful to health!**

- Note and follow safety information on containers.
- Conduct all work in appropriate personal protective equipment only.



**Damage to the transmission.**

**Damage to the transmission by unapproved transmission oil.**

- Use only the approved transmission oil.
- Check the transmission oil level after completing the repair.



- Coat sealing lips of radial shaft seal with transmission oil.
- Drive the radial shaft seal into the housing with the special tool until the sealing ring finishes flush with the transmission housing.

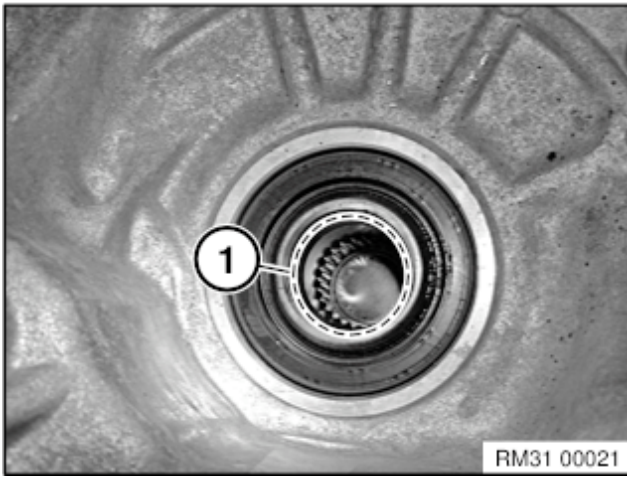

• **With automatic transmission only:**

- Lever out O-ring (1).
- Renew O-ring (1).

**Parts:** O-ring

- Insert new O-ring (1).

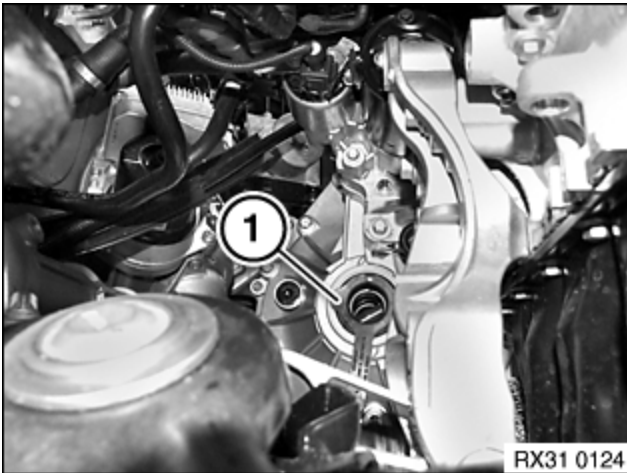

- Insert installation protection ring (1) into the radial shaft seal.
- Make sure the tool fits over the lip of the radial shaft seal so there is no damage to sealing ring when the output shaft is inserted.

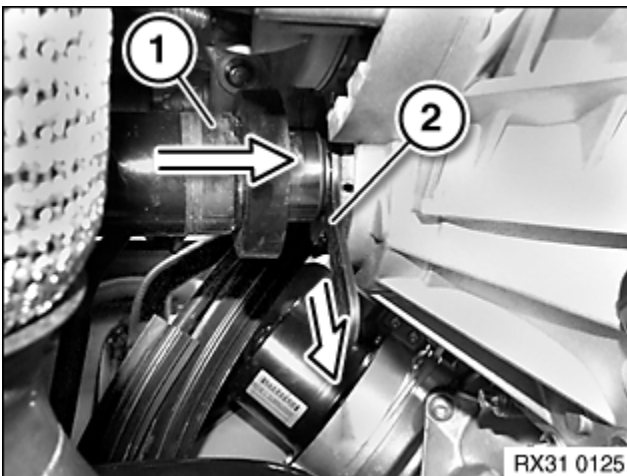

- Insert output shaft (1) into transmission.
- Pull on the handle to remove the installation protection ring (2) and dispose of it.
- Slide output shaft (1) into the transmission as far as the limit position.
- Check for secure seat by levering.

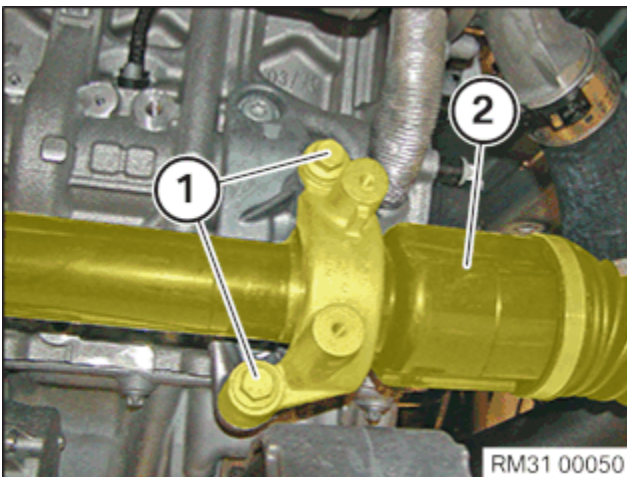

- Tighten the screws (1).

**Output shaft bearing to engine block**

M10

Tightening torque

38 Nm

## ► Installing the left radial shaft seal on the differential (manual gearbox)



**Materials harmful to health.**

**Contact with fluids harmful to health!**

- Note and follow safety information on containers.
- Conduct all work in appropriate personal protective equipment only.



**Damage to the transmission.**

**Damage to the transmission by unapproved transmission oil.**

- Use only the approved transmission oil.
- Check the transmission oil level after completing the repair.

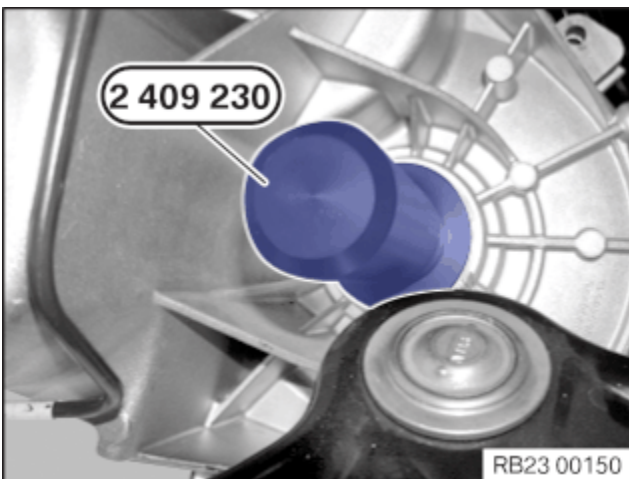

- Coat sealing lips of radial shaft seal with transmission oil.
- Drive the radial shaft seal into the housing with the special tool until the sealing ring finishes flush with the transmission housing.

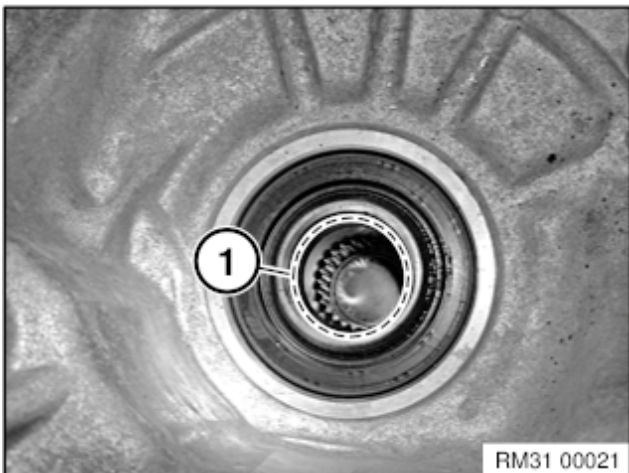

- **With automatic transmission only:**
  - Lever out O-ring (1).
  - Renew O-ring (1).
- Parts:** O-ring
- Insert new O-ring (1).

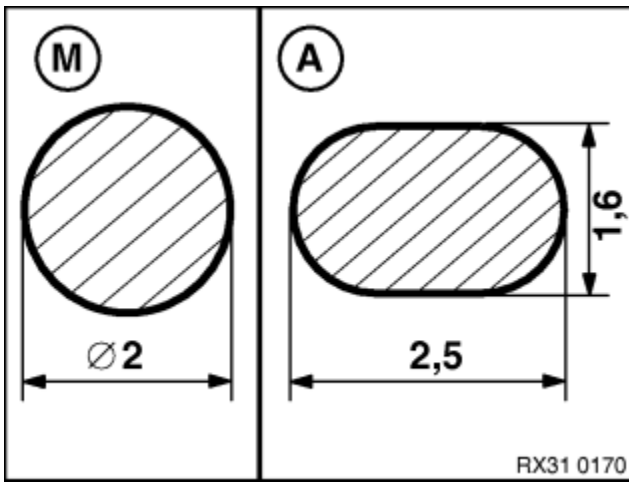

- Do not mix up circlips.

Different types of output shafts fitted:

**M:** Manual transmission

**A:** Automatic transmission

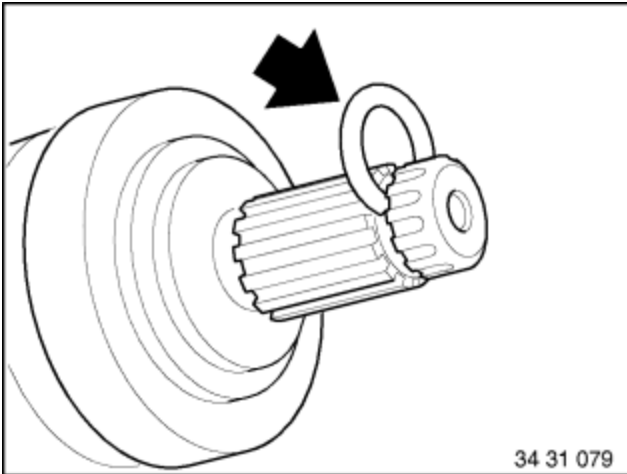

- Renew circlip (arrow).

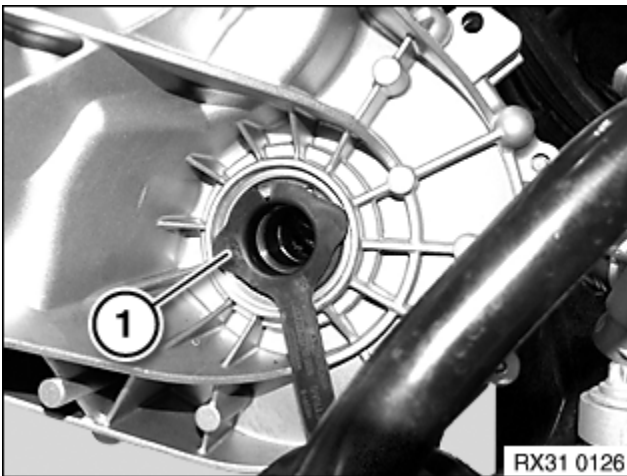

- Insert installation protection ring (1) into the radial shaft seal.
- Make sure the tool fits over the lip of the radial shaft seal so there is no damage to sealing ring when the output shaft is inserted.

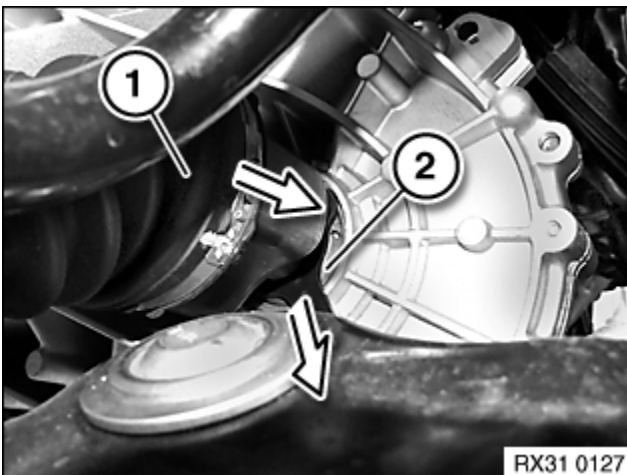

- Insert output shaft (1) into transmission.
- **Manual gearbox only:** Pull on the handle to remove the installation protection ring (2) and dispose of it.
- Slide output shaft (1) into the transmission as far as the limit position.  
The output shaft (1) must engage audibly.
- Check for secure seat by levering.

### 37 – Tighten down transmission-side bolting connection oil sump

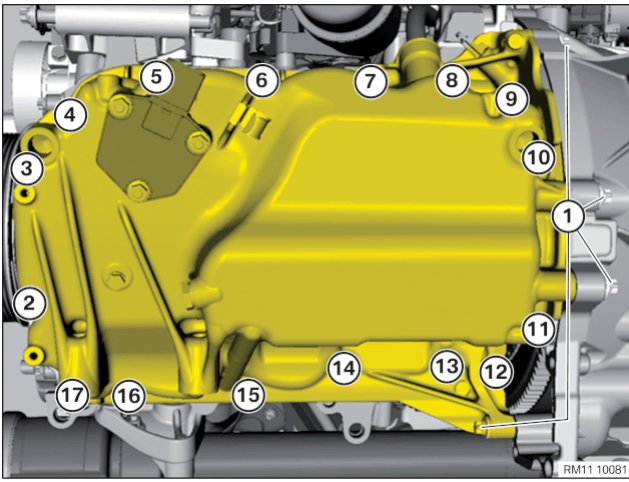

- Join transmission bolts (1) with 5 Nm.
- Tighten the transmission bolts (1) on the transmission.

#### Transmission to oil sump

M8

19 Nm

### 38 – Install front axle completely

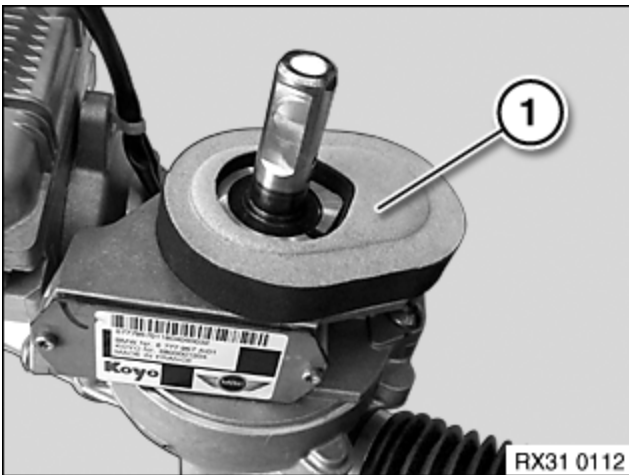

- Remove the seal (1).
- Clean surface on steering gear.
- Renew the gasket (1).

**Parts:** Gasket

- Position the seal (1) and glue it on.

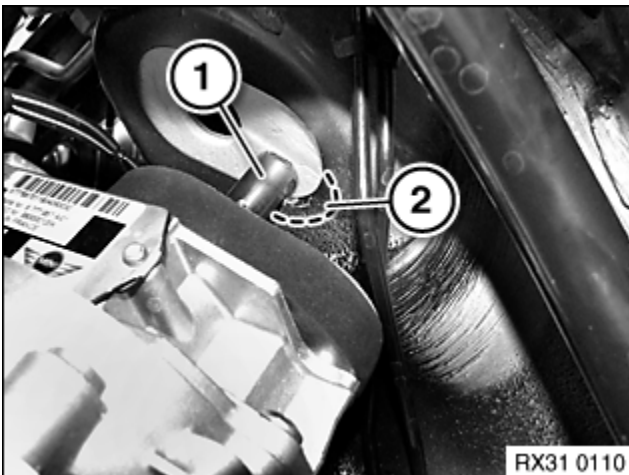

**Collision of the torsion bar of the EPS with the bulkhead.**

**Damage to the electromechanical steering gear (EPS)**

- When lowering and lifting the front axle support, ensure that the torsion bar of the electromechanical steering gear (EPS) does not collide with the bulkhead.
- Make sure the torsion bar (1) of the electromechanical steering gear (EPS) in the area (2) does not collide with the bulkhead.

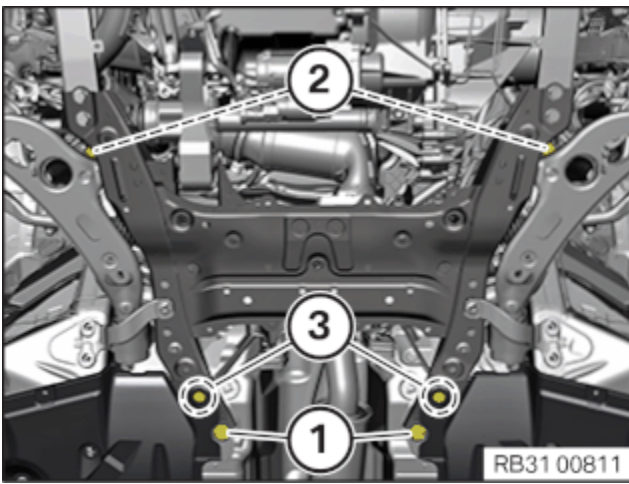

- Position the front axle completely with the universal jack.
- When lifting, feed the front axle support at the rear on the underbody panelling and the charge air cooler into the rubber mount of the charge air cooler.
- Lift the front axle completely with the universal jack.
- Renew screws (1) and (2).

**Parts:** Screws

- Tighten the screws (1).

#### **Rear end of front axle support to body**

M14 screw	Renew screw.	Tightening torque	175 Nm
-----------	--------------	-------------------	--------

- Tighten the screws (2).

#### **Front axle support, front to body**

M12 screw	Renew screw.	Tightening torque	108 Nm
-----------	--------------	-------------------	--------

- Tighten the screws (3).

#### **Underbody panelling, side**

Hexagon screw	Tightening torque	2,6 Nm
---------------	-------------------	--------

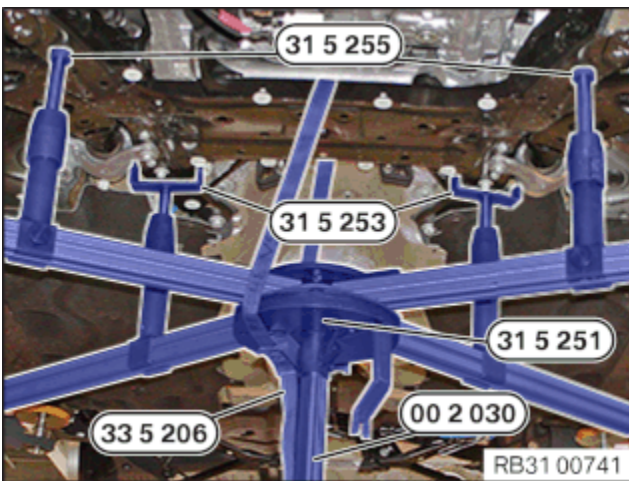

- Remove special tool from special tool .
- Lower the special tool **0 490 133 (00 2 030)** with the special tool and place it to the side.

### **39 – Securing the mounted part on the front axle support**

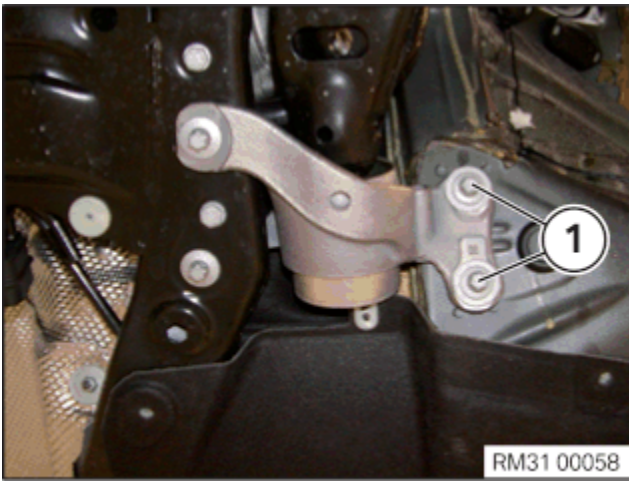

Perform the operations on the left and right side.

- Renew screws (1).

**Parts:** Screws

- Tighten the screws (1).

#### Holder, wishbone rubber mount, to body

M10 screw	Renew screw.	Jointing torque	56 Nm
		Angle of rotation	90 °

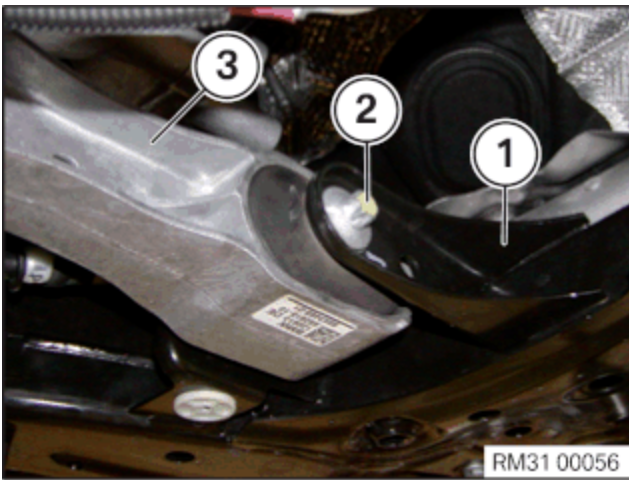

- Position the holder with rubber mount (3) on the front axle support (1).
- Tighten down screw (2).

#### Holder with rubber mount to front axle support

M12 screw			100 Nm
-----------	--	--	--------

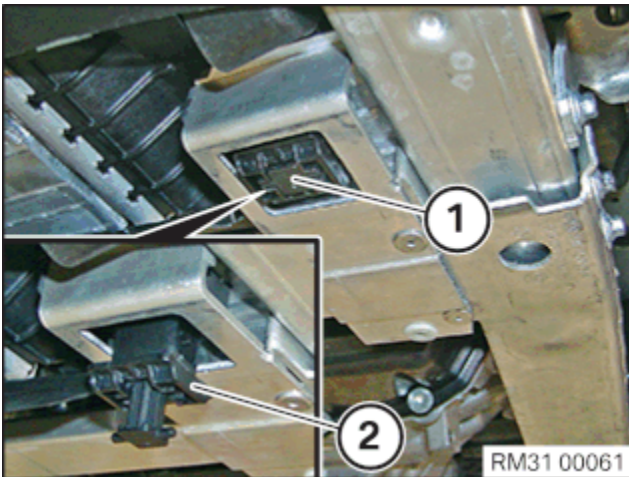

Perform the operations on the left and right side.

- Position lock (2).
- Lock safety catch (1) of the lock (2) from the holder for the charge air cooler.

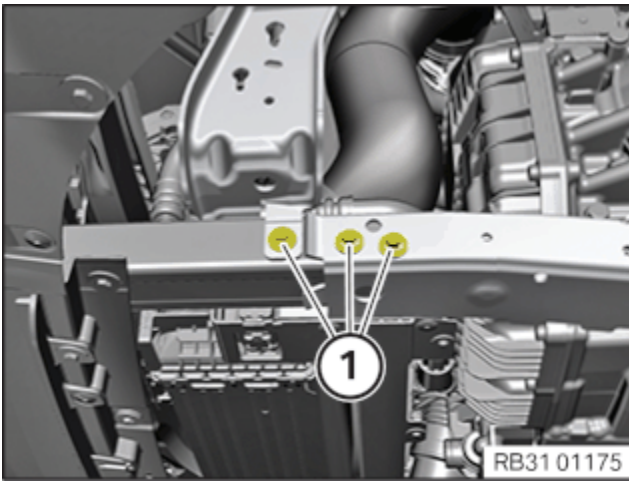

Perform the operations on the left and right side.

- Tighten the screws (1).

#### Deformation element, bottom, to adapter plate, front axle carrier

Screw	Tightening torque	11,8 Nm
-------	-------------------	---------

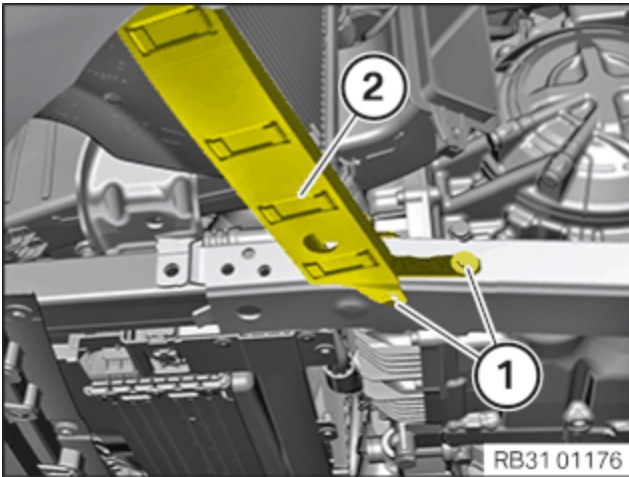

Perform the operations on the left and right side.



The following work step(s) is / are to be carried out if the specified component(s) is/are fitted.

- Feed in and position the holder (2) for the external radiator.
- Tighten the screws (1).

#### Holder for external radiator on deformation element

M6 screw	Tightening torque	8 Nm
----------	-------------------	------

## 40 – Securing the track rod on the left and right to the swivel bearing



Perform the operations on the left and right side.

### ► Securing the track rod on the swivel bearing

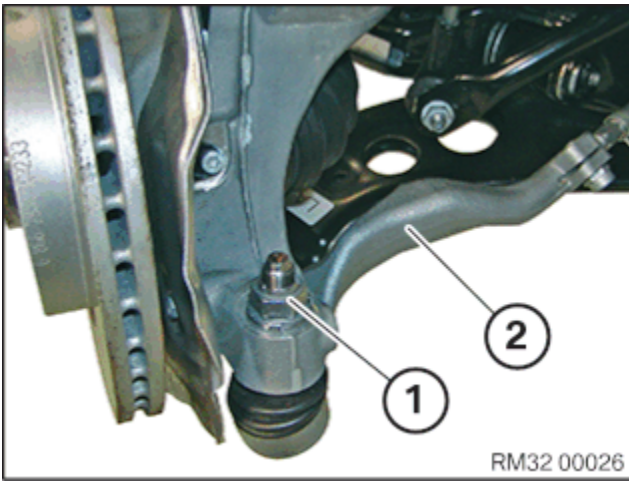

- Position the track rod (2) on the swivel bearing .
  - Renew nut (1).
- Parts:** Nut
- Tighten nut (1).

#### Track rod end to swivel bearing

M14	Renew nut.	Tightening torque	175 Nm
-----	------------	-------------------	--------

## 41 – Secure left and right wishbone onto swivel bearing



Perform the operations on the left and right side.

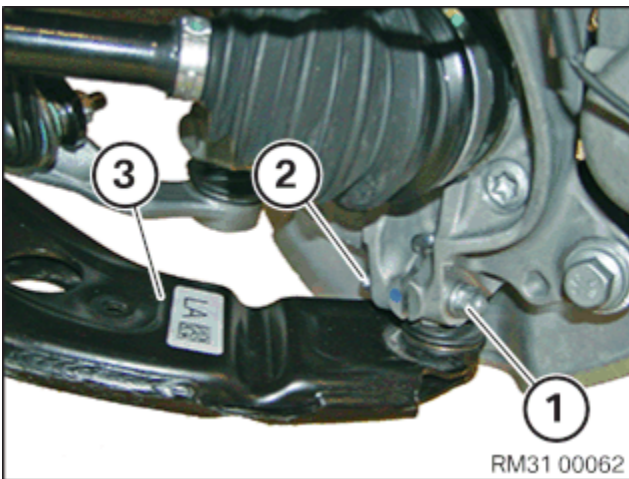

#### ► Fastening wishbone to swivel bearing

- Position the wishbone (3) on the swivel bearing .
  - Renew screw (2) and nut (1).
- Parts:** Bolt, nut
- Insert screw (2).
  - Fit the nut (1).
  - Tighten down screw (2).

#### Wishbone to swivel bearing

M10	Exclusively use the screw to tighten! Renew screw and nut.	Tightening torque	56 Nm
-----	---	-------------------	-------

## 42 – Attaching connector at steering gear

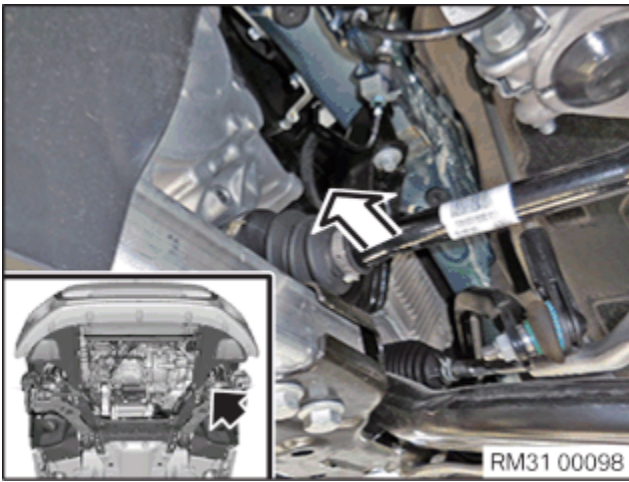

- To connect the connector (see the following step): Connect the connector with the right hand in the direction of arrow.

The connectors can be accessed via the left output shaft (arrow).

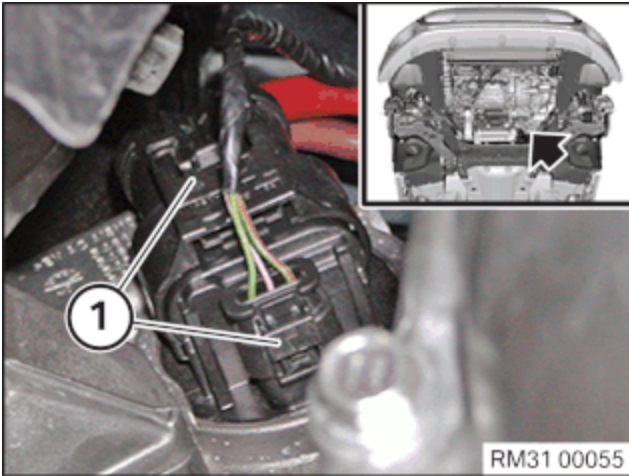

- Connect and lock connector (arrow) (1) with the steering gear.

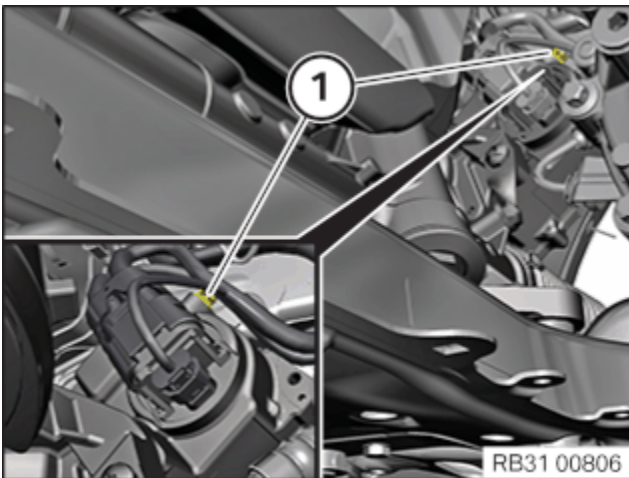

- Fasten the wiring harness (1) on the steering gear.

### 43 – Securing rubber mount on front axle support

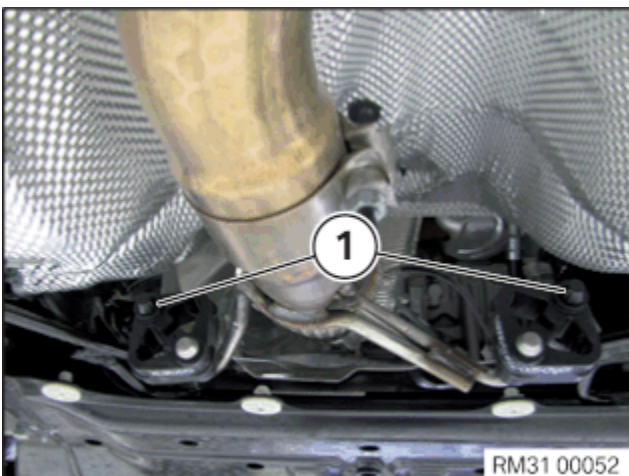

- Check the rubber mount (1) for damage and renew, if necessary.
- Spray rubber mount (1) with lubricant and slide onto holder on front axle support.

## 44 – Securing anti-roll bar on left and right on the anti-roll bar link



Perform the operations on the left and right side.

### ► Fastening anti-roll bar on the anti-roll bar link

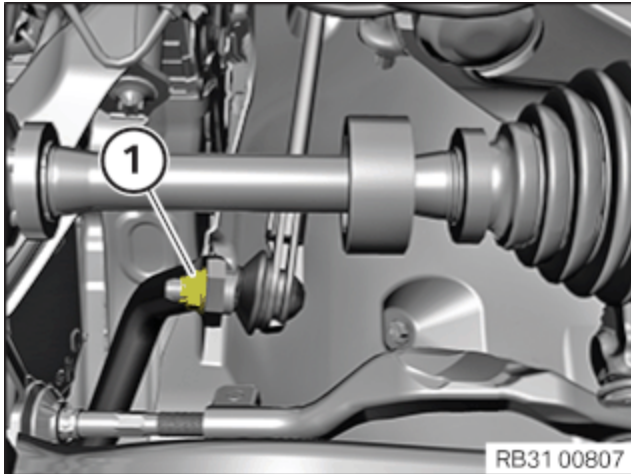

- Position the anti-roll bar link on the anti-roll bar .
- Renew nut (1).

**Parts:** Nut

- Tighten nut (1).

**Note** Use the Torx socket for counter support.

### Anti-roll bar link to anti-roll bar/spring strut

M10	Renew nut.	Tightening torque	56 Nm
-----	------------	-------------------	-------

## 45 – With right installation: Securing the cable for the ride height sensor

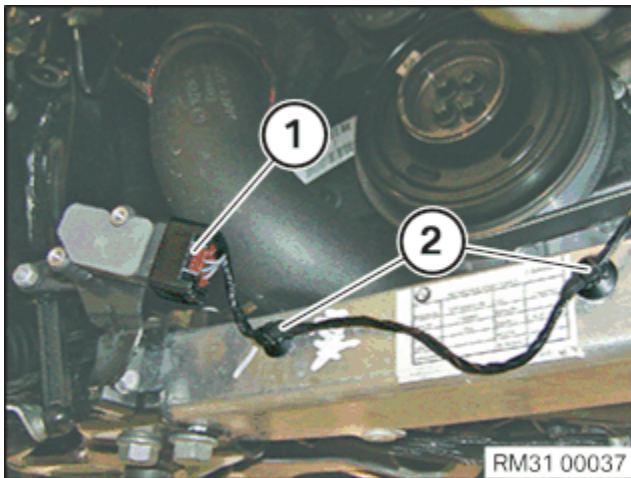

- Secure the cable clip (2) on the adapter of the deformation element.
- Connect connectors (1) and lock.

## 46 – Installing front left and right wheel arch cover



Perform the operations on the left and right side.

### ► Installing the front wheel arch cover



To provide a better overview: Schematic diagram with partially hidden components.

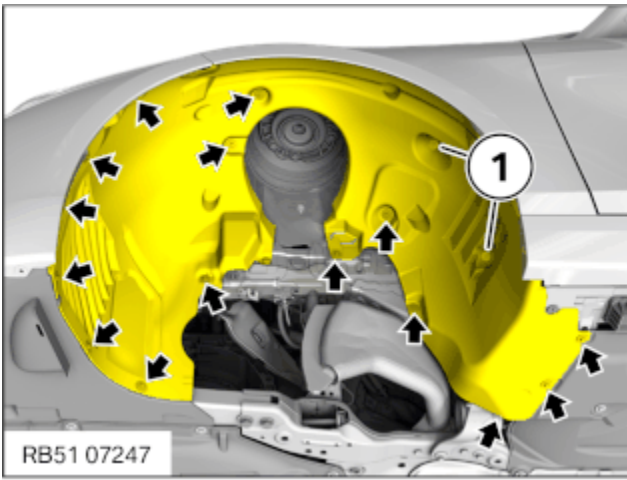

- Guide the front wheel arch cover in.
- Tighten screws (arrows).

#### Wheel arch cover to body

Hexagon screw	Tightening torque	2,6 Nm
---------------	-------------------	--------

- Tighten nuts (1).

#### Wheel arch cover to body

Plastic nut	Tightening torque	2,6 Nm
-------------	-------------------	--------

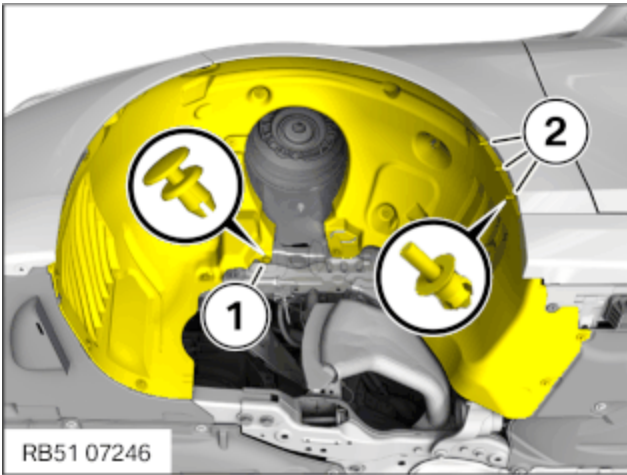

- Secure expanding rivet (2).
- Fasten expanding rivet (1).

#### ► If installed: Mount brake air duct



To provide a better overview: Schematic diagram with partially hidden components.



- Tighten the screws (1).

#### Wheel arch cover to brake air duct

Hexagon screw	Tightening torque	2,6 Nm
---------------	-------------------	--------

### 47 – Installing the front left and right bottom cover



Description is for left component only. Procedure on the right side is identical.

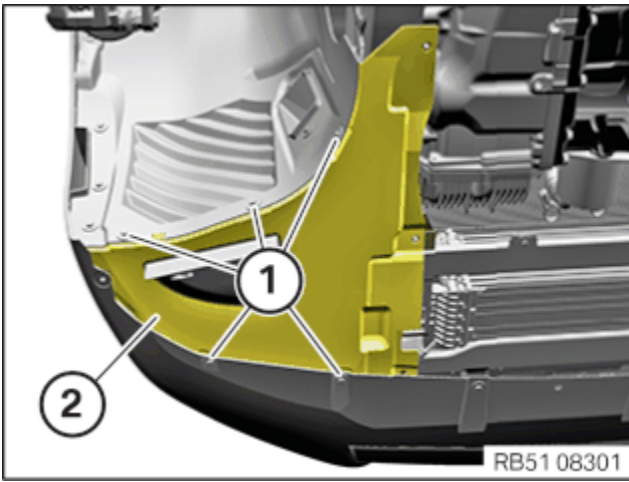

- Insert and install the cover (2).
- Tighten the screws (1).

#### Front bottom cover at the side to front bumper panel

Hexagon screw for thermoplastic

Tightening torque

3 Nm

## 48 – Mounting the front left and right wheels



Perform the operations on the left and right side.

### ► Mounting the wheel

#### ▷ Clean the contact surfaces between the brake disc and the wheel rim

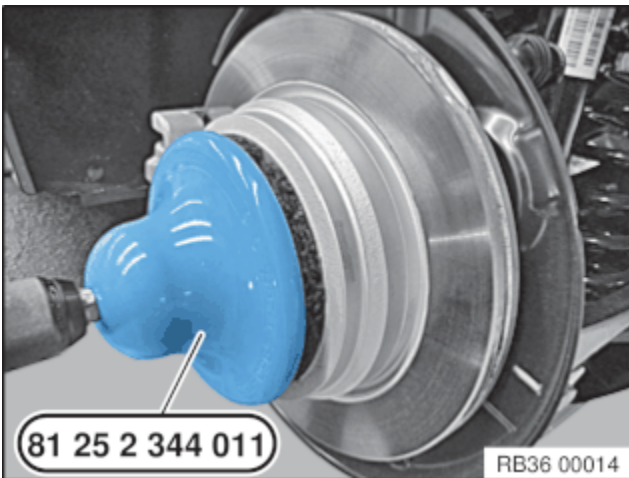

The contact surface between the brake disc and the wheel rim must be clean and free from oil and grease. There is otherwise a risk of the wheel becoming loose at a later time.

- Remove dirt, grease residues and corrosion from the contact surface with a drill and the special tool **2 344 011**.

Do not operate special tool **2 344 011** with an impact screwdriver.

- Degrease the contact surfaces with the universal cleaner (see BMW Group Parts).
- If there are grease deposits in the area of the wheel bolt holes, remove and clean the brake disc.

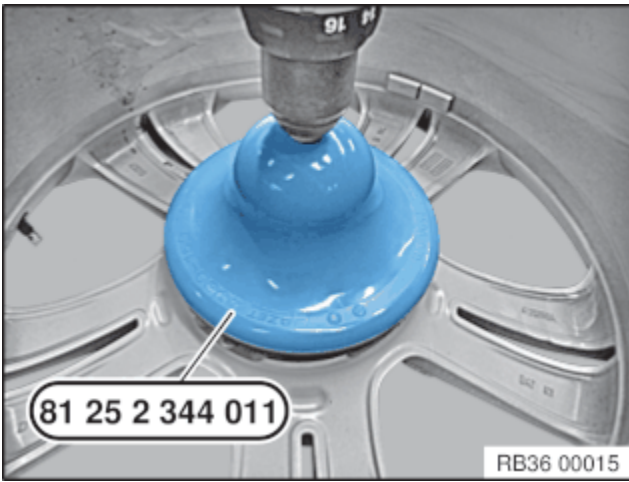

- Remove dirt, grease residues and corrosion from the contact surface with a drill and the special tool **2 344 011**.

Do not operate special tool **2 344 011** with an impact screwdriver.

- Degrease the contact surfaces with the universal cleaner (see BMW Group Parts).

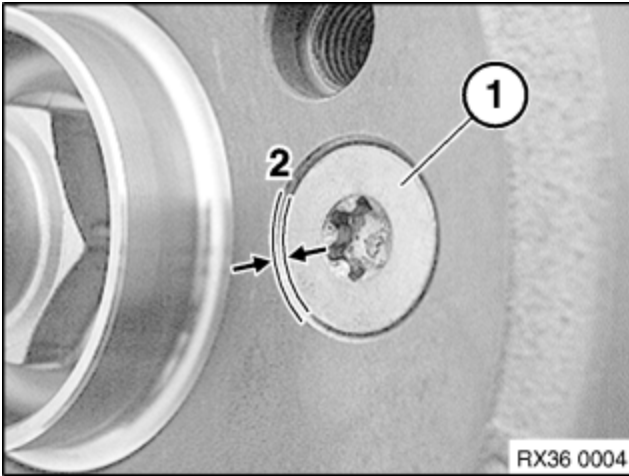

- Check that the mounting bolt (1) for the brake disc is securely seated.

The mounting bolt (1) for the brake disc **may not** protrude on the contact surface (2) between the brake disc and the wheel rim.

#### **Brake disc to front wheel hub**

M8	Tightening torque	16 Nm
----	-------------------	-------

#### **Brake disc to rear wheel hub**

M8	Tightening torque	16 Nm
----	-------------------	-------

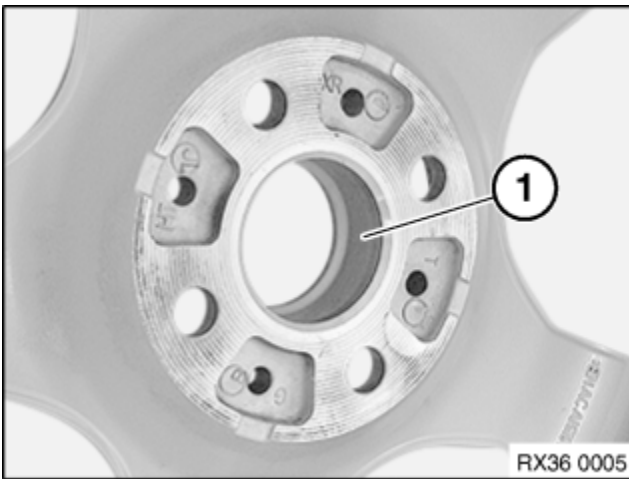

- Thinly grease the wheel centring (1) in the wheel rim.

For the grease for the wheel centring (1) see further information.

◁

**Check**

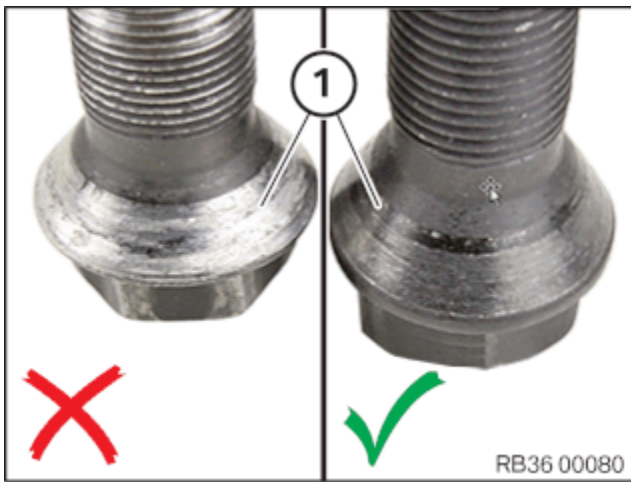

- Check wheel bolts for wear.

### Result

Spots (> 30%) of the bearing surface (1) of the taper on the screw head show silvery wear.

### Measure

- Replace wheel bolts.

**Parts:** Wheel bolts



Never use impact screwdrivers or electric screwdrivers to screw in and tighten the wheel bolts.

The wheel rim must rest uniformly against the brake disc.

In the case of non-original BMW wheel bolts/wheel rims, it may be necessary to retighten the wheel bolts on account of setting properties (refer to the documentation from the manufacturer).

Do not apply oil to new wheel bolts.

- Renew the corroded wheel bolts (arrows).

**Parts:** Wheel bolts

- Clean the wheel bolts (arrows).
- Check wheel bolts (arrows) and threads for damage, renew the wheel bolts if necessary.
- Join and tighten the wheel bolts (arrows).

#### Wheel bolts

M 14/AF 17	Screw in wheel bolts and evenly tighten crosswise by hand in order to centre the wheel rim.	Tightening torque	140 Nm
	Tighten wheel bolts to the prescribed tightening torque with a calibrated torque wrench in a crosswise sequence.	Check	140 Nm
	Check all the wheel bolts in the same order or retighten to the prescribed tightening torque again.		

## 49 – Removing the mounting of the coolant radiator on the left and right

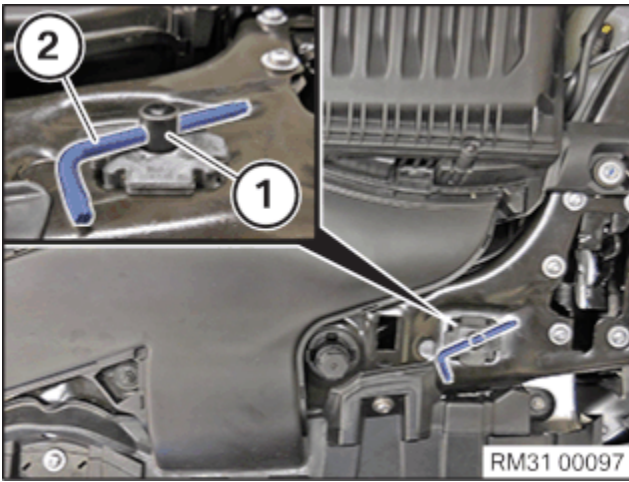

Perform the operations on the left and right side.

- Remove suitable tool (2) from the centering pin (1).

## 50 – Securing the steering shaft at the bottom on the steering gear

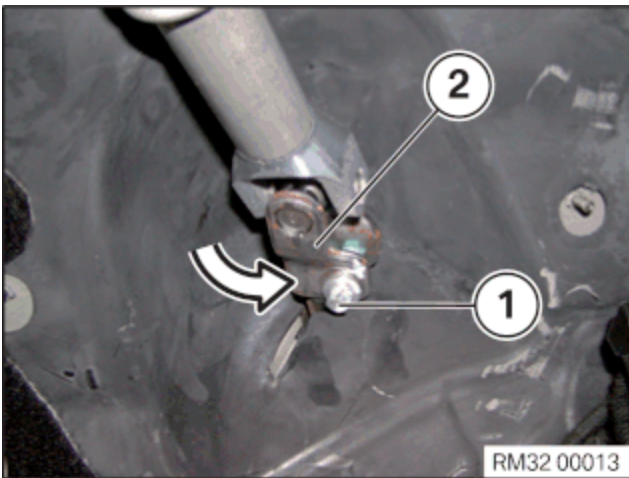

- Clean the screw thread in the universal joint (2) from the residues of screw locking agent.
- Pivot the universal joint (2) in the direction of the arrow to the steering gear.
- Renew the screw (1).

**Parts:** Screw

- Tighten down screw (1).

### Lower steering shaft to steering gear

M10	Clean screw thread and remove remains of screw locking agent. Renew screw.	Tightening torque	28 Nm
-----	---	-------------------	-------

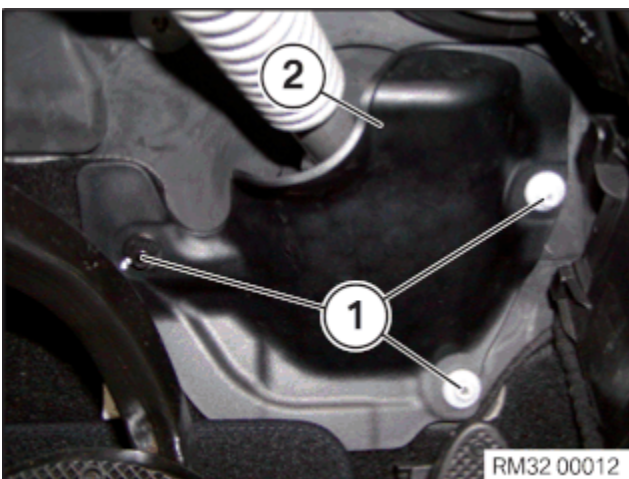

The following work step(s) is / are to be carried out if the specified component(s) is/are fitted.

- Position the cover (2) on the steering column.
- Tighten nuts (1).

### Steering column cover to bulkhead

Plastic nut		Tightening torque	3 Nm
-------------	--	-------------------	------

## 51 – Installing underbody protection at rear

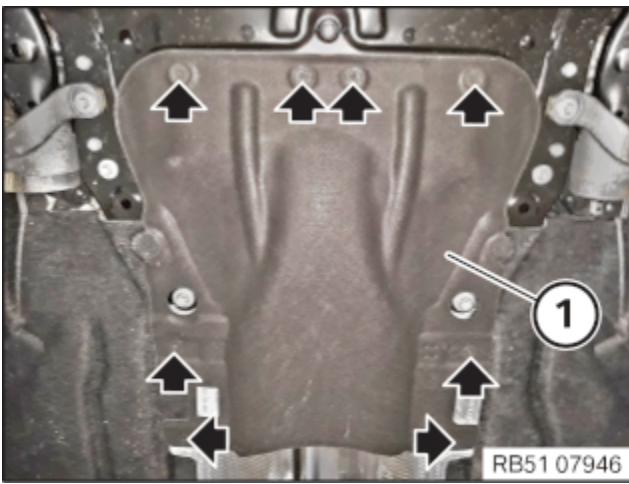

- Position rear underbody protection (1) .
- Tighten screws (arrows).

#### Underbody protection to body

Screw	Tightening torque	2.5 Nm
-------	-------------------	--------

## 52 – Installing the front underbody protection

**i**

Different variants may be installed depending on the vehicle equipment.

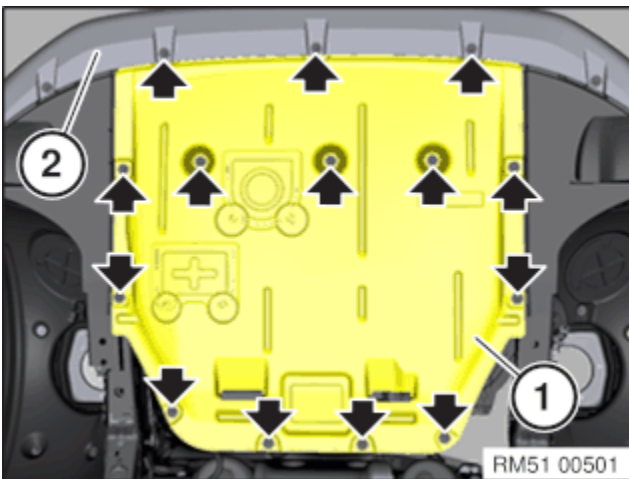

- **Version A:**  
Guide in the front underbody protection (1) at the bumper panel(2) and position.
- Tighten screws (arrows).

#### Underbody protection to body

Screw	Tightening torque	2.5 Nm
-------	-------------------	--------

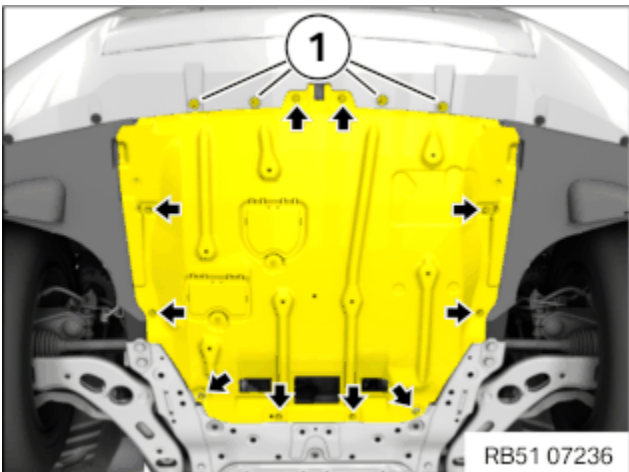

- **Version B (S8SDA):**  
Guide in the front underbody protection at the bumper panel and position it.
- Tighten screws (arrows).

#### Front underbody protection on body/front axle support

M6x20 screw	Tightening torque	8 Nm
-------------	-------------------	------

- Tighten the screws (1).

#### Underbody protection to body

Screw	Tightening torque	2.5 Nm
-------	-------------------	--------

### ► Installing the front right cross-member



Description is for left component only. Procedure on the right side is identical.

### ▷ Installing the front cross-member



The following work step(s) is / are to be carried out if the specified component(s) is/are fitted.

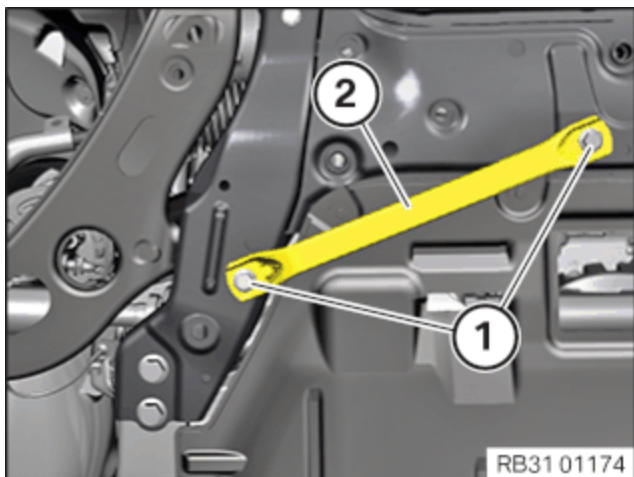

- Position the front cross-member (2).
- Renew screws (1).

#### Parts: Screws

- Position screws (1).
- Tighten the screws (1).

#### Cross-member on front axle support

M10x35	Renew screw.	Tightening torque	56 Nm
		Tightening torque	45 °



### 53 – Removing the mounting of the coolant radiator on the left and right

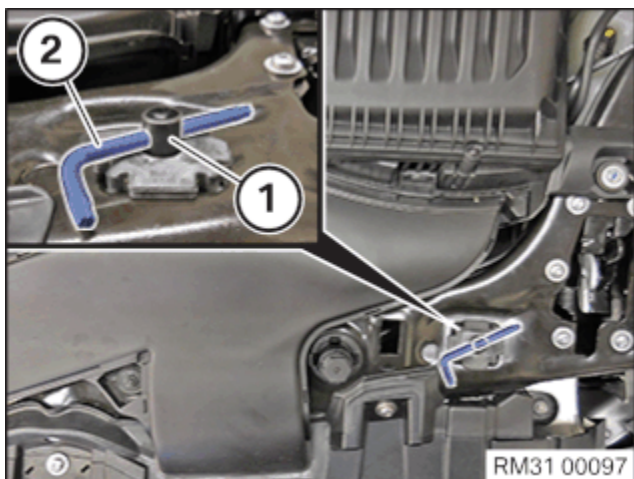

Perform the operations on the left and right side.

- Remove suitable tool (2) from the centering pin (1).

### 54 – Securing the steering shaft at the bottom on the steering gear

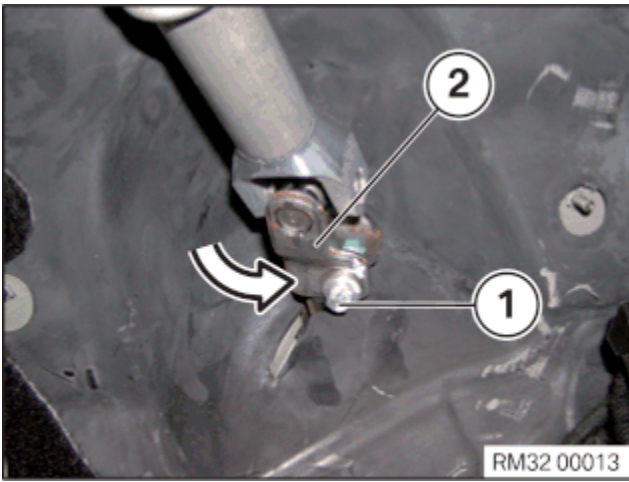

- Clean the screw thread in the universal joint (2) from the residues of screw locking agent.
- Pivot the universal joint (2) in the direction of the arrow to the steering gear.
- Renew the screw (1).

**Parts:** Screw

- Tighten down screw (1).

#### Lower steering shaft to steering gear

M10	Clean screw thread and remove remains of screw locking agent. Renew screw.	Tightening torque	28 Nm
-----	---	-------------------	-------

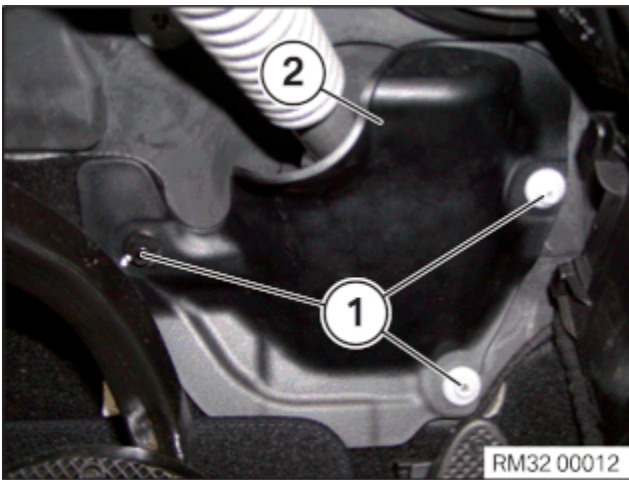

The following work step(s) is / are to be carried out if the specified component(s) is/are fitted.

- Position the cover (2) on the steering column.
- Tighten nuts (1).

#### Steering column cover to bulkhead

Plastic nut	Tightening torque	3 Nm
-------------	-------------------	------

## 55 – Installing system battery

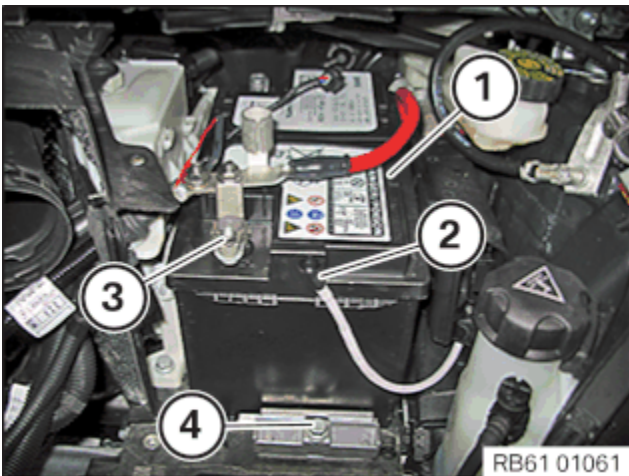

- Install system battery (1).
- Position the bracket and tighten with the screw (4) .

#### Battery terminal rail to battery tray

M8	19 Nm
----	-------

- Position the vent hose (2) and clip it in.
- Position the positive battery terminal and tighten with the nut (3) .

#### Battery terminal with IBS positive battery terminal / negative battery terminal

NutM6	5 Nm
-------	------

► Check the vent holes of the battery



## Gas emission.

### Danger of injury! Danger of explosion!

- Assign the vent holes correctly.
- Route the vent hose correctly.

## i

The battery has two vent holes, opposite:

One vent hole (1) must be closed correctly with a dummy plug.

The vent hose (3) must be correctly connected and routed at the other vent hole (2).

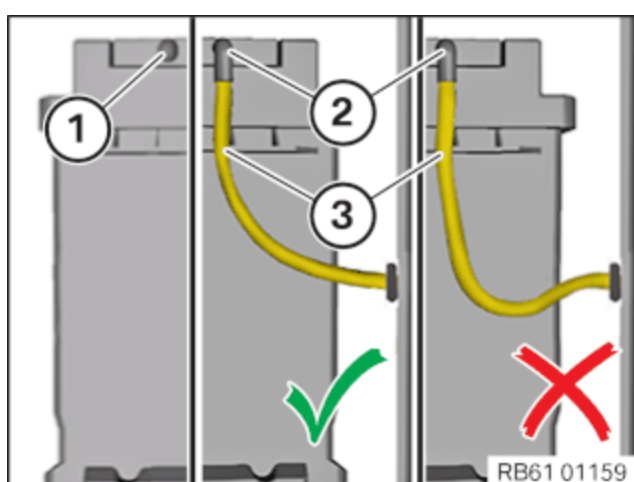

### Check

- Check if the vent hole (1) is correctly closed with a dummy plug.

### Result

No dummy plug.

### Measure

- Close the vent hole (1) correctly with a dummy plug.

### Check

- Check whether the vent hose (3) at the vent hole (2) has been connected correctly.

### Result

The vent hose (3) is not correctly connected.

### Measure

- Connect the vent hose (3) with the vent hole (2) correctly.

### Check

- Check whether the vent hose (3) is routed with a downhill gradient to the outside (**no siphon formation**).

## Result

The vent hose (3) is not routed correctly as shown at the right.

## Measure

- Route the vent hose (3) correctly as shown in the centre.
- Insert tension strut (3) and tighten with screws (1).

## Trailing link

M8	Tightening torque	19 Nm
----	-------------------	-------

- Tighten down screw (2).

## Battery cover

M8	2,8 Nm
----	--------

- Position the cover (2).
- Tighten down screw (1).

## Battery cover

M8	2,8 Nm
----	--------

- Position the fixture for the gasket (3) and secure with the expanding rivet (2).
- Tighten down screw (1).

## Battery cover

M8	2,8 Nm
----	--------

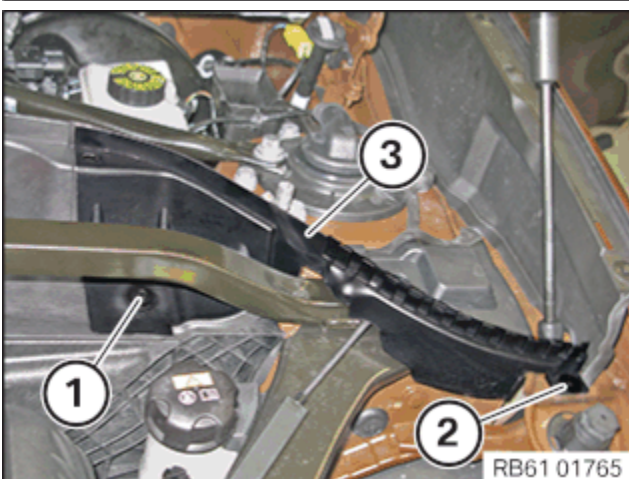
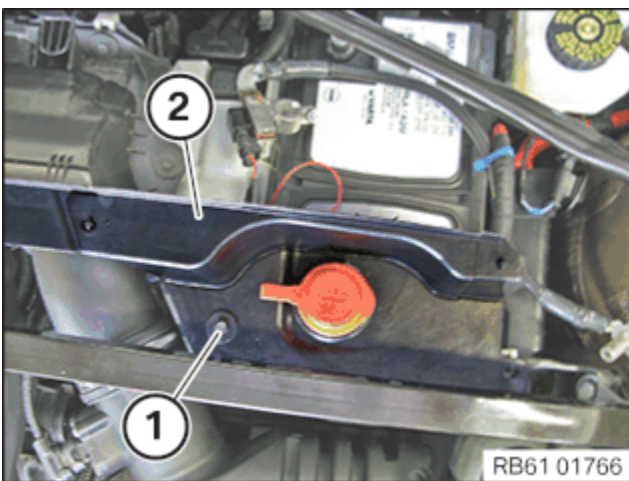
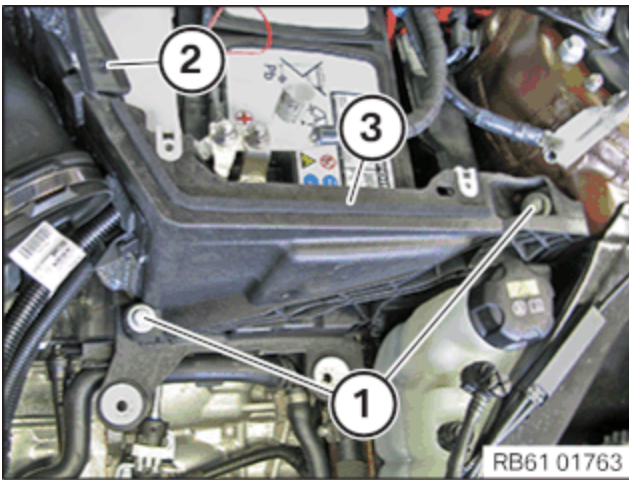

## 56 – Installing intake silencer housing

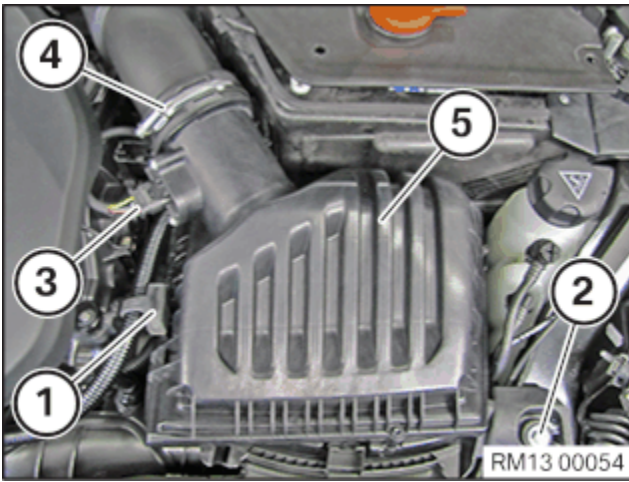

- Insert the intake silencer housing (5) into the rubber mounts and install it.

Intake filter housing (5) must engage audibly.

- Tighten down screw (2).

#### **Intake silencer housing to lock bridge**

M6X30	Tightening torque	8 Nm
-------	-------------------	------

- Tighten clamp (4).

#### **Clean air pipe to intake silencer housing**

Clamp	Tightening torque	3 Nm
-------	-------------------	------

- Connect and lock the connector (3).  
The connector (3) must engage audibly.
- Insert and install the holder (1).

### **57 – Install the intake neck for the intake filter housing**

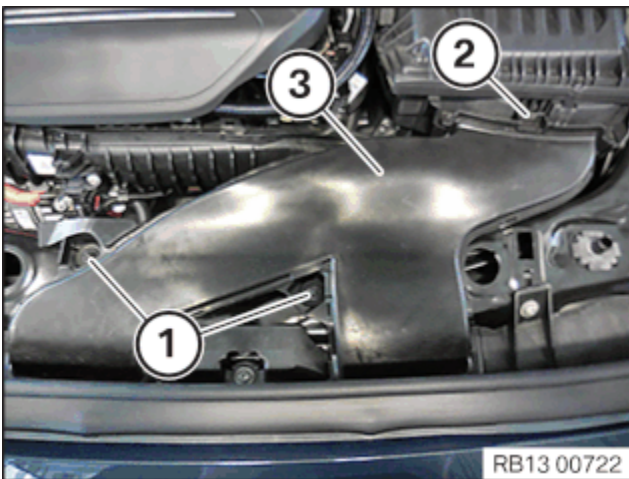

- Insert and install the intake neck (3).  
The lock (2) must audibly engage.
- Tighten nuts (1).

#### **Intake neck to cross connection**

M6	Tightening torque	8 Nm
----	-------------------	------

### **58 – Remove the engine bridge**



**Heavy component.**

**Heavy components can lead to injury or damage.**

- Remove and install heavy components with the aid of another person/other persons.

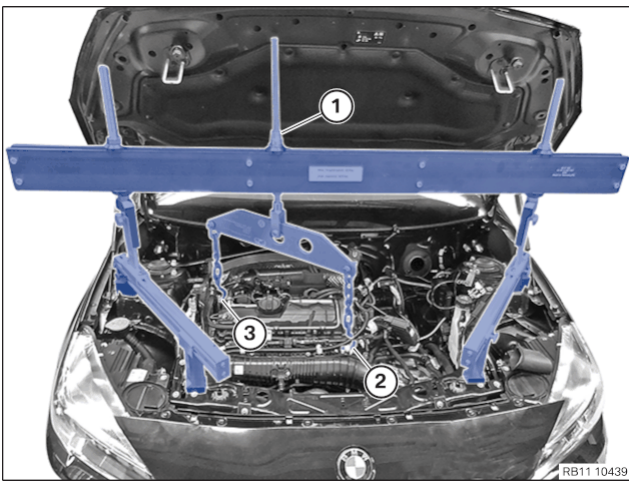

- Release nut (1) of the engine bridge.
- Release hooks (2) and (3) from the engine mounting bracket.
- Guide the engine bridge out of the vehicle with the help of another person and remove.

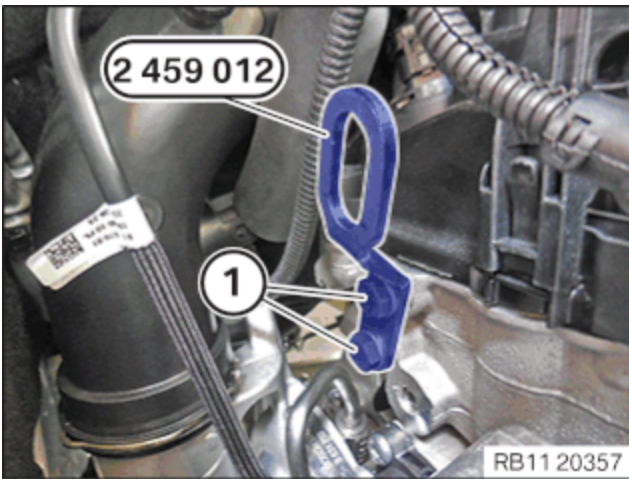

- **If no engine mounting bracket is installed:**
- Unscrew the bolts (1) of the special tool **2 459 012**.
- Feed out the special tool **2 459 012** at the cylinder head and remove.

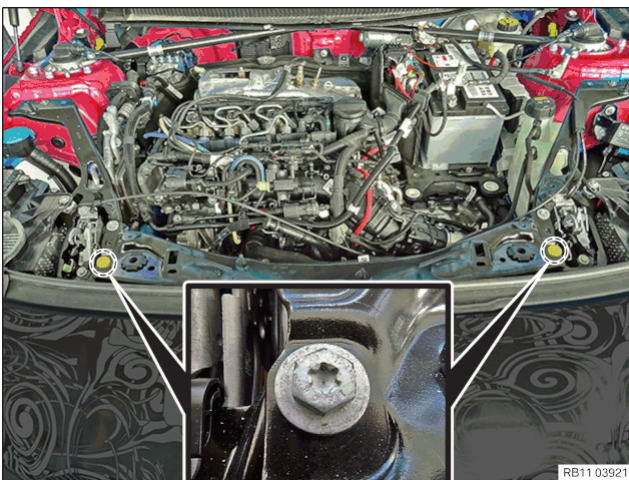

- Tighten front cross connection bolts.

#### **Cross connection on bonnet catch support**

Hexagon screw	Tightening torque	28 Nm
---------------	-------------------	-------

### **59 – Installing rear bulkhead upper part**

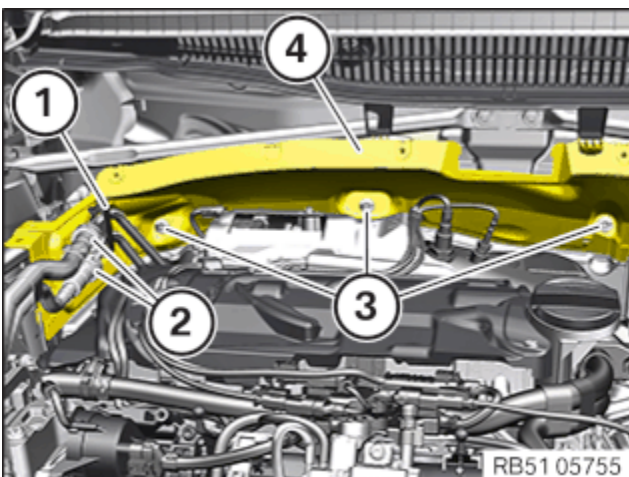

- Feed in and install the rear bulkhead upper part (4).
- Tighten the screws (3).

#### **Rear bulkhead upper part to lower section of bulkhead**

Oval-head screw	Tightening torque	5 Nm
-----------------	-------------------	------

- Feed the fuel line (2) into the holder (1) and install.
  - Connect the holder (1) and lock.
- The holder (1) must engage audibly.

## 60 – Installing the upper bulkhead cover

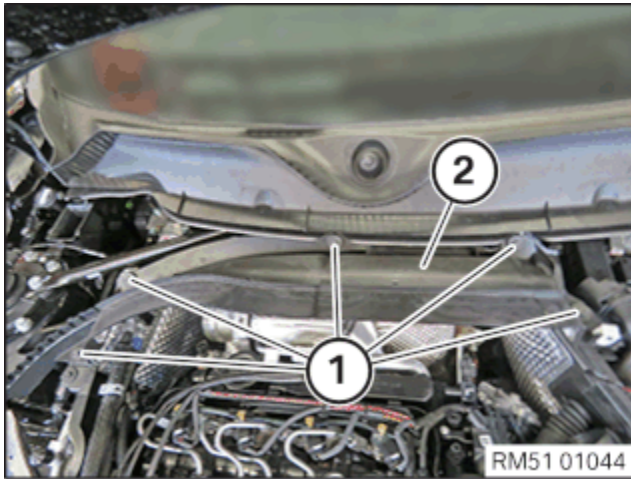

- Feed in and install cover (2) of the bulkhead at the top.
- Tighten the screws (1).

### Bulkhead cover, top

Screw	Tightening torque	3 Nm
-------	-------------------	------

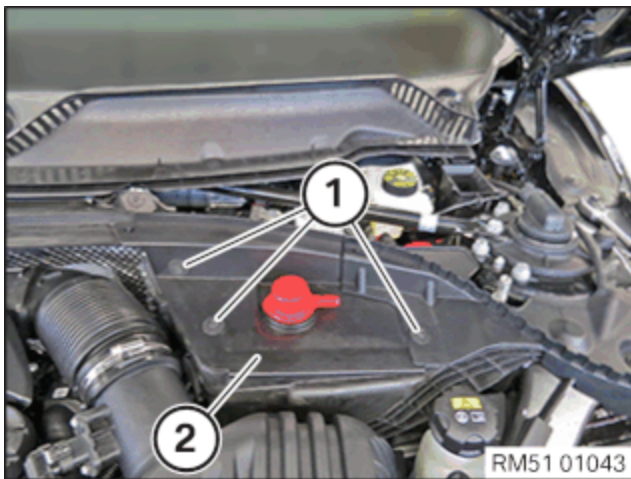

- Guide in and install cover (2).
- Tighten the screws (1).

### Positive battery connection point cover to engine compartment partition wall

	Tightening torque	3 Nm
--	-------------------	------

## 61 – If installed: Install strut brace

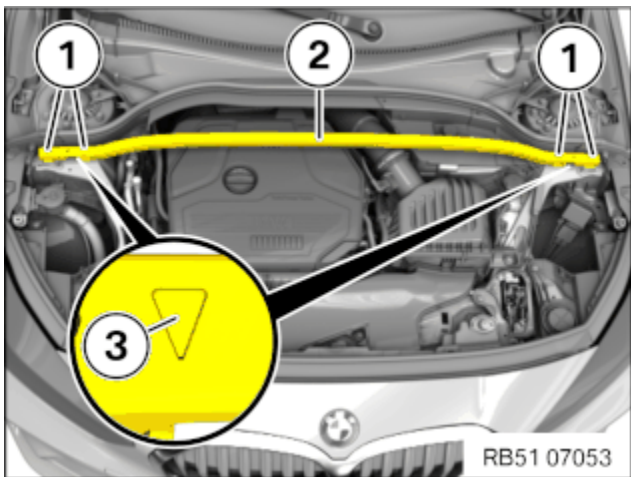

- Install the strut brace (2).  
When installing, make sure the arrow (3) points in the direction of travel.
- Renew screws (1).  
**Parts:** Bolts
- Tighten the screws (1).

### Suspension cross brace to body

M8x45 Hexagon screw	Renew screws.	Tightening torque	28 Nm
		Angle of rotation	180°

## 62 – Installing front cowl panel cover

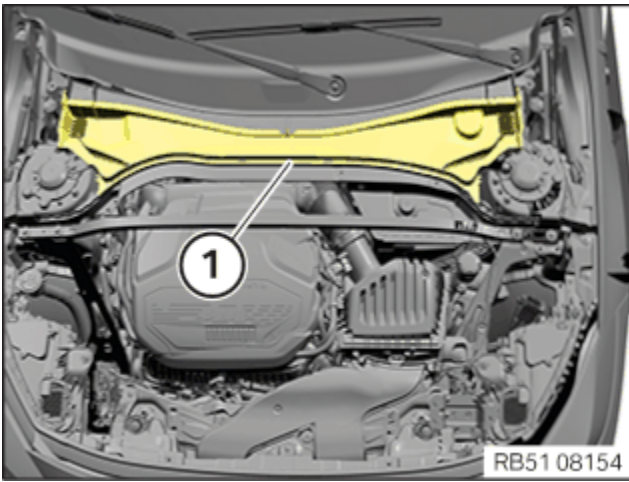

Schematic diagram is for example purposes. Some parts may differ in certain details.

- Guide the front cowl panel cover (1) towards the rear into the rear cowl panel cover and install.
- Ensure correct fit of the front cowl panel cover (1) relative to the rear cowl panel cover.

### ► Attach cable (equipment specification with Electronic Damper Control)

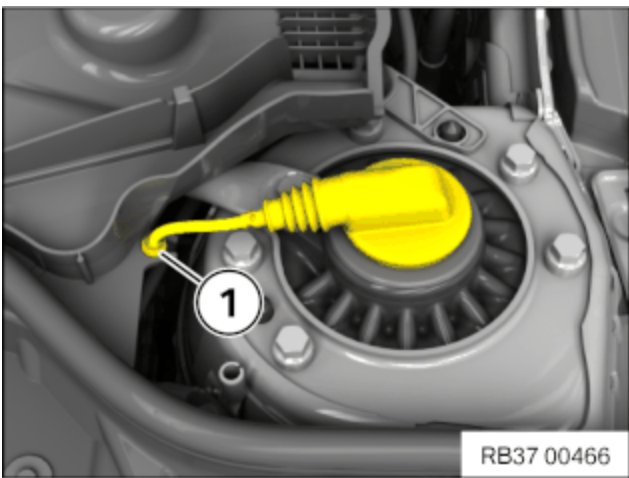

- Clip cable (1) into the front cowl panel cover.

## 63 – Installing the mounting of the bonnet seal

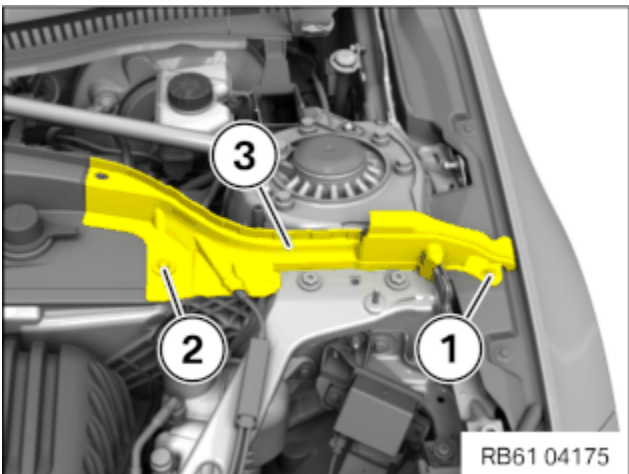

- Position the mounting (3) of the bonnet seal.
- Tighten down screw (2).

### Seal support to tension strut

Hexagon screw for thermoplastic	Tightening torque	2,6 Nm
---------------------------------	-------------------	--------

- Fasten expanding rivet (1).

## 64 – Install the seal for the bonnet



Schematic diagram is for example purposes. Some parts may differ in certain details.

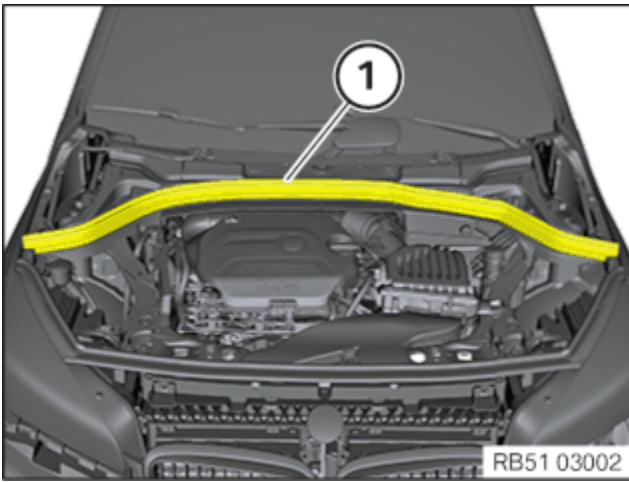

- Install the bonnet seal (1) and ensure correct fit.

## 65 – Connecting all battery earth leads



- See additional information.

## 66 – Install acoustic cover



### **Damage to the acoustic cover/design cover.**

**Jerky movements during disassembly and excessive application of force during installation may result in breakage of the acoustic cover/design cover.**

- Disassemble or mount the acoustic cover/design cover carefully.
- Disassemble or mount snap-lock couplings of the ball pivots one after the other.
- Disassemble or mount acoustic cover/design cover only at temperatures  $>20\text{ }^{\circ}\text{C}$ .
- Use only distilled water as an auxiliary material during installation, no lubricants.

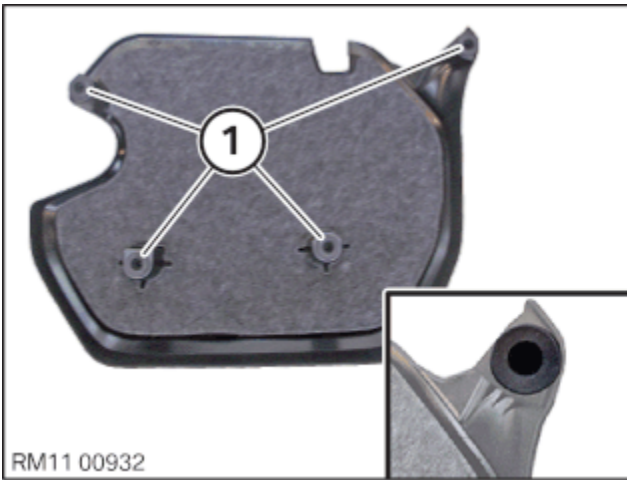

- Check for correct installation of all rubber mounts in the acoustic cover (1).



- Clip in the acoustic cover into the holders in the indicated areas.
- Make sure that the acoustic cover engages audibly.

## 67 – Take bonnet out of the service position



**Shutting bonnet or tailgate.**

**Danger of injury!**

- Support bonnet/tailgate in fully open position with the aid of a suitable device.

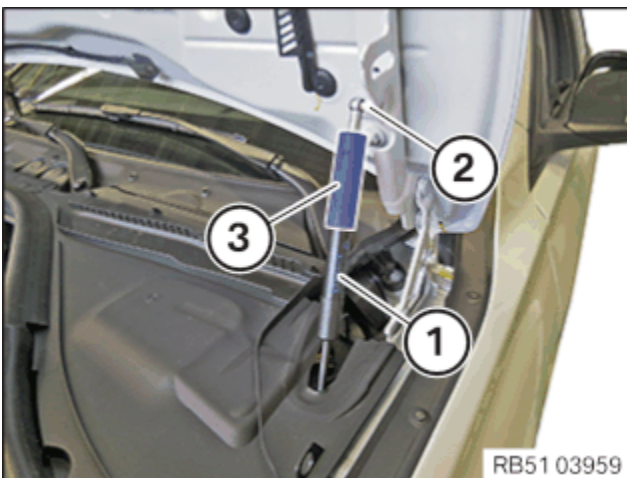

- Support the bonnet by hand.
- Remove the special tool (3) from the ball pin (2).
- Pull off the special tool (3) from the gas pressure spring (1).
- Continue to support the bonnet and repeat the operation on the other side of vehicle.

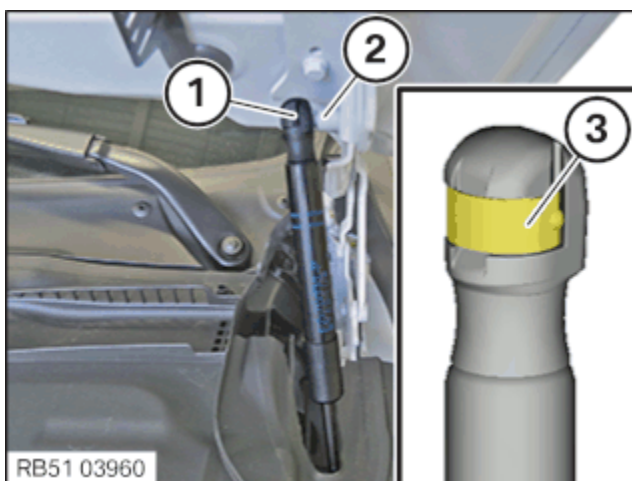

- Check the clamp (3) is fitted correctly.
- Connect ball socket (1) to ball pin (2).
- Continue to support the bonnet and repeat the operation on the other side of vehicle.

## Additional Information

### Overview of Tightening Torques

<b>Special tool to cylinder head</b>		Used in step <a href="#">9</a>	
M8		Tightening torque	21,5 Nm
<b>Transmission to engine</b>		Used in step <a href="#">33</a>	
M8x40		Tightening torque	19 Nm
M12x75		Tightening torque	66 Nm
<b>Transmission mounting</b>		Used in step <a href="#">33</a>	
M10	Renew screws.	Jointing torque	40 Nm
		Angle of rotation	90 °
<b>Clutch slave cylinder to transmission housing</b>		Used in step <a href="#">33</a>	
M8		Tightening torque	19 Nm
<b>Battery holder to engine support</b>		Used in step <a href="#">33</a>	
Hexagon screw M8x30		Tightening torque	19 Nm
<b>Battery terminal rail to battery tray</b>		Used in step <a href="#">33</a> <a href="#">55</a>	
M8			19 Nm
<b>Battery terminal rail to battery tray</b>		Used in step <a href="#">33</a>	
M8 screw		Tightening torque	15 Nm
<b>Electronics box to battery tray</b>		Used in step <a href="#">33</a>	
M8X16		Tightening torque	15 Nm

<b>Wiring harness to cylinder head cover</b>			Used in step <a href="#">33</a>
TS5x20		Tightening torque	3,5 Nm
<b>Cover to electronics box</b>			Used in step <a href="#">33</a>
RF5x26.5		Tightening torque	2,5 Nm
<b>Positive battery terminal to battery</b>			Used in step <a href="#">33</a>
NutM6		Tightening torque	5 Nm
<b>Tension strut to spring strut dome/battery tray</b>			Used in step <a href="#">33</a>
M8		Tightening torque	19 Nm
<b>Starter motor to transmission</b>			Used in step <a href="#">34</a>
M8x45		Tightening torque	19 Nm
<b>Battery positive lead to starter</b>			Used in step <a href="#">34</a>
M8		Tightening torque	13,5 Nm
<b>Output shaft bearing to engine block</b>			Used in step <a href="#">35</a>
M10		Tightening torque	38 Nm
<b>Transmission to oil sump</b>			Used in step <a href="#">37</a>
M8			19 Nm
<b>Rear end of front axle support to body</b>			Used in step <a href="#">38</a>
M14 screw	Renew screw.	Tightening torque	175 Nm
<b>Front axle support, front to body</b>			Used in step <a href="#">38</a>
M12 screw	Renew screw.	Tightening torque	108 Nm
<b>Underbody panelling, side</b>			Used in step <a href="#">38</a>
Hexagon screw		Tightening torque	2,6 Nm
<b>Holder, wishbone rubber mount, to body</b>			Used in step <a href="#">39</a>
M10 screw	Renew screw.	Jointing torque	56 Nm
		Angle of rotation	90 °
<b>Holder with rubber mount to front axle support</b>			Used in step <a href="#">39</a>
M12 screw			100 Nm
<b>Deformation element, bottom, to adapter plate, front axle carrier</b>			Used in step <a href="#">39</a>
Screw		Tightening torque	11,8 Nm

<b>Holder for external radiator on deformation element</b>			Used in step <a href="#">39</a>
M6 screw		Tightening torque	8 Nm
<b>Track rod end to swivel bearing</b>			Used in step <a href="#">40</a>
M14	Renew nut.	Tightening torque	175 Nm
<b>Wishbone to swivel bearing</b>			Used in step <a href="#">41</a>
M10	Exclusively use the screw to tighten! Renew screw and nut.	Tightening torque	56 Nm
<b>Anti-roll bar link to anti-roll bar/spring strut</b>			Used in step <a href="#">44</a>
M10	Renew nut.	Tightening torque	56 Nm
<b>Wheel arch cover to body</b>			Used in step <a href="#">46</a>
Hexagon screw		Tightening torque	2,6 Nm
<b>Wheel arch cover to body</b>			Used in step <a href="#">46</a>
Plastic nut		Tightening torque	2,6 Nm
<b>Wheel arch cover to brake air duct</b>			Used in step <a href="#">46</a>
Hexagon screw		Tightening torque	2,6 Nm
<b>Front bottom cover at the side to front bumper panel</b>			Used in step <a href="#">47</a>
Hexagon screw for thermoplastic		Tightening torque	3 Nm
<b>Brake disc to front wheel hub</b>			Used in step <a href="#">48</a>
M8		Tightening torque	16 Nm
<b>Brake disc to rear wheel hub</b>			Used in step <a href="#">48</a>
M8		Tightening torque	16 Nm
<b>Wheel bolts</b>			Used in step <a href="#">48</a>
M 14/AF 17	Screw in wheel bolts and evenly tighten crosswise by hand in order to centre the wheel rim.	Tightening torque	140 Nm
	Tighten wheel bolts to the prescribed tightening torque with a calibrated torque wrench in a crosswise sequence.	Check	140 Nm
	Check all the wheel bolts in the same order or retighten to the prescribed tightening torque again.		

<b>Lower steering shaft to steering gear</b>			Used in step <a href="#">50</a> <a href="#">54</a>
M10	Clean screw thread and remove remains of screw locking agent. Renew screw.	Tightening torque	28 Nm
<b>Steering column cover to bulkhead</b>			Used in step <a href="#">50</a> <a href="#">54</a>
Plastic nut		Tightening torque	3 Nm
<b>Underbody protection to body</b>			Used in step <a href="#">51</a> <a href="#">52</a>
Screw		Tightening torque	2.5 Nm
<b>Front underbody protection on body/front axle support</b>			Used in step <a href="#">52</a>
M6x20 screw		Tightening torque	8 Nm
<b>Cross-member on front axle support</b>			Used in step <a href="#">52</a>
M10x35	Renew screw.	Tightening torque	56 Nm
		Tightening torque	45 °
<b>Battery terminal with IBS positive battery terminal / negative battery terminal</b>			Used in step <a href="#">55</a>
NutM6			5 Nm
<b>Trailing link</b>			Used in step <a href="#">55</a>
M8		Tightening torque	19 Nm
<b>Battery cover</b>			Used in step <a href="#">55</a>
M8			2,8 Nm
<b>Intake silencer housing to lock bridge</b>			Used in step <a href="#">56</a>
M6X30		Tightening torque	8 Nm
<b>Clean air pipe to intake silencer housing</b>			Used in step <a href="#">56</a>
Clamp		Tightening torque	3 Nm
<b>Intake neck to cross connection</b>			Used in step <a href="#">57</a>
M6		Tightening torque	8 Nm
<b>Cross connection on bonnet catch support</b>			Used in step <a href="#">58</a>
Hexagon screw		Tightening torque	28 Nm
<b>Rear bulkhead upper part to lower section of bulkhead</b>			Used in step <a href="#">59</a>
Oval-head screw		Tightening torque	5 Nm

**Bulkhead cover, top** Used in step [60](#)

Screw Tightening torque 3 Nm

**Positive battery connection point cover to engine compartment partition wall** Used in step [60](#)

Tightening torque 3 Nm

**Suspension cross brace to body** Used in step [61](#)

M8x45 Hexagon screw Renew screws. Tightening torque 28 Nm

Angle of rotation 180 °

**Seal support to tension strut** Used in step [63](#)

Hexagon screw for thermoplastic Tightening torque 2,6 Nm

## Overview of Special Tools

### 2 459 012 Holder



**Common** Used in step [9](#) [58](#)

Usage For removing and installing the cylinder head. Contour-graphic silhouette foil is included in the delivery specification.

Included in the tool or work

Storage location A58

Replaced by

In connection with

SI-Number 01 07 17 (487)

### 0 496 852 (00 6 100) Device

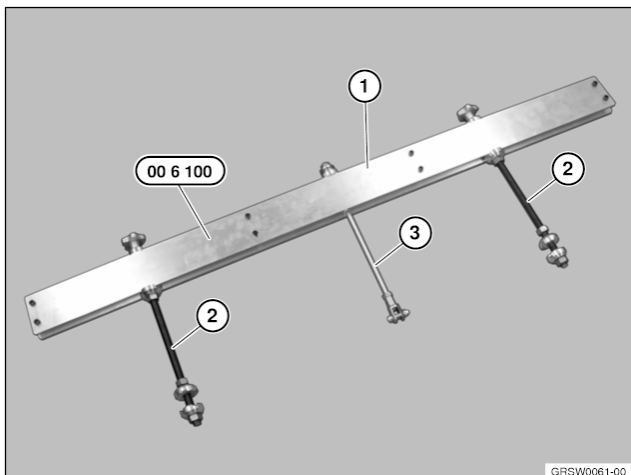

**Common** Used in step [9](#)

Usage Engine bridge (device) 006000 (Classic SWZ)

Included in the tool or work

Storage location Individual

Replaced by

In connection with

SI-Number 01 17 10 (659)

### Consisting of

Pos	BMW Order number	Replaced by	Designation	In Connection with
2	<a href="#">2 361 507 (00 6 102)</a>		<b>Spindle</b> Set (2 pieces) in connection with 00 6 100.	
3	<a href="#">2 361 506 (00 6 103)</a>		<b>Spindle</b> Spindle (central spindle) for Traverse 00 6 100.	

### 0 490 133 (00 2 030) Device

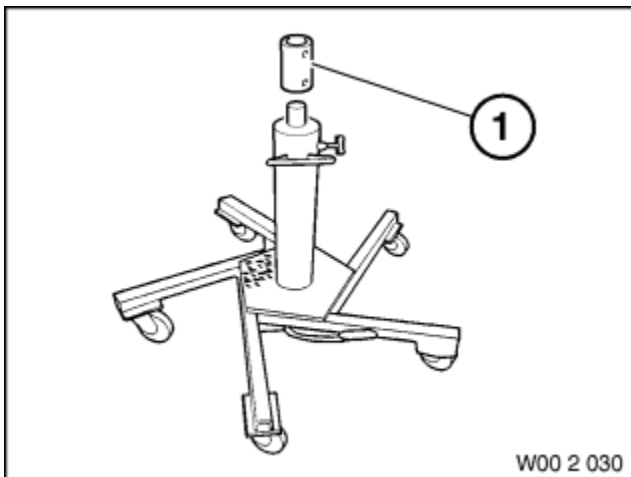

### Common

Used in step [26](#) [27](#) [32](#) [33](#) [38](#)

Usage (universal hydraulic lifter base unit) Chassis and hydraulic lifter - For removing and installing rear axle supports and gearboxes. Also for soft top mounts. Is replaced by 81 22 2 219 012

Included in the tool or work

Storage location

Replaced by

In connection with

SI-Number 01 05 90 (207)

### Consisting of

Pos	BMW Order number	Replaced by	Designation	In Connection with
1	<a href="#">0 490 134 (00 2 031)</a>		<b>Adapter</b> (adapter for gearbox holder) Model series: E30, E31, E32, E34, E36	

## 2 344 011 Tool



### Common

Used in step [48](#)

#### Usage

Tool (wheel hub grinder) for cleaning the connection of the wheel rim (wheel contact face) to the wheel hub.

#### Included in the tool or work

#### Storage location

#### Replaced by

#### In connection with

SI-Number 08 08 12 (872)

## Replacement tools:

### 0 495 221 (36 1 323) Wheel stud

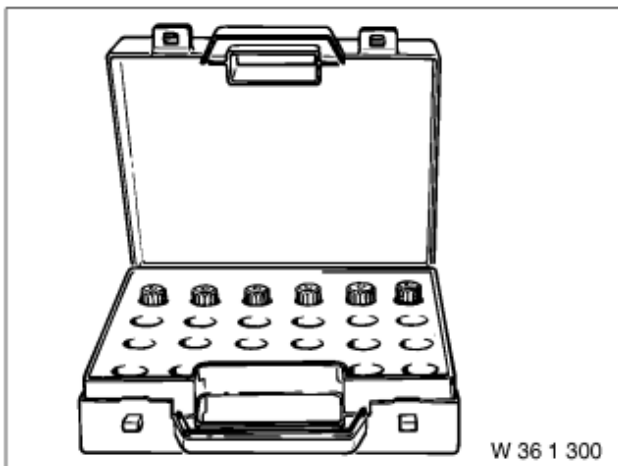

### Common

Used in step [16](#)

#### Usage

(Code 30) Code 39 available separately, (see EPC) under 36 13 1 181 259

#### Included in the tool or work

0 492 518

#### Storage location

#### Replaced by

#### In connection with

#### SI-Number

### 0 495 224 (36 1 326) Wheel stud

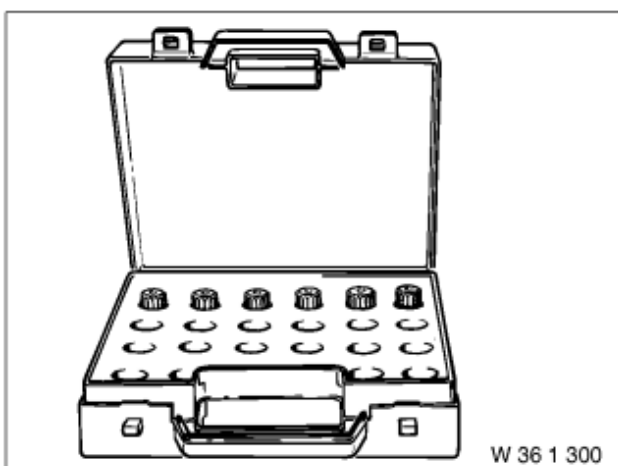

### Common

Used in step [16](#)

#### Usage

(Code 33) With centring bore available separately, (see EPC) under 36 13 6 765 546

#### Included in the tool or work

0 492 518

#### Storage location

#### Replaced by

#### In connection

with  
SI-Number

### 0 495 225 (36 1 327) Wheel stud

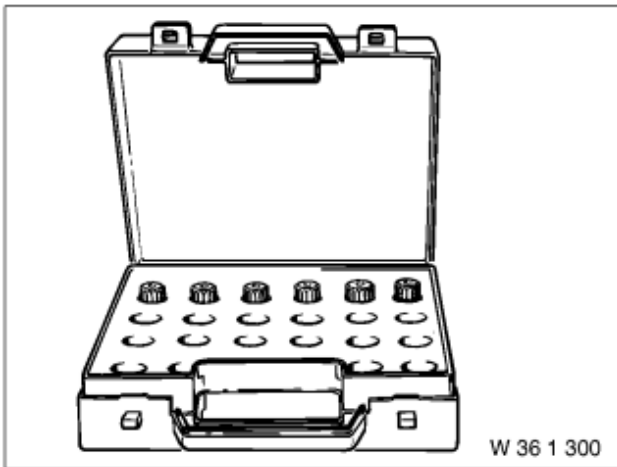

**Common** Used in step [16](#)

---

Usage (Code 34) With centring bore available separately (see EPC) under 36 13 6 765 547

Included in the tool or work 0 492 518

Storage location

Replaced by

In connection with

SI-Number

### 0 495 226 (36 1 328) Wheel stud

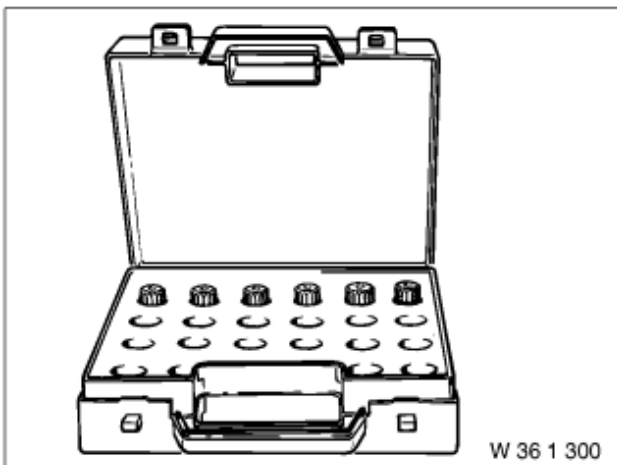

**Common** Used in step [16](#)

---

Usage (Code 35) With centring bore available separately, (see EPC) under 36 13 6 762 340

Included in the tool or work 0 492 518

Storage location

Replaced by

In connection with

SI-Number

### 0 495 227 (36 1 329) Wheel stud

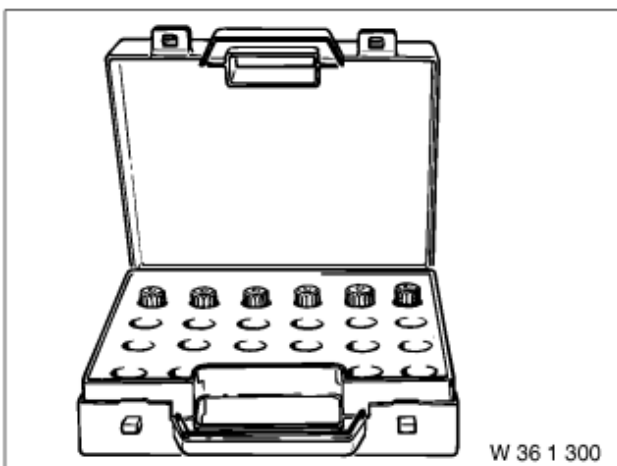

**Common** Used in step [16](#)

---

Usage (Code 36) With centring bore available separately (see EPC) under 36 13 6 762 341

Included in the tool or work 0 492 518

Storage location

Replaced by

In connection  
with

SI-Number

### 0 495 228 (36 1 331) Wheel stud

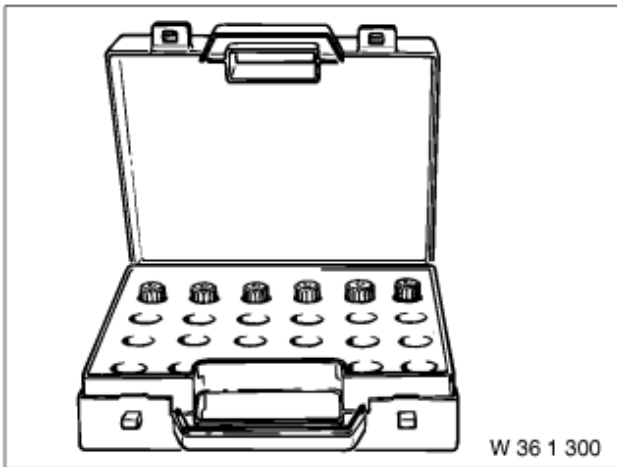

#### Common

Used in step [16](#)

Usage (Code 37) With centring bore available separately (see EPC) under 36 13 6 762 342

Included in the tool or work 0 492 518

Storage location

Replaced by

In connection with

SI-Number

### 0 495 229 (36 1 332) Wheel stud

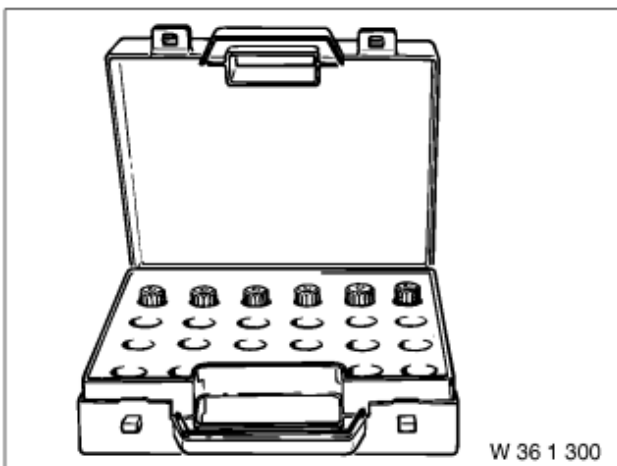

#### Common

Used in step [16](#)

Usage (Code 38) With centring bore available separately (see EPC) under 36 13 6 762 343

Included in the tool or work 0 492 518

Storage location

Replaced by

In connection with

SI-Number

### 0 495 230 (36 1 333) Wheel stud

#### Common

Used in step [16](#)

Usage (Code 40) With centring bore available separately (see EPC) under 36 13 6 762 344

Included in the tool or work 0 492 518

Storage location

Replaced by

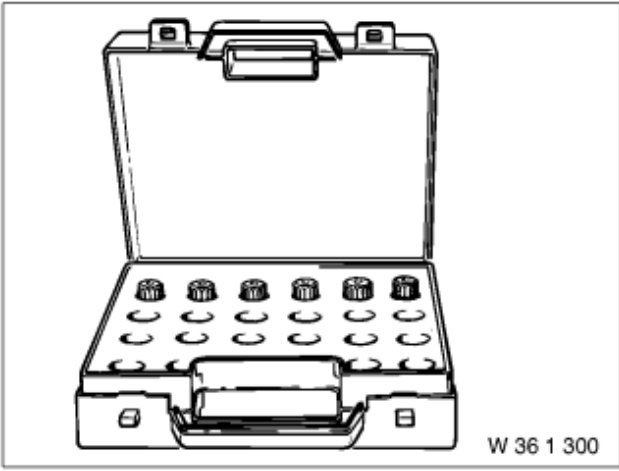

In connection  
with  
SI-Number

**Links**