

## 11 00 050 Removing and installing engine



**Working on 12 V vehicle electrical system.**

**Risk of short circuits! Risk of fire!**

- Make sure that **no charger** is connected to the jump start support point in the engine compartment.
- Detach battery earth lead from battery.
- With auxiliary batteries: Detach all battery earth leads from additional batteries.



**Motor vehicle may slip off the vehicle hoist where components are supported.**

**Danger! Life-threatening injuries!**

- Secure the vehicle hoist against lowering and lifting.



**Motor vehicle may slip off the vehicle hoist if the weight is distributed unevenly.**

**Danger! Life-threatening injuries!**

- Ensure there is a specific weight compensation on the motor vehicle.



**Vehicle may slip off the vehicle hoist if the vehicle hoist is handled incorrectly.**

**Danger! Life-threatening injuries!**

- Observe safety information on raising the vehicle using a vehicle hoist.
- For additional information see: 00 ... Raise the vehicle using a vehicle lift.



**Damage to battery terminal, the safety battery terminal or the intelligent battery sensor (IBS).**

**Damaged battery terminals can lead to malfunctions or vehicle electrical system faults.**

- Pull off battery terminal from battery pole by carefully moving to and fro. Do not pry off using a tool.

### PRELIMINARY WORK

---

#### 1 – Bring front compartment lid in the service position

##### Prerequisite

Engine compartment lid is open.



**Shutting bonnet or tailgate.**

**Danger of injury!**

- Support bonnet/tailgate in fully open position with the aid of a suitable device.

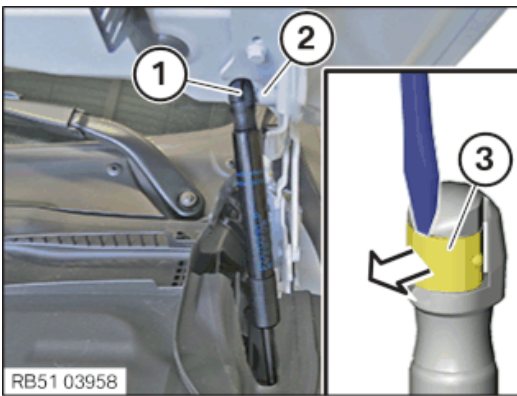

RB51 03958

- Lift clamp (3) slightly using a screwdriver, in the direction of the arrow.
- Release ball socket (1) from ball pin (2).
- Repeat the operation on the other side of vehicle.

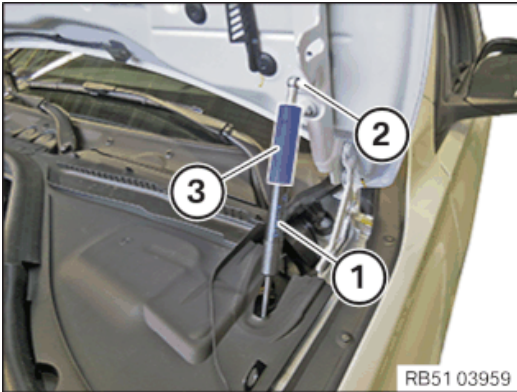

RB51 03959



Conduct the following operation with the assistance of a second person.

- Remove the bonnet support and open the bonnet further.
- Push special tool **0 493 200 (51 2 160)**(3) over gas pressure spring (1).
- Position the special tool **0 493 200 (51 2 160)**(3) on the ball pin (2) and apply force to engage it.
- Repeat the operation on the other side of vehicle.

## 2 – Disconnecting all battery earth leads



RB61 04141

- See additional information.

## 3 – Removing the front underbody protection

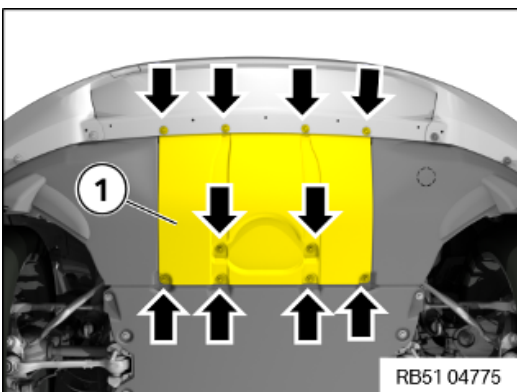

RB51 04775

- Remove screws (arrows).
- Feed out the front underbody protection (1).

## 4 – Remove the wheel arch cover on the front left and bottom right



Description is for left component only. Procedure on the right side is identical.

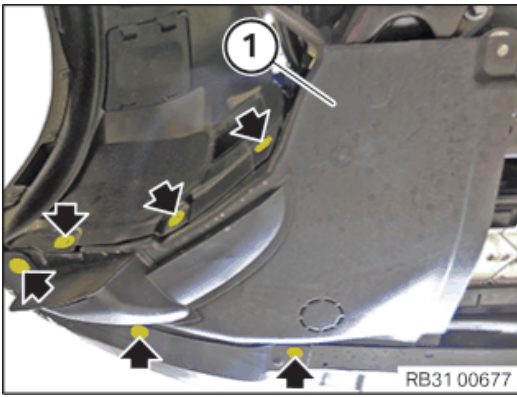

- Release all bolts (arrows).
- Guide the wheel arch cover (1) out.

### 5 – Removing the centre underbody protection

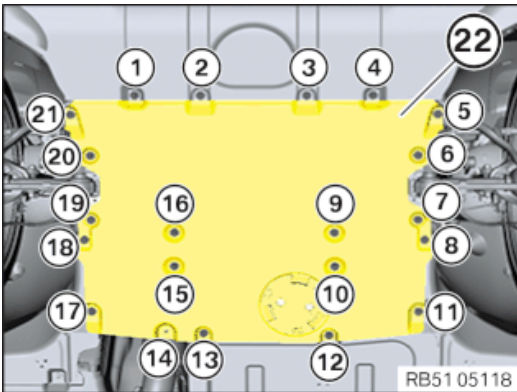

- Loosen screws (1) to (21).
- Guide out the centre underbody protection (22) at an angle toward the rear.

### 6 – Remove the cover of the steering assembly



To provide a better overview: Schematic diagram with partially hidden components.

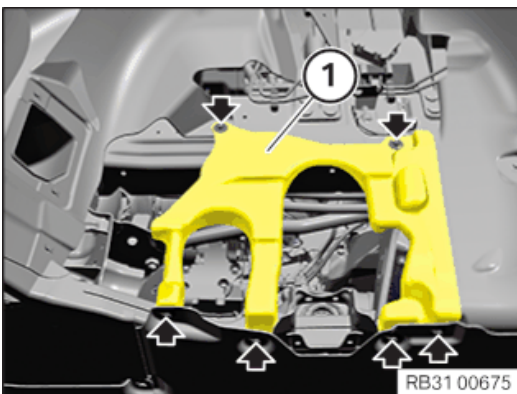

- Release all bolts (arrows).
- Remove cover (1).

### 7 – Removing rear underbody protection

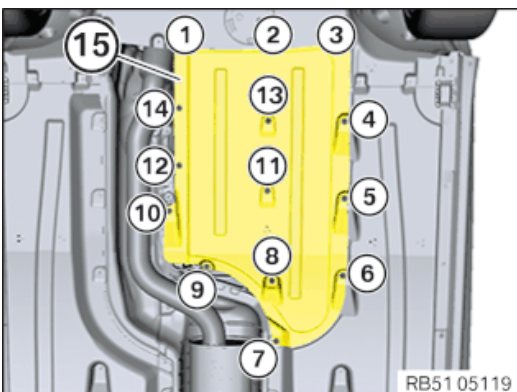

- Loosen screws (1) to (14).
- Guide out the rear underbody protection (15) at an angle toward the rear.

### 8 – Removing cover on the exhaust system

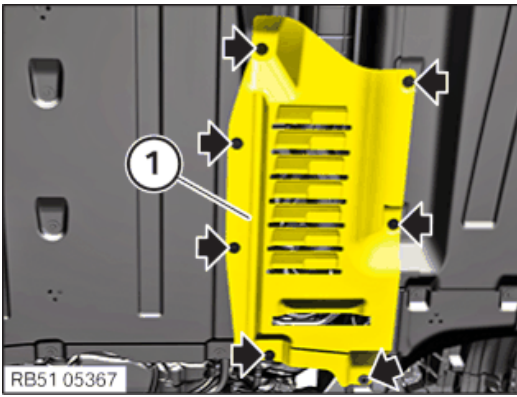

- Remove screws (arrows).
- Guide out and remove the cover (1).

### 9 – Remove the seal for the rear bonnet

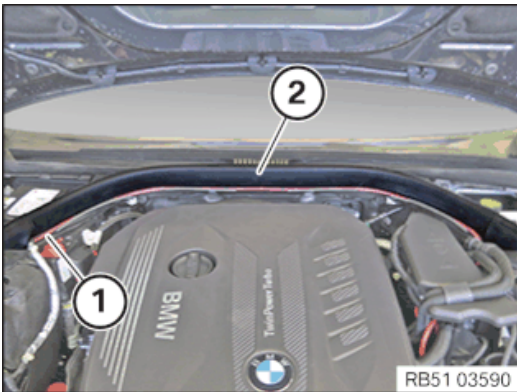

- Feed the cable (1) out of the brackets toward the front.
- Remove the rear bonnet seal (2) from the guide toward the inside.

### 10 – Remove the cover of the engine compartment at the rear left

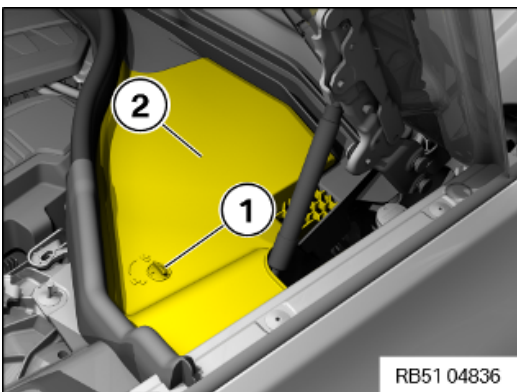

- Loosen the lock (1).
- Remove the cover (2).

### 11 – Remove the cover of the rear right engine compartment

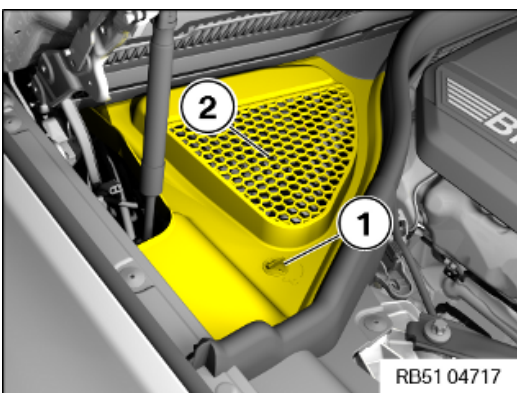

- Loosen the lock (1).
- Remove the cover (2).

### ► Covering the vehicle battery



### Unprotected battery terminals.

**Risk of short circuits! Risk of fire!**

- Cover the vehicle battery.

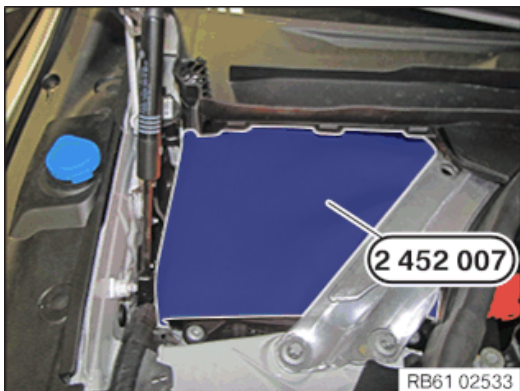

The following work step(s) is / are to be carried out if the specified component(s) is/are fitted.

- Cover the battery with the special tool **2 452 007** as shown.

## 12 – Remove left and right wiper arm



Description is for left component only. Procedure on the right side is identical.

### ► Remove the wiper arm



#### Damage to wiper console.

**While removing the wiper arms without using special tool, the wiper console can break.**

- Removing the wiper arms must be carried out only using the prescribed special tool.
- Do **not** lever off the wiper arm because otherwise the wiper console may break at the predetermined breaking point for active pedestrian protection.

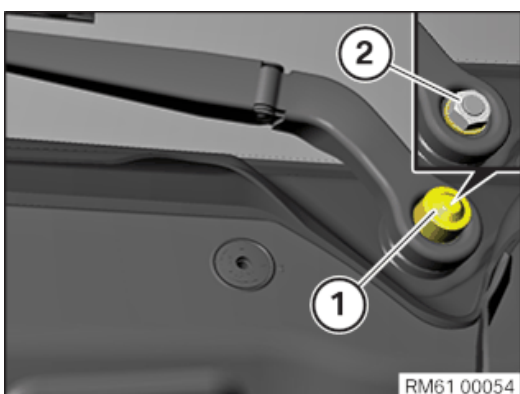

- Remove the protective cap (1).
- Loosen nut (2).

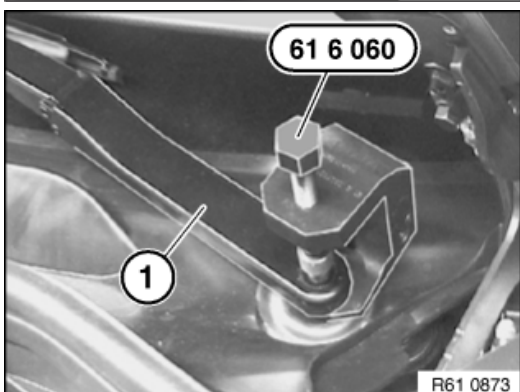

- Pull off the wiper arm (1) using special tool .

### 13 – Remove cowl panel cover

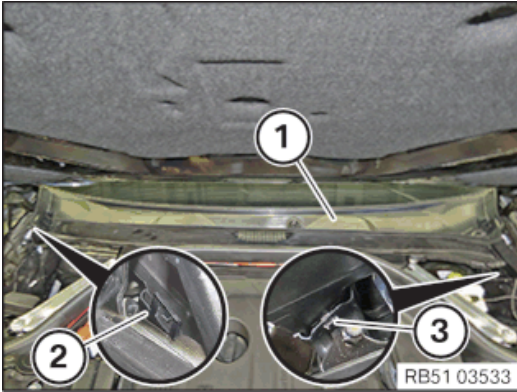

- Release the cowl panel cover (1) from the latch mechanisms (2) and (3).
- Pull off the cowl panel cover (1) towards the top, starting from the side.

### 14 – Remove the bulkhead upper part

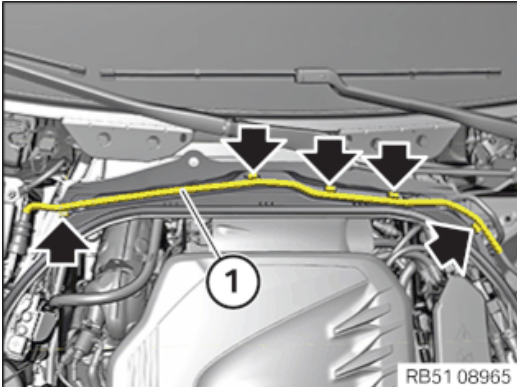

- **Version with mild hybrid technology:**  
Unclip the wire (1) at the holders (arrows).

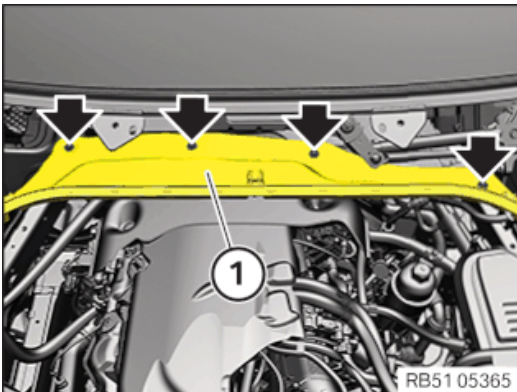

- Remove screws (arrows).
- Guide out the bulkhead upper part (1) and remove.

### 15 – Removing the acoustic cover



#### **Damage to the acoustic cover/design cover.**

**Jerky movements during disassembly and excessive application of force during installation may result in breakage of the acoustic cover/design cover.**

- Disassemble or mount the acoustic cover/design cover carefully.
- Disassemble or mount snap-lock couplings of the ball pivots one after the other.
- Disassemble or mount acoustic cover/design cover only at temperatures  $>20\text{ }^{\circ}\text{C}$ .
- Use only distilled water as an auxiliary material during installation, no lubricants.



- Unclip the acoustic cover (1) from the holders in the indicated area towards the top.

## 16 – Remove the acoustic cover for the injectors

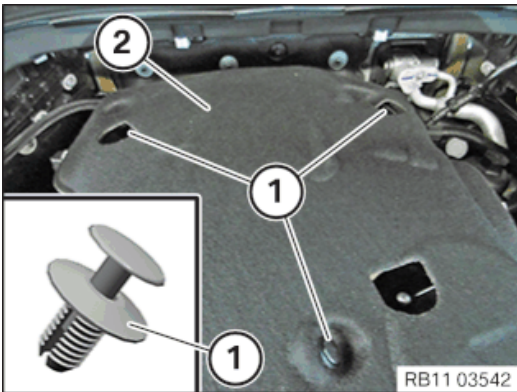

- **If installed:** Release the expanding rivet (1).
- Guide the acoustic cover (2) out and remove.

## 17 – Remove resonator



**Hot surfaces.**

**Risk of burning!**

- Perform all work only on components that have cooled down.

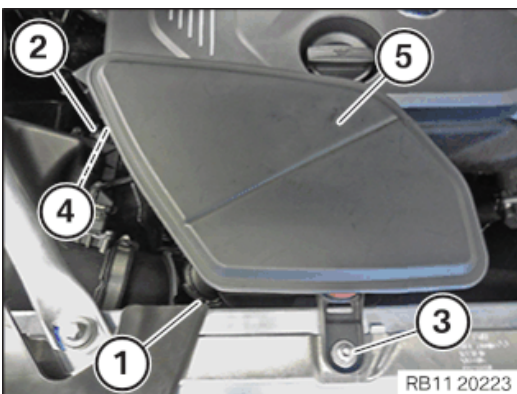

- Unfasten clamp (1).
- Loosen screw (2).
- Loosen screw (3).
- Loosen clamp (4).
- Guide out and remove the resonator (5).

## 18 – Removing the top right and left cover in the engine compartment



Description is for left component only. Procedure on the right side is identical.

- ▶ **Remove the cover in the engine compartment on top**

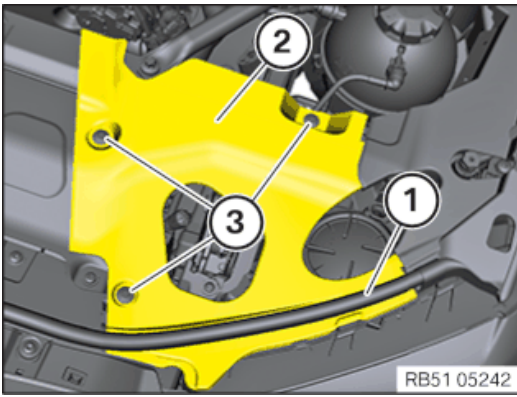

- Detach the bonnet seal (1) in area of the cover (2).
- Loosen the expanding rivet (3).
- Guide out and remove the cover (2).

## 19 – Remove front cross connection

### ► Remove front cross connection

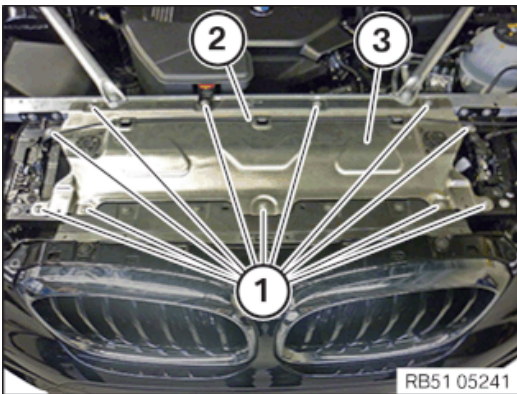

- Loosen screws (1).
- Detach the Bowden cable (2).
- Feed out the cross connection (3) and remove in an upward direction.

## 20 – Removing left and right front-end strut

### ► Remove left front-end strut

**i**

Driving without the strut brace/front-end strut or tension strut is not permitted.

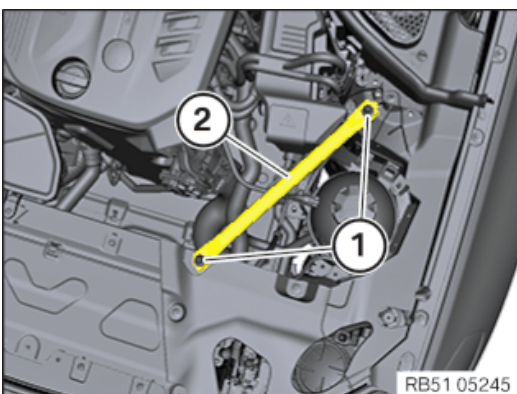

- Loosen screws (1).
- Remove the front-end strut (2).

### ► Remove right front-end strut

**i**

Driving without the strut brace/front-end strut or tension strut is not permitted.

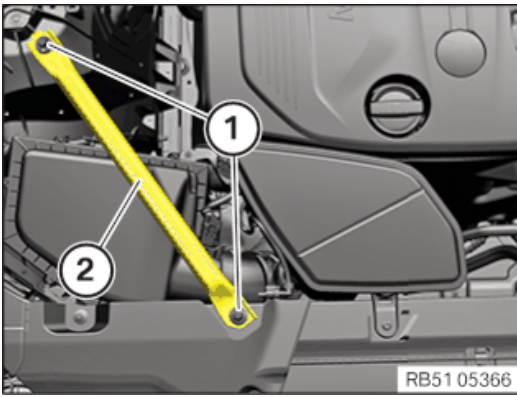

- Loosen screws (1).
- Remove the front-end strut (2).

## 21 – Remove the fixture of the bonnet seal on the left and right

### ► Remove the fixture for the left bonnet seal

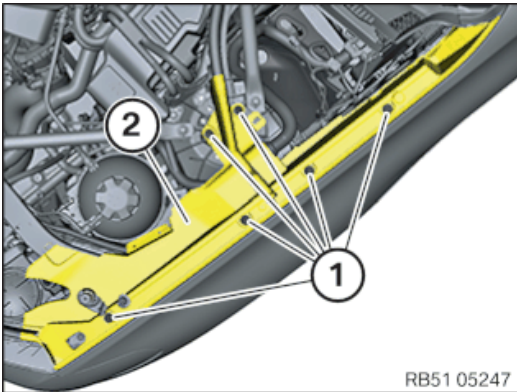

- Loosen the expanding rivet (1).
- Remove the mounting (2) for the left bonnet seal.

### ► Remove the fixture of the right bonnet seal

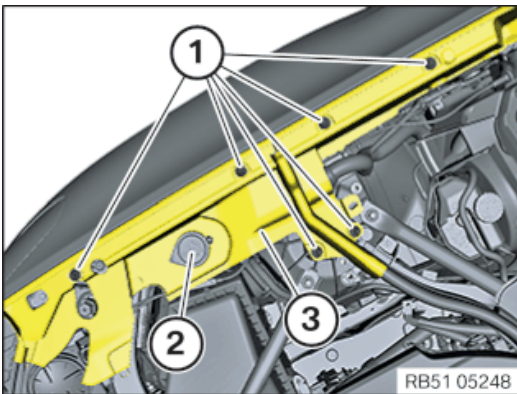

- Loosen the expanding rivet (1).
- Open and remove the lid (2) of the washer fluid reservoir.
- Remove the mounting (3) of the bonnet seal on the right.

## 22 – Remove the rear top cross connection

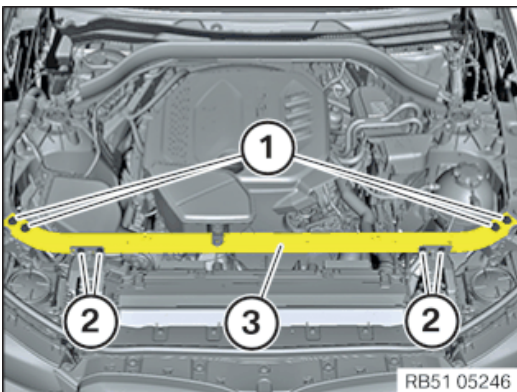

- Loosen screws (1).
- Loosen screws (2).
- Thread out and remove the top rear cross connection (3).

## 23 – Remove fan cowl.

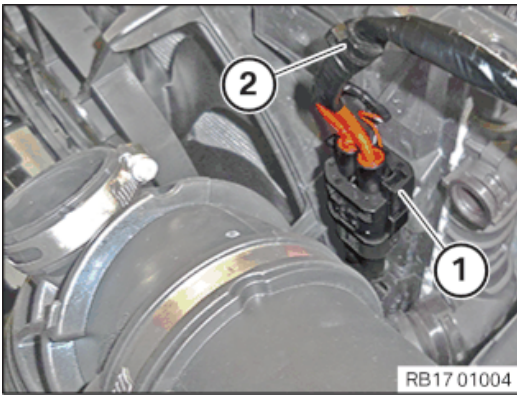

- Unlock connector (1) and pull off.
- Detach the clip (2) from the fan cowl.

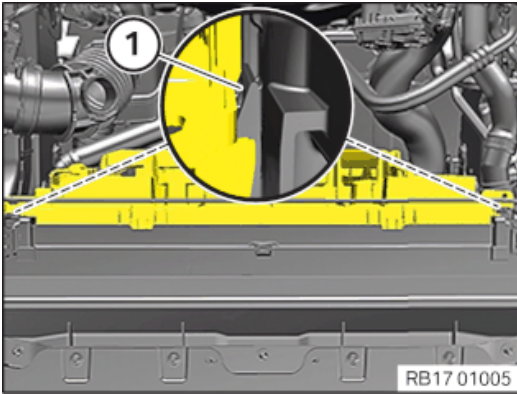

- Unlock the locks (1) on the left and right.

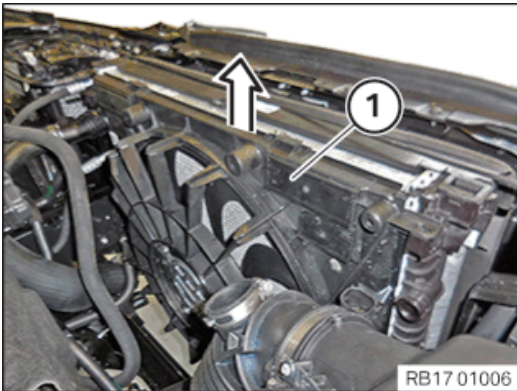

- Guide out fan cowl (1) in direction of arrow and remove.

## 24 – Remove acoustic cover of the front engine



**Hot surfaces.**

**Risk of burning!**

- Perform all work only on components that have cooled down.

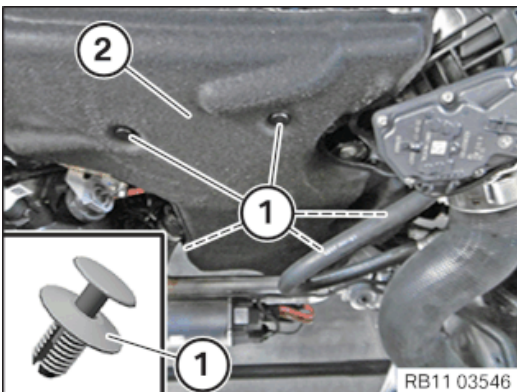

- Release and remove expanding rivet (1).
- Guide the acoustic cover (2) out and remove.

## 25 – Removing the drive belt for alternator



### Spring preload.

#### Danger of injury!

- The use of the specified special tool (tool) is mandatory.
- The described operation must be carried out properly.



### Component with preload.

#### Danger of injury!

- Reduce preload as far as possible before disassembly. Relieve component.



If the drive belt is reused: Mark direction of travel and reinstall drive belt in same direction of travel.



The drive belt must be replaced if contaminated with coolant- and oil residues.

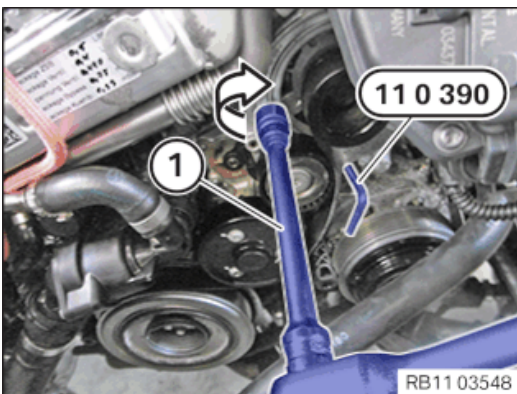

- If reusing the drive belt for alternator: Mark the direction of rotation.
- Relax the belt tensioner in the direction of the arrow using a standard tool (1).
- Fix the belt tensioner with the special tool **0 496 268 (11 0 390)**.

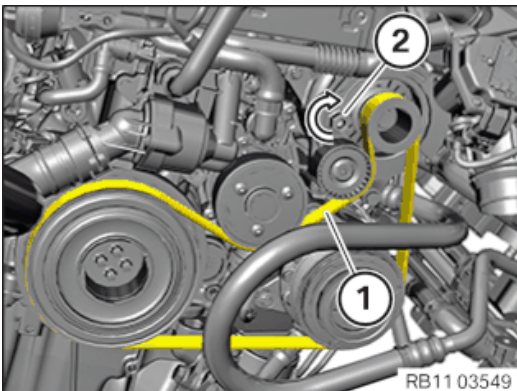

- Relieve belt tensioner at hexagon head (2) in direction of arrow up to limit position.
- Guide out and remove drive belt for alternator (1).

## 26 – Draining coolant



### Hot fluids.

#### Risk of scalding!

- Conduct all work in the vehicle wearing appropriate personal protective equipment only.



**Materials harmful to health.**

**Contact with fluids harmful to health!**

- Note and follow safety information on containers.
- Conduct all work in appropriate personal protective equipment only.



**Life-long fill of coolant!**

Do not reuse used coolant.

When replacing and removing components which rely on the corrosion protection effect of the coolant, it is essential to change the coolant. The cooling system must therefore be emptied and refilled.

In the case of other removal work involving the draining of part quantities of coolant, the coolant level must be topped up with new coolant.



Collect and dispose of emerging fluids. Observe country-specific waste disposal regulations.

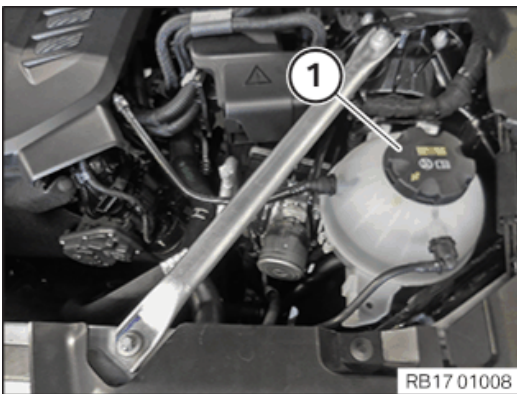

- Loosen sealing cap (1) from the coolant expansion tank.

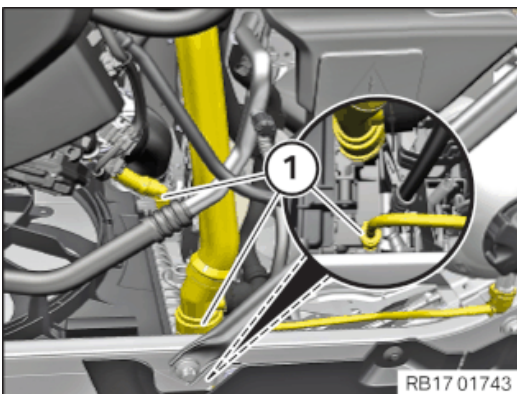

- Unlock and release the coolant lines (1).
- Catch and dispose of escaping coolant.

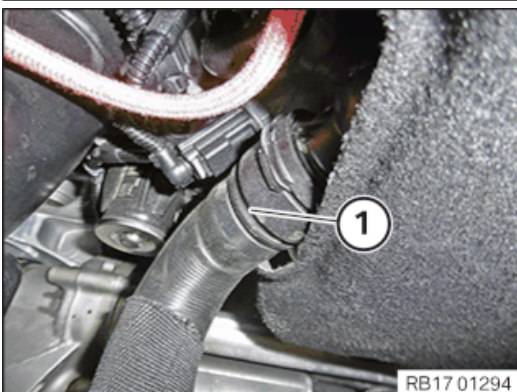

- Unlock and release the coolant line (1).
- Catch and dispose of escaping coolant.

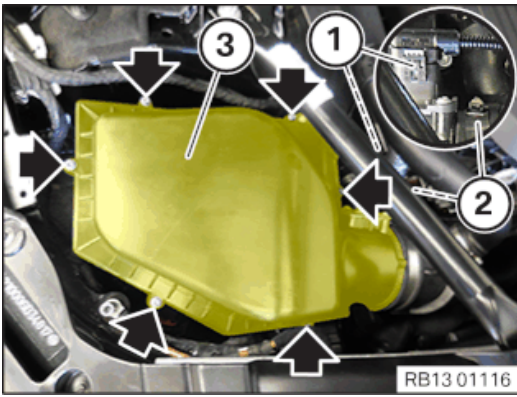

- Unlock and loosen connector (1).
- Unfasten clamp (2).
- Remove screws (arrows).
- Remove the upper section of the intake filter housing (3).

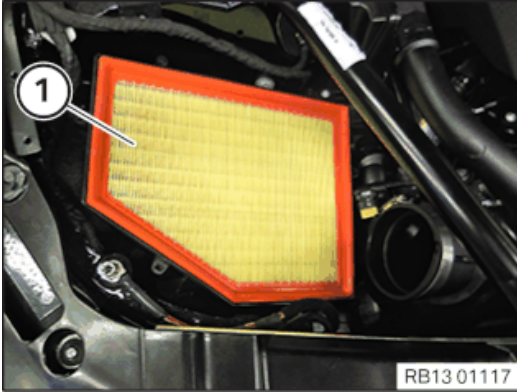

- Remove the air filter element (1).

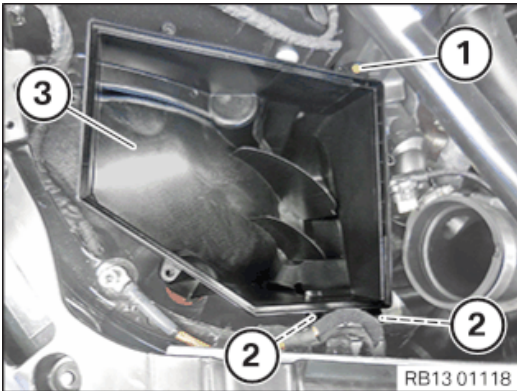

- Loosen screw (1).
- If installed: Unlock and loosen the clamps (2).
- Pull lower section of intake filter housing (3) upwards and out of the rubber mounts.

## 28 – Remove top clean air pipe

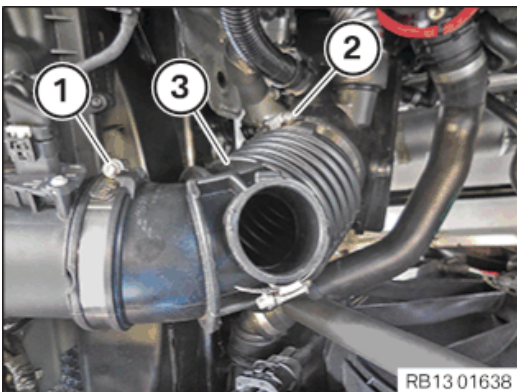

- Unfasten clamp (1).
- Unfasten clamp (2).
- Thread the top clean air pipe out (3) and remove it.

## 29 – Remove bottom clean air pipe

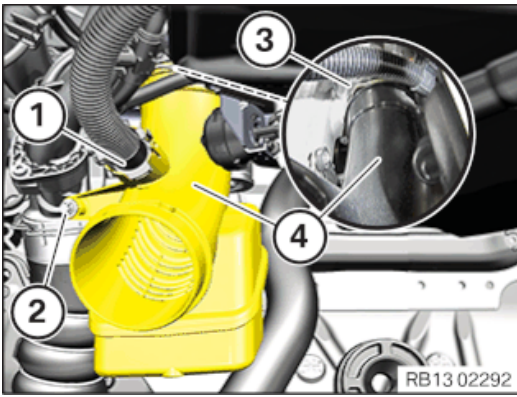

- Unlock engine ventilation line (1), disconnect it and place it aside.
- Loosen screw (2).
- Unlock and loosen clamp (3).
- Feed out the clean air pipe (4) at the bottom and remove it.

### 30 – Remove pressure pipe between exhaust turbocharger and charge air cooler

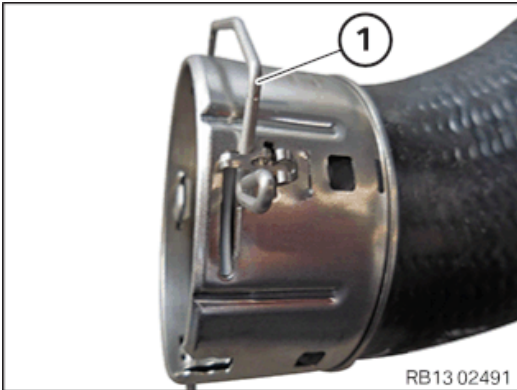

- Unlock clamp (1) and engage in this position.

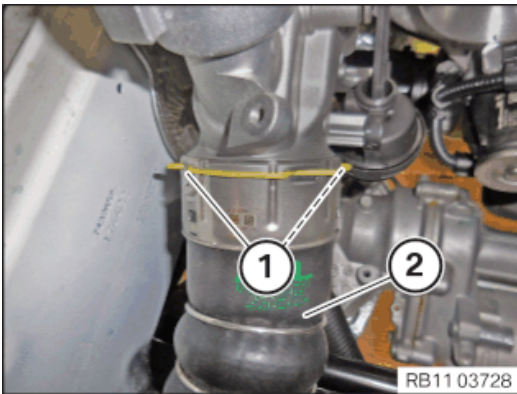

- Unlock the lock (1) and engage.
- Pull off pressure pipe (2) from the compressor bypass.

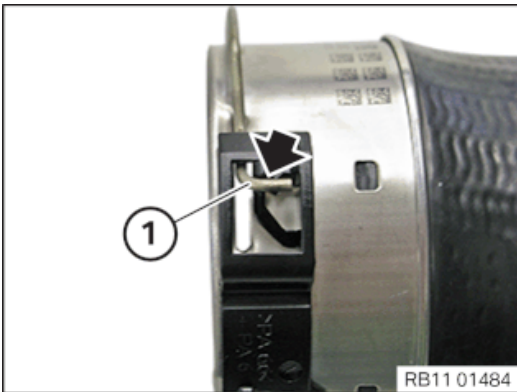

- Unlock lock (1).
- Let the lock (1) engage at the holder (arrow).

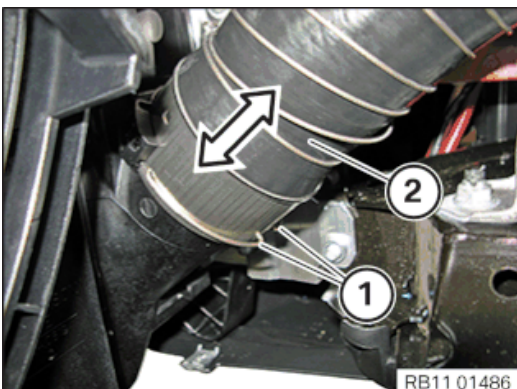

- Unlock lock (1) on both sides.
- Pull off pressure pipe (2) from charge air cooler.

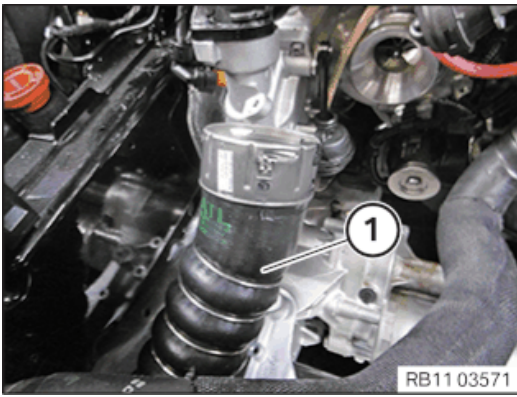

- Remove pressure pipe (1) in upward direction.

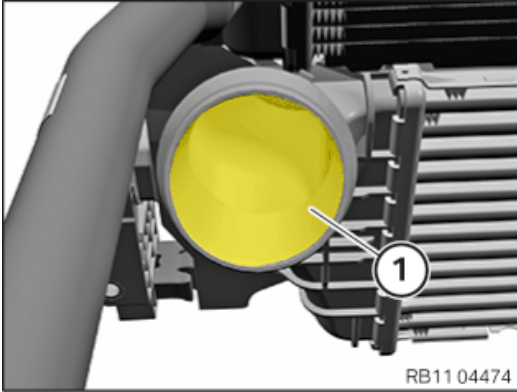

Schematic diagram is for example purposes. Some parts may differ in certain details.

- Lock the opening (1) of the charge air cooler with a suitable auxiliary material.

### 31 – Remove the pressure pipe between the throttle valve and the charge air cooler

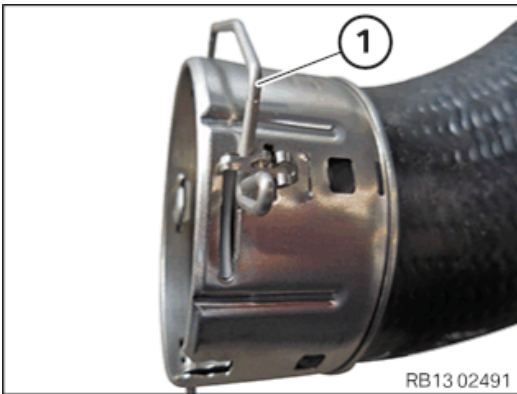

- Unlock clamp (1) and engage in this position.

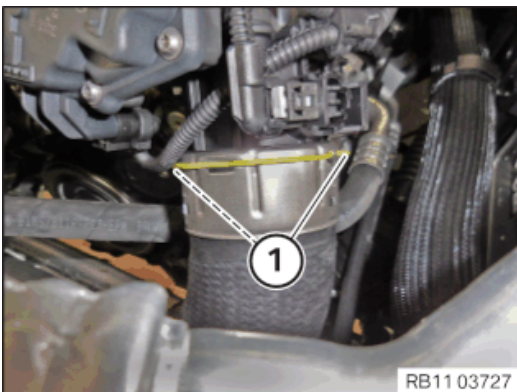

- Unlock the lock (1) and engage.
- Disconnect pressure pipe from throttle valve.

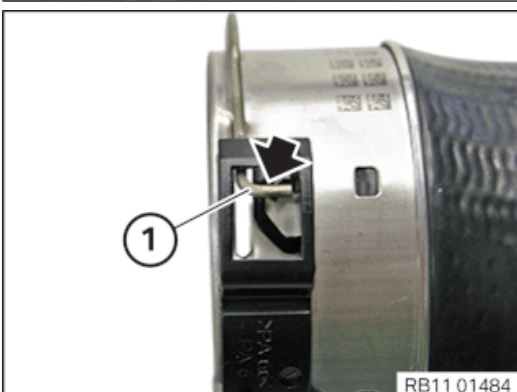

- Unlock lock (1).
- Let the lock (1) engage at the holder (arrow).

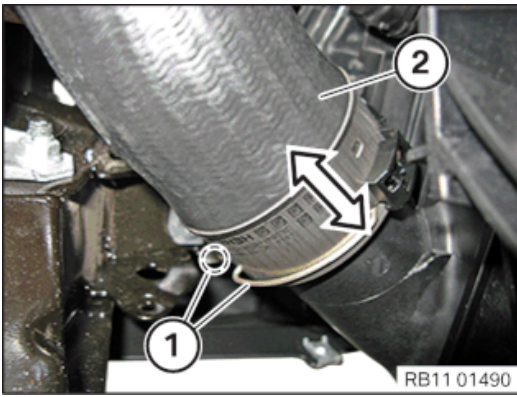

- Unlock lock (1) on both sides.
- Pull off pressure pipe (2) from charge air cooler.

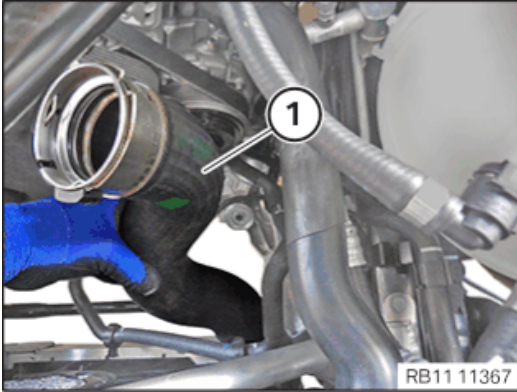

- Remove pressure pipe (1) in upward direction.

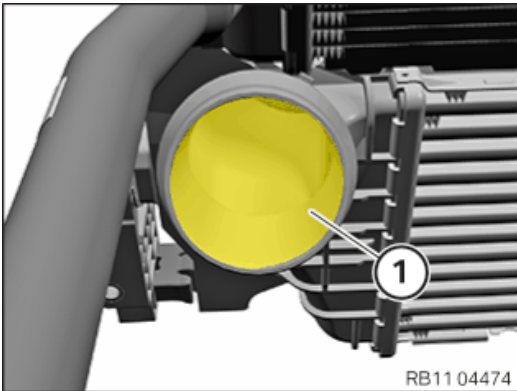

Schematic diagram is for example purposes. Some parts may differ in certain details.

- Lock the opening (1) of the charge air cooler with a suitable auxiliary material.

### 32 – Releasing air conditioning compressor

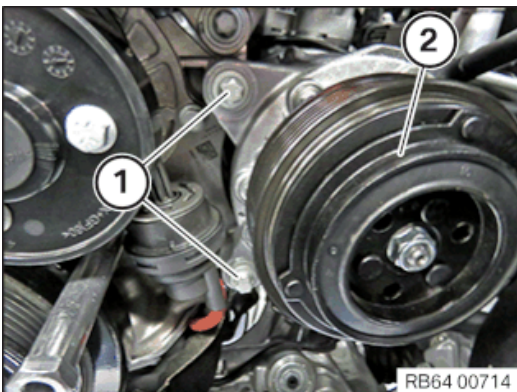

- If necessary, unlock plug connection and disconnect.
- Loosen screws (1).
- Detach the air conditioning compressor (2) from the component carrier and protect it from falling.

**Note** Tie the air conditioning compressor up.

### 33 – Remove differential pressure sensor for the diesel particulate filter



**Hot surfaces.**

**Risk of burning!**

- Perform all work only on components that have cooled down.



### Electrostatic discharge.

#### Damage to or destruction of electrical components.

- Leave electrical components in original packaging until just before they are installed. Use the original packaging only for any return shipments. Always package removed components straight away.
- Read and comply with user information on using the associated special tool 12 7 060.
- Only touch the housings of electrical components. Do not touch pins or multi-pin connectors directly.
- Wear electrically conductive clothing and antistatic shoes (with ESD symbol).
- For additional information see: 61 35 ... Notes for ESD protection (electrostatic discharge)

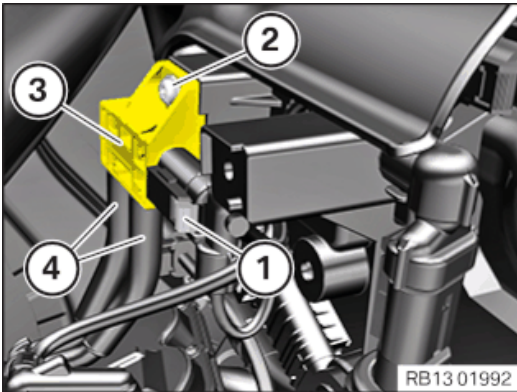

- Unlock plug connection (1) and disconnect.
- Loosen screw (2).
- Pull off pressure hose (4).
- Feed out differential pressure sensor (3) and remove.

## 34 – Remove the exhaust temperature sensor on the diesel particulate filter



### Hot surfaces.

#### Risk of burning!

- Perform all work only on components that have cooled down.



### Electrostatic discharge.

#### Damage to or destruction of electrical components.

- Leave electrical components in original packaging until just before they are installed. Use the original packaging only for any return shipments. Always package removed components straight away.
- Read and comply with user information on using the associated special tool 12 7 060.
- Only touch the housings of electrical components. Do not touch pins or multi-pin connectors directly.
- Wear electrically conductive clothing and antistatic shoes (with ESD symbol).
- For additional information see: 61 35 ... Notes for ESD protection (electrostatic discharge)

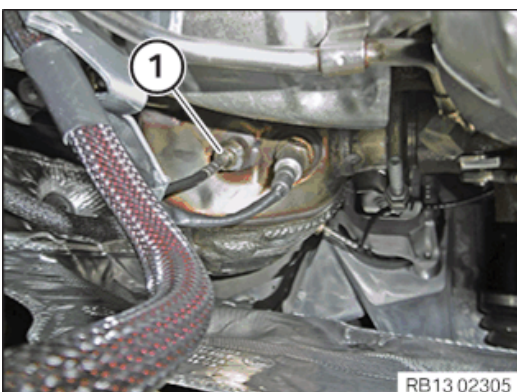

- Release exhaust temperature sensor (1) using special tool .

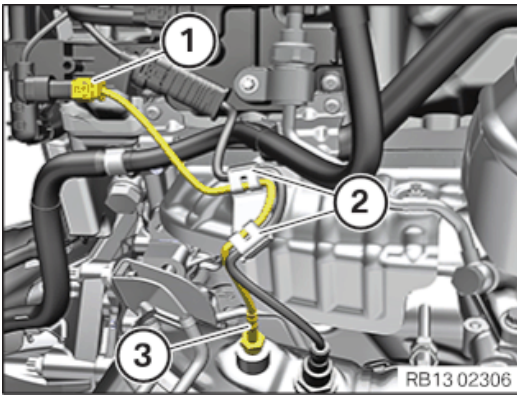

- Unlock plug connection (1) and disconnect.
- Remove the exhaust temperature sensor (3) from the clamps (2).
- Feed out and remove exhaust temperature sensor (3).

### 35 – Removing the front oxygen sensor on the diesel particulate filter on top



**Hot surfaces.**

**Risk of burning!**

- Perform all work only on components that have cooled down.



**Electrostatic discharge.**

**Damage to or destruction of electrical components.**

- Leave electrical components in original packaging until just before they are installed. Use the original packaging only for any return shipments. Always package removed components straight away.
- Read and comply with user information on using the associated special tool 12 7 060.
- Only touch the housings of electrical components. Do not touch pins or multi-pin connectors directly.
- Wear electrically conductive clothing and antistatic shoes (with ESD symbol).
- For additional information see: 61 35 ... Notes for ESD protection (electrostatic discharge)



**Damage to the front oxygen sensor or monitoring oxygen sensor.**

**Failure of the front oxygen sensor or monitoring oxygen sensor due to contamination or preliminary mechanical damage.**

- Remove the protective cap on the sensor only when screwing the sensor on to the exhaust system.
  - Do not use mounting aids, cleaning agents, gaseous and liquid agents in workplaces, storage areas and during transport.
- Contaminations (particles, dust exposure, moisture, etc.) in the area of the plug and socket connection and the sensor must be avoided.
- Mechanical loads (impacts on the sensor or the control unit, tensile loads on the cable, etc.) must be avoided.
- Do not continue using component if these specifications are deviated from.
  - The installation location (exhaust system) must be dry. If necessary, dry the installation location with compressed air.

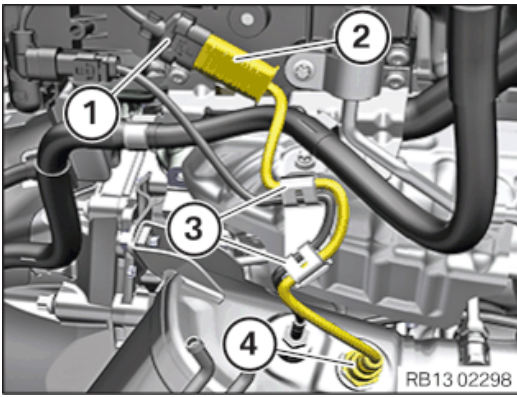

- Unlock plug connection (1) and disconnect.
- Unlock and disconnect connector (2).
- Pull the front oxygen sensor (4) out from the clamps (3) and remove it.

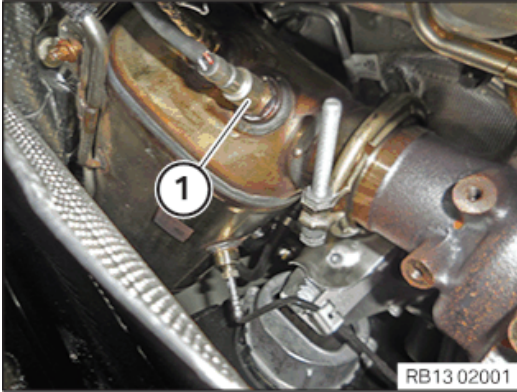

- Release the front oxygen sensor (1) with the standard tools and remove it.

### 36 – Removing the exhaust temperature sensor for the exhaust system after the catalytic converter and before the diesel particulate filter



**Hot surfaces.**

**Risk of burning!**

- Perform all work only on components that have cooled down.



**Electrostatic discharge.**

**Damage to or destruction of electrical components.**

- Leave electrical components in original packaging until just before they are installed. Use the original packaging only for any return shipments. Always package removed components straight away.
- Read and comply with user information on using the associated special tool 12 7 060.
- Only touch the housings of electrical components. Do not touch pins or multi-pin connectors directly.
- Wear electrically conductive clothing and antistatic shoes (with ESD symbol).
- For additional information see: 61 35 ... Notes for ESD protection (electrostatic discharge)

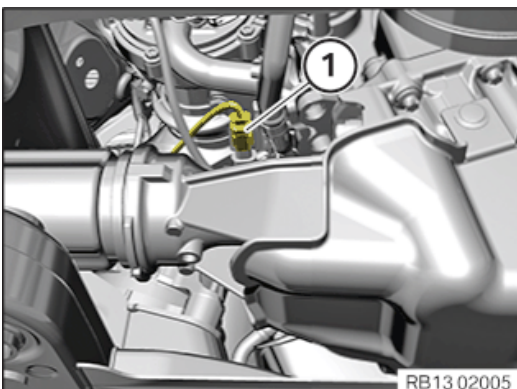

- Unlock and loosen connector (1).

**Note** The exhaust temperature sensor is located in the vicinity of the right engine mount.

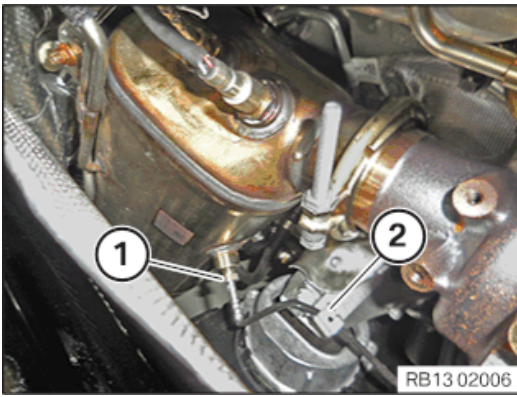

- Release the exhaust temperature sensor (1) from the clamp (2).
- Loosen exhaust temperature sensor (1).
- Feed out and remove exhaust temperature sensor (1).

### 37 – Removing the monitoring oxygen sensor after the diesel particulate filter



**Hot surfaces.**

**Risk of burning!**

- Perform all work only on components that have cooled down.



**Electrostatic discharge.**

**Damage to or destruction of electrical components.**

- Leave electrical components in original packaging until just before they are installed. Use the original packaging only for any return shipments. Always package removed components straight away.
- Read and comply with user information on using the associated special tool 12 7 060.
- Only touch the housings of electrical components. Do not touch pins or multi-pin connectors directly.
- Wear electrically conductive clothing and antistatic shoes (with ESD symbol).
- For additional information see: 61 35 ... Notes for ESD protection (electrostatic discharge)



**Damage to the front oxygen sensor or monitoring oxygen sensor.**

**Failure of the front oxygen sensor or monitoring oxygen sensor due to contamination or preliminary mechanical damage.**

- Remove the protective cap on the sensor only when screwing the sensor on to the exhaust system.
  - Do not use mounting aids, cleaning agents, gaseous and liquid agents in workplaces, storage areas and during transport.
- Contaminations (particles, dust exposure, moisture, etc.) in the area of the plug and socket connection and the sensor must be avoided.
- Mechanical loads (impacts on the sensor or the control unit, tensile loads on the cable, etc.) must be avoided.
- Do not continue using component if these specifications are deviated from.
  - The installation location (exhaust system) must be dry. If necessary, dry the installation location with compressed air.

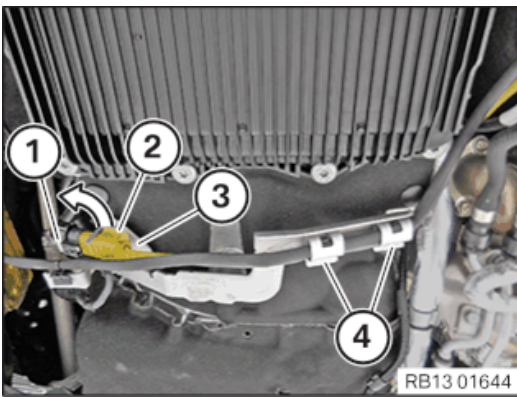

- Unlock and loosen connector (1).
- Loosen connector (2) from the holder (3) in direction of arrow.
- Release the monitoring oxygen sensor from the clamps (4).

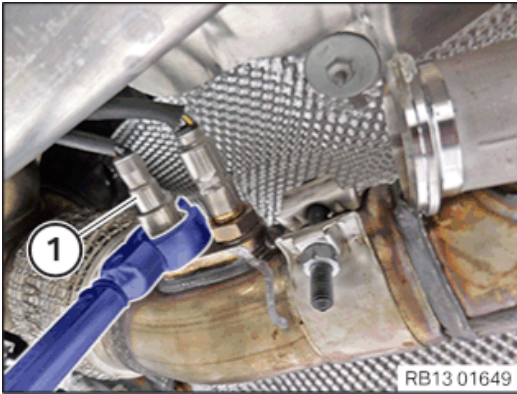

- Release the monitoring oxygen sensor (1) with the standard tools.

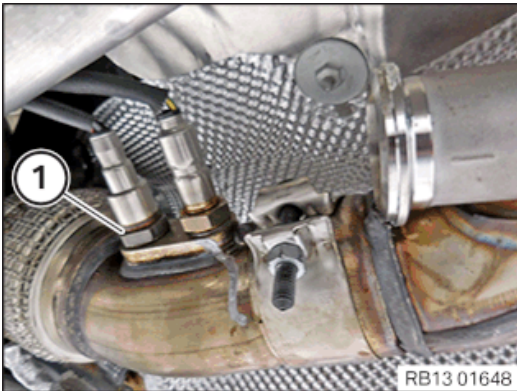

- Thread out the monitoring oxygen sensor (1) and remove it.

### 38 – Removing the nitrogen oxide sensor before SCR catalytic converter



**Hot surfaces.**

**Risk of burning!**

- Perform all work only on components that have cooled down.



**Electrostatic discharge.**

**Damage to or destruction of electrical components.**

- Leave electrical components in original packaging until just before they are installed. Use the original packaging only for any return shipments. Always package removed components straight away.
- Read and comply with user information on using the associated special tool 12 7 060.
- Only touch the housings of electrical components. Do not touch pins or multi-pin connectors directly.
- Wear electrically conductive clothing and antistatic shoes (with ESD symbol).
- For additional information see: 61 35 ... Notes for ESD protection (electrostatic discharge)



## Damage to the nitrogen oxide sensor.

### Failure of the nitrogen oxide sensor due to contamination or preliminary mechanical damage.

- Remove the protective cap on the sensor only when screwing the sensor on to the exhaust system.
  - Do not use mounting aids, cleaning agents, gaseous and liquid agents in workplaces, storage areas and during transport.
- Contaminations (particles, dust exposure, moisture, etc.) in the area of the plug and socket connection and the sensor must be avoided.
- Mechanical loads (impacts on the sensor or the control unit, tensile loads on the cable, etc.) must be avoided.
- Do not continue using component if these specifications are deviated from.
  - The installation location (exhaust system) must be dry. If necessary, dry the installation location with compressed air.

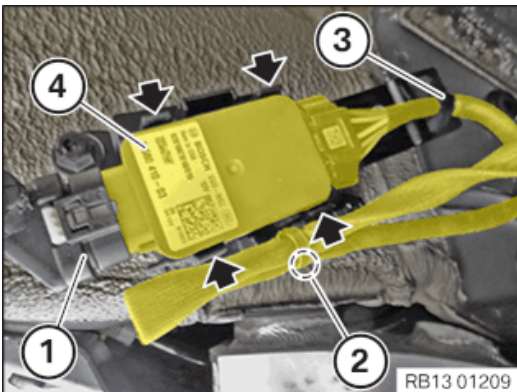

- Unlock plug connection (1) and disconnect.
- Release cable clip in area (2).
- Release line from the holder (3).
- Unclip control unit (4).

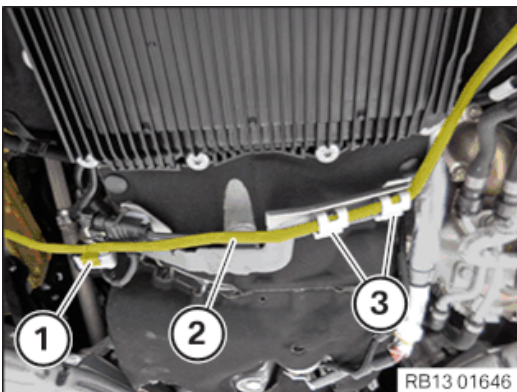

- Loosen clamp (1).
- Loosen the cables (2) from the clamps (3).

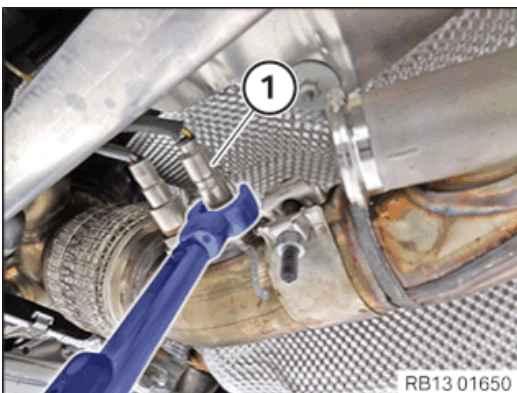

- Loosen the nitrogen oxide sensor (1) using commercially available tools.

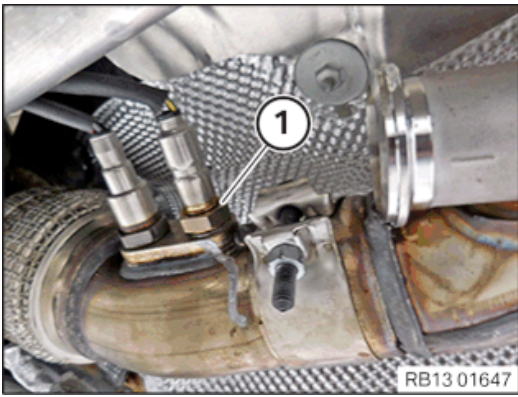

- Feed out and remove the nitrogen oxide sensor (1).

### 39 – Remove tank cover on left and right



The description is for one component only. The procedure is identical for all further components.

#### ► Removing the tank cover

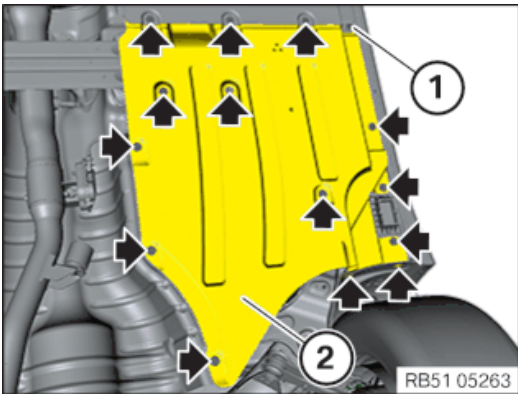

- Release the plastic nut (1).
- Release all bolts (arrows).
- Guide out and remove the tank cover (2) .

### 40 – Remove the connecting support from the tunnel

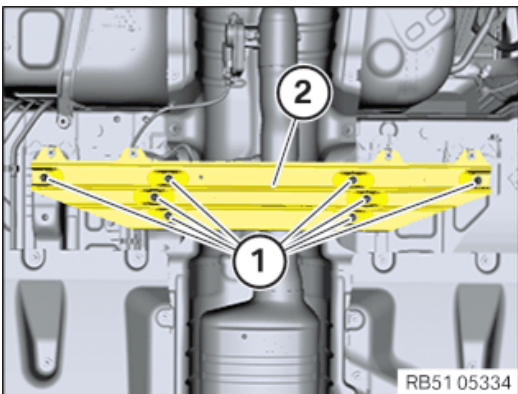

- Loosen screws (1).
- Remove the connecting support (2) at the tunnel.

### 41 – Remove exhaust system



**Hot surfaces.**

**Risk of burning!**

- Perform all work only on components that have cooled down.



### Component with heavy weight.

#### Danger of injury!

- Note component's centre of gravity.
- Support component using a jack.
- Secure component against falling off the jack.



### Heavy component.

#### Heavy components can lead to injury or damage.

- Remove and install heavy components with the aid of another person/other persons.

### ► If installed: Remove the right torsion strut



Driving without a torsion strut is not permitted.

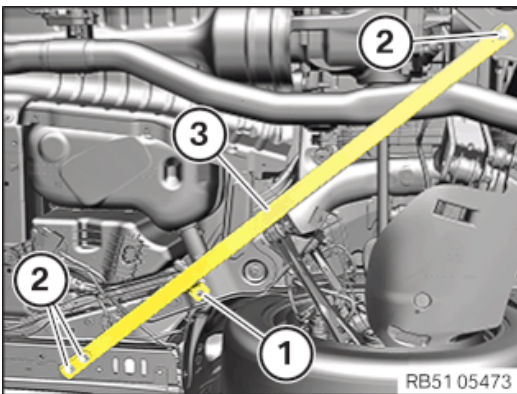

- Unfasten nut (1).
- Loosen screws (2).
- Thread out torsion strut (3) at right and remove.

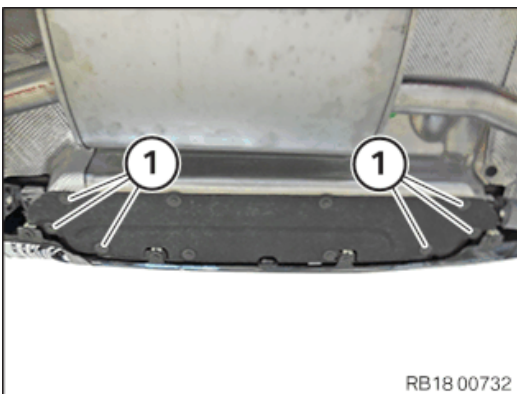

- Loosen screws (1).
- Partially detach the cover.

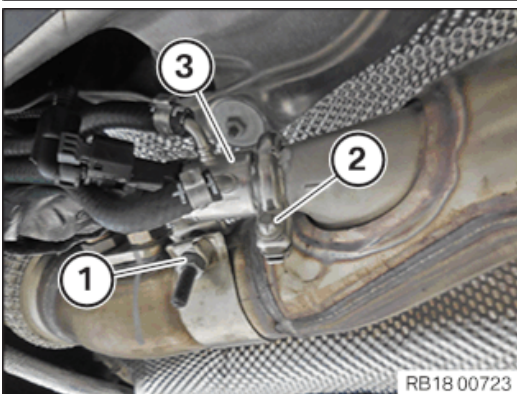

- Unfasten clamp (1).
- Detach the clamp (2) of the SCR metering module (3).
- Release the SCR metering module (3) from the exhaust system and set aside.

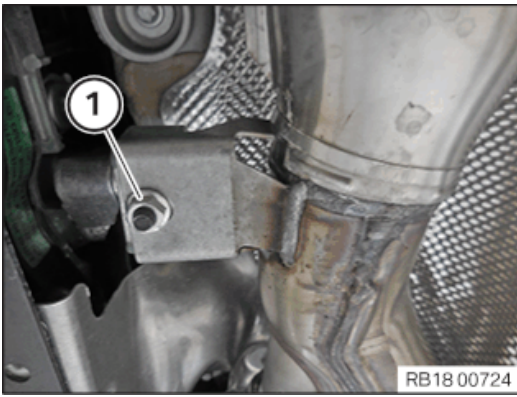

- Loosen nut (1).

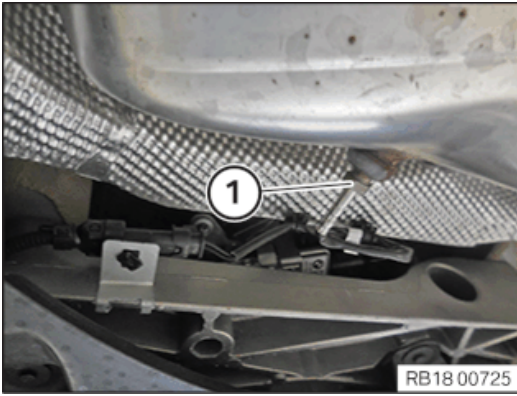

- Detach the exhaust temperature sensor (1) from the exhaust system.

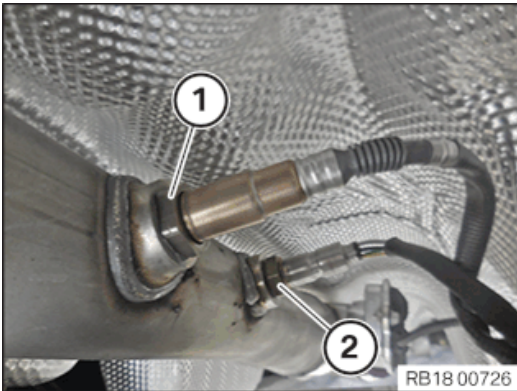

- Release the diesel particulate sensor (1)x from the exhaust system and set aside.
- Release the nitrogen oxide sensor (2) from the exhaust system and place to one side.

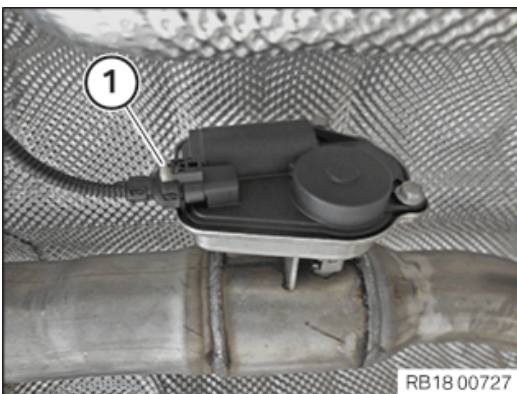

The following work step(s) is / are to be carried out if the specified component(s) is/are fitted.

- Unlock plug connection (1) and disconnect.

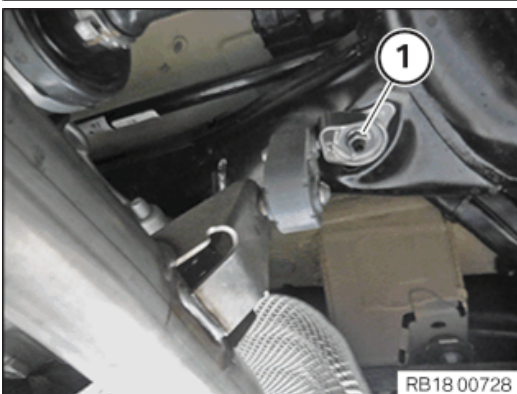

- Loosen nut (1).

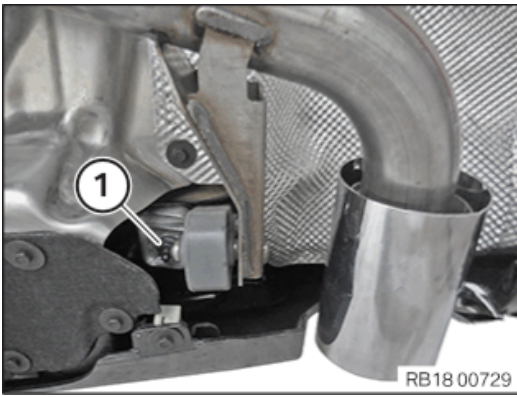

- Loosen nut (1).

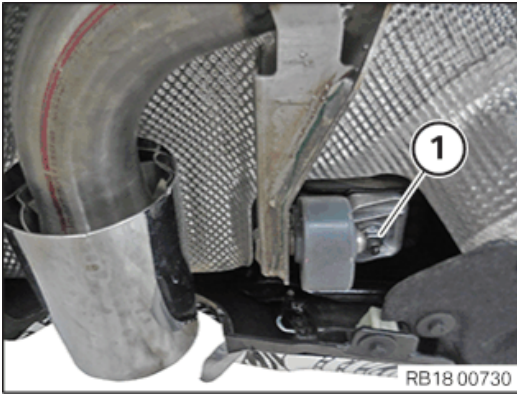

- Loosen nut (1).
- Lower the exhaust system with an auxiliary person, guide out and remove.

## 42 – Removing the diesel particulate filter



**Hot surfaces.**

**Risk of burning!**

- Perform all work only on components that have cooled down.



**Heavy component.**

**Heavy components can lead to injury or damage.**

- Remove and install heavy components with the aid of another person/other persons.

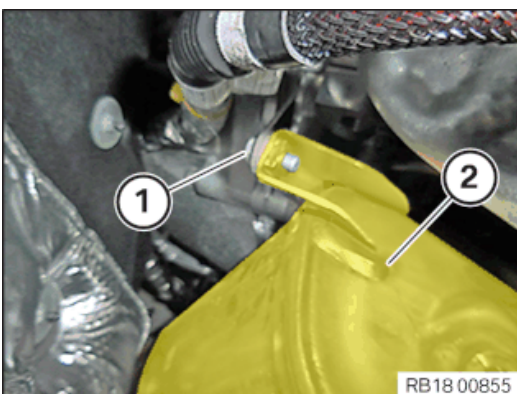

- Release bolt (1) from the holder of diesel particulate filter (2).

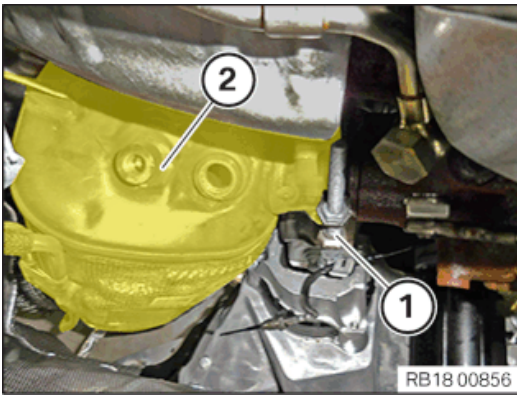

- Loosen V-band clamp (1).
- Feed V-clip (1) out from diesel particulate filter (2) and remove.

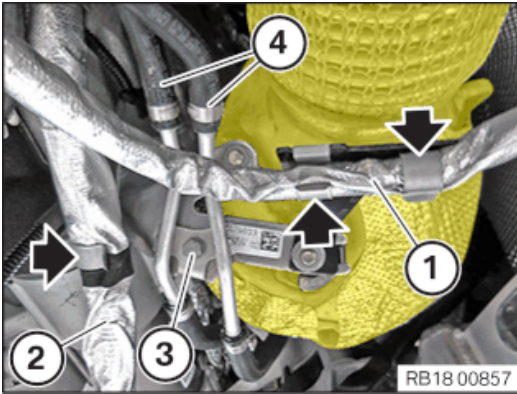

- Release the metering line (1) from clamps (Arrows).
- Release positive battery cable (2) from starter motor from clamp (Arrow).
- Loosen screw (3).
- Thread off coolant line (4) and place to the side.

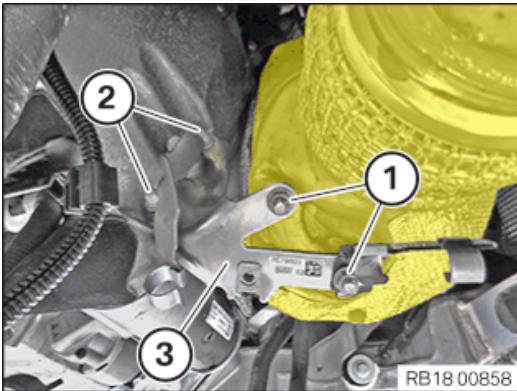

- Loosen nuts (1).
- Loosen screws (2).
- Guide out and remove holder (3).

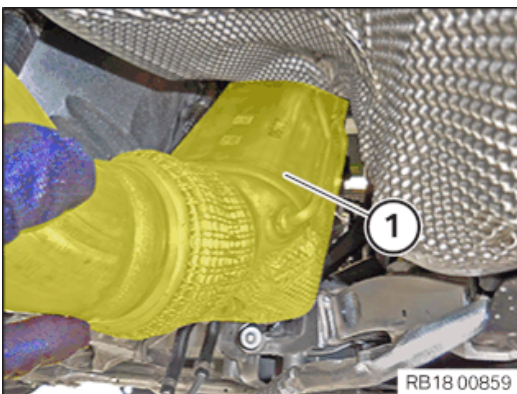

- Guide out and remove diesel particulate filter (1).

#### 43 – Remove the cover of the DDE control unit

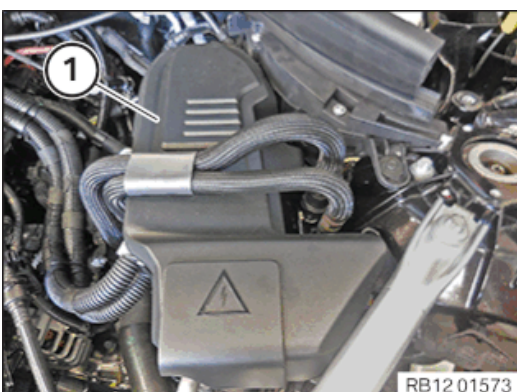

- Pull the cover (1) of the DDE control unit up and out of the rubber mounts, guide it out and remove.

## 44 – Remove DDE control unit



### Electrostatic discharge.

#### Damage to or destruction of electrical components.

- Leave electrical components in original packaging until just before they are installed. Use the original packaging only for any return shipments. Always package removed components straight away.
- Read and comply with user information on using the associated special tool 12 7 060.
- Only touch the housings of electrical components. Do not touch pins or multi-pin connectors directly.
- Wear electrically conductive clothing and antistatic shoes (with ESD symbol).
- For additional information see: 61 35 ... Notes for ESD protection (electrostatic discharge)



In a warranty case, you must always provide a fault memory printout with the defective part, even if the fault memory does not contain an entry.



Follow instructions for removing and installing control units.

For additional information see: 12 00 ... Notes on removal and installation of control units



Disconnecting control units may cause fault code entries and functional limitations. Fault code entries must be read out and deleted if necessary.



Control unit must be programmed after it is replaced.

For additional information see: 61 00 ... Programming/encoding control unit(s)

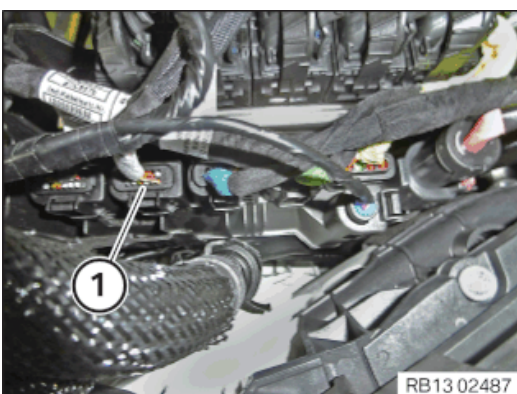

- Unlock plug connection (1) and disconnect.

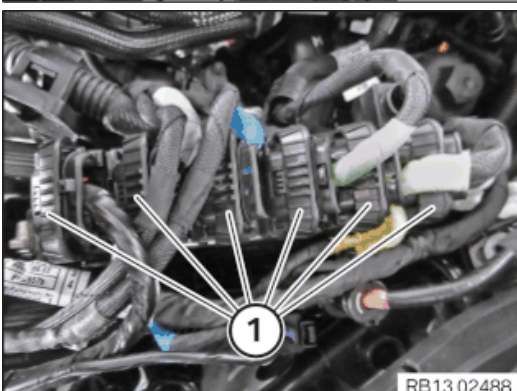

- Unlock and disconnect plug connections (1).

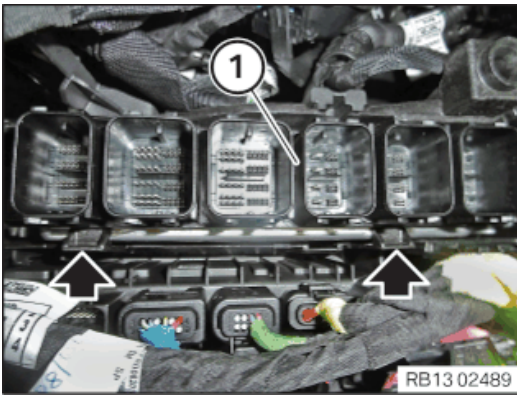

- Release the latch mechanisms (arrows).
- Thread out and remove DDE control unit (1).

#### 45 – Removing integrated supply module (PDM)



##### **Electrostatic discharge.**

##### **Damage to or destruction of electrical components.**

- Leave electrical components in original packaging until just before they are installed. Use the original packaging only for any return shipments. Always package removed components straight away.
- Read and comply with user information on using the associated special tool 12 7 060.
- Only touch the housings of electrical components. Do not touch pins or multi-pin connectors directly.
- Wear electrically conductive clothing and antistatic shoes (with ESD symbol).
- For additional information see: 61 35 ... Notes for ESD protection (electrostatic discharge)

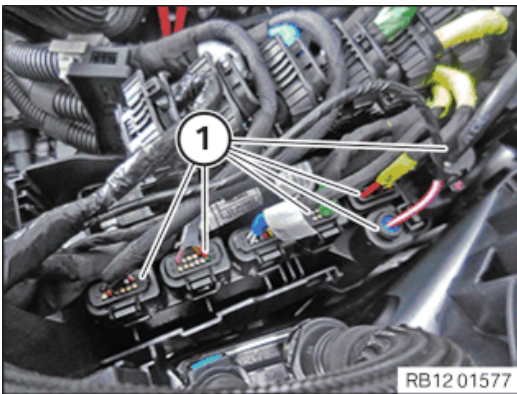

- Unlock plug connections (1) and disconnect.

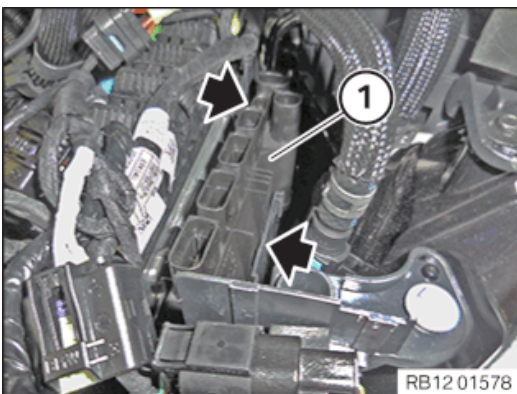

- Unlock the locks (arrows).
- Feed out and remove the integrated supply module (PDM) (1).

#### 46 – Remove the holder for the DDE control unit

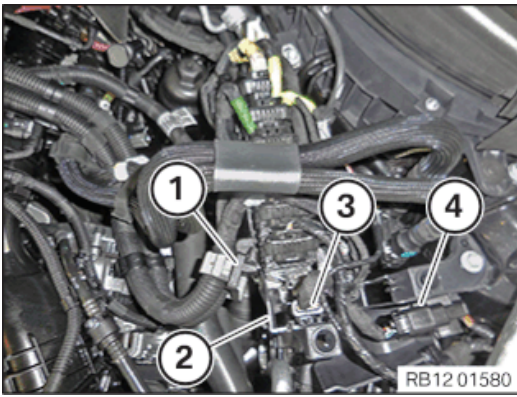

- Unlock the cable clip (1) and release it from the holder (2) for the DDE control unit.
- Unlock plug connection (3) and disconnect.
- Unlock the connector (3) and release it from the holder (2) for the DDE control unit.
- Unlock plug connection (4) and disconnect.
- Unlock the connector (4) and release it from the holder (2) for the DDE control unit.

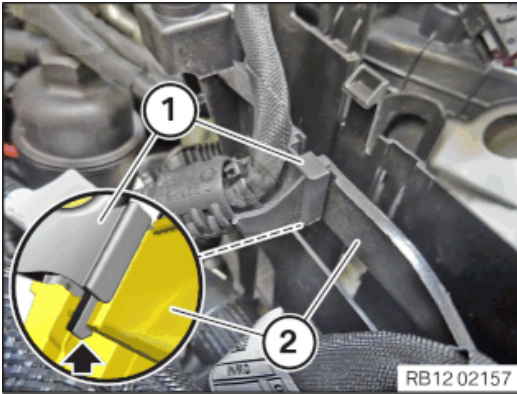

- Unlock the lock (arrow).
- Disconnect the cable holder (1) upwards from the control unit holder (2).

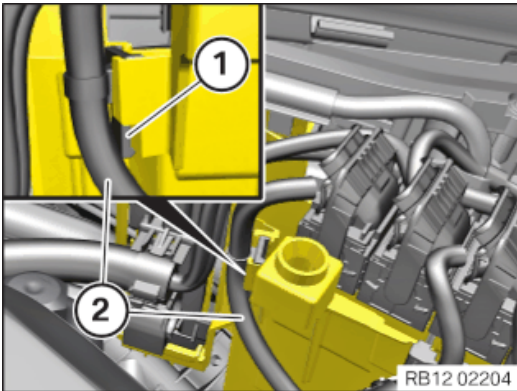

- Unlock and loosen the cable clip (1).
- Remove the wiring harness section (2) and put to one side.

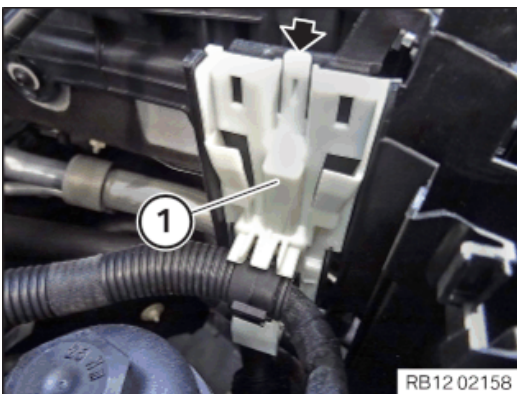

- Unlock the lock (arrow).
- Feed out the cable clip (1) upwards and set it aside.

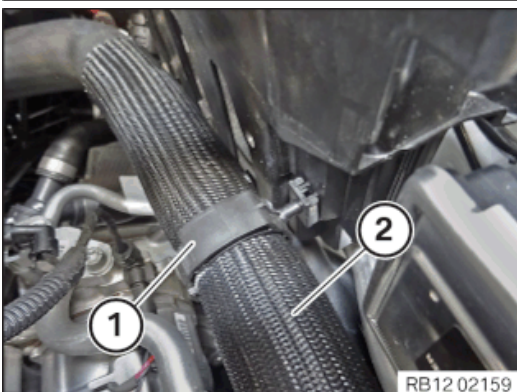

- Unlock the holder (1) and feed the coolant line (2) out and set it aside.

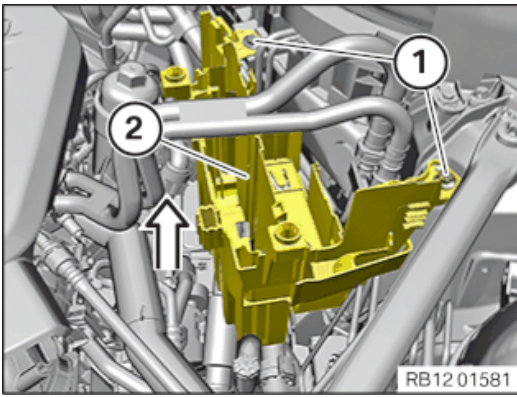

- Loosen screws (1).
- Feed out the holder (2) for the DDE control unit in an upwards direction of arrow and remove it.

#### 47 – Releasing the oil drain plug



**Hot fluids.**

**Risk of scalding!**

- Conduct all work in the vehicle wearing appropriate personal protective equipment only.

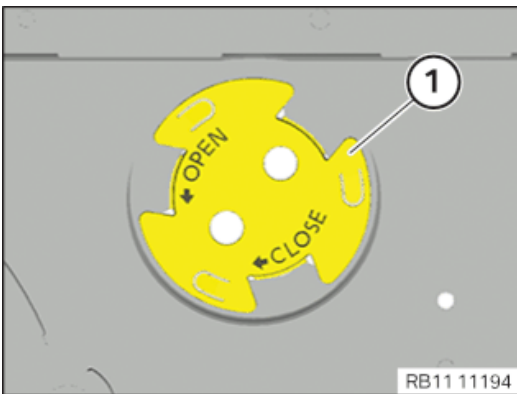

- Turn and remove service cap (1).

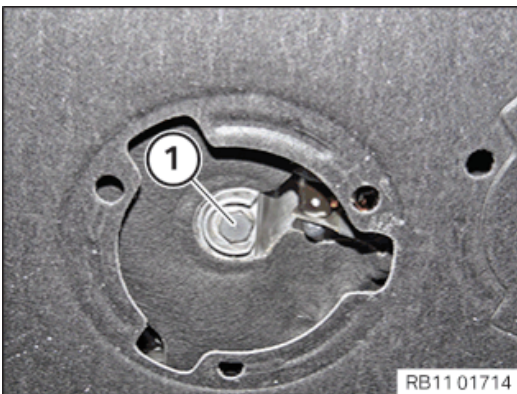

- Open oil drain plug (1) from the oil sump.



Collect and dispose of emerging fluids. Observe country-specific waste disposal regulations.

- Allow the engine oil to drain out fully.

#### 48 – Tightening the oil drain plug

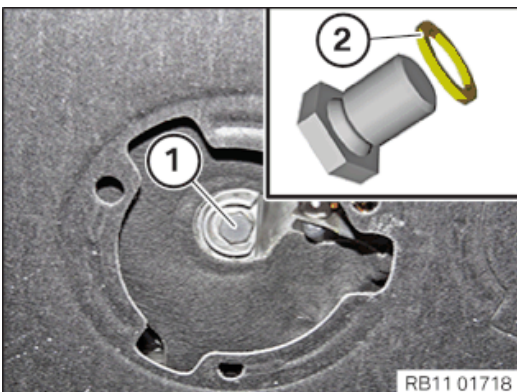

- Renew sealing ring (2).
- Position oil drain plug (1) on the oil sump and tighten.

#### Oil drain plug

M12x16	Renew the sealing ring.	Tightening torque	25 Nm
--------	-------------------------	-------------------	-------

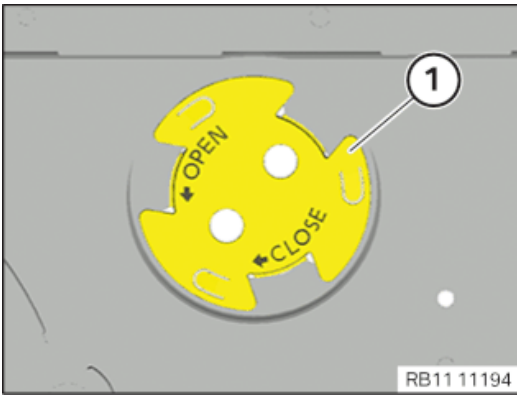

- Install service cap (1).

#### 49 – Remove the heat shield

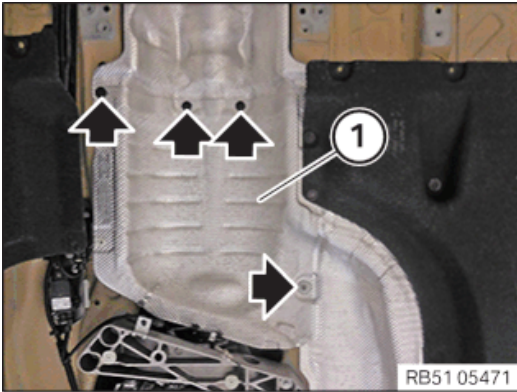

- Loosen bolts and nuts (arrows).
- Remove the heat shield (1).

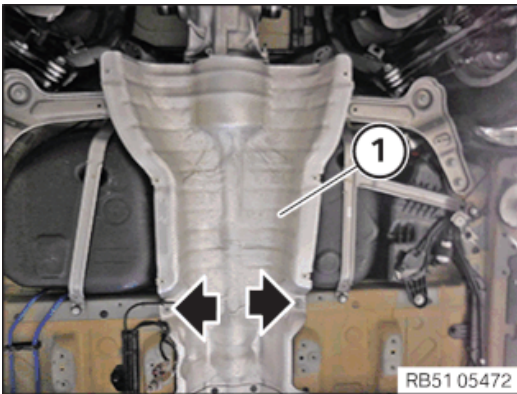

- Loosen bolts and nuts (arrows).
- Remove the heat shield (1).

#### 50 – Remove the retaining plates

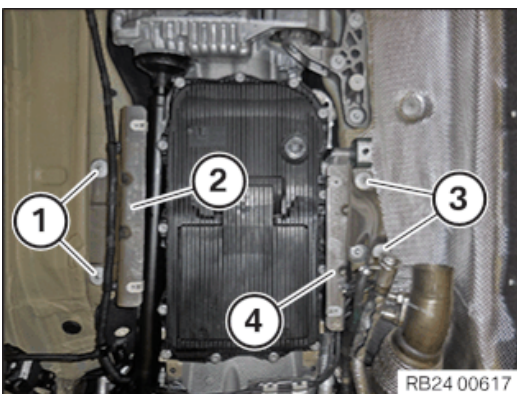

- Loosen nuts (1) and (3).
- Remove retaining plates (2) and (4).

#### 51 – Partially releasing propeller shaft



### Damage to propeller shaft during removal.

**Non-observance of the removal guidelines for the propeller shaft on the rear axle differential may cause severe damage.**

- Do not disassemble the three-hole flange, flexible disc and propeller shaft. The three-hole flange to the rear axle differential is balanced with the flexible disc and propeller shaft.
- Loosen the recessed nut against the direction of travel in clockwise direction. The propeller shaft must be loosened on the recessed nut only and exclusively in the direction of rotation otherwise the anti-twist lock of the bi-hexagonal flange nut is damaged.
- In the event of a damaged anti-twist lock on the bi-hexagonal flange nut: Replace the rear axle differential.

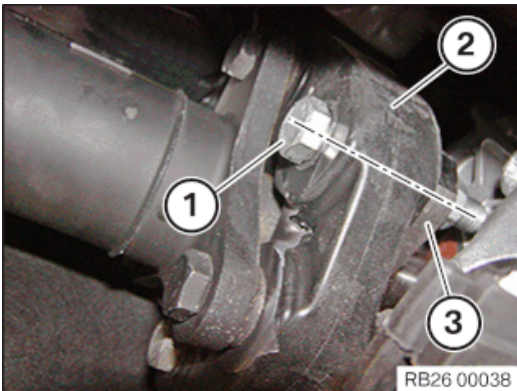

- Mark installation position of screw connection (1) of flexible disc (2) and of three-hole flange (3).

The mark makes it possible for the propeller shaft to be installed again in the same position. This should prevent a humming noise from the drive train during driving.

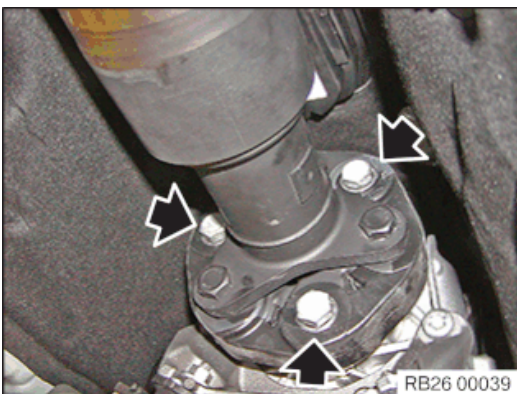

- Remove screws (arrows).

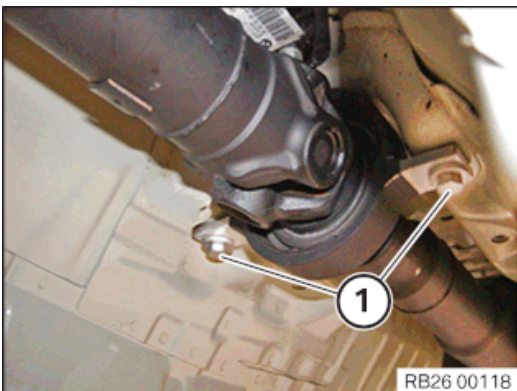

- Unscrew the bolts (1) on the centre mount and hold down the propeller shaft.  
Major deflection angles of the propeller shaft may damage the propeller shaft and/or the joints.
- Tie up propeller shaft to underbody.

## 52 – Removing starter motor

### ► Removing the starter in vehicles with four-wheel drive

#### Prerequisite

Battery earth leads are disconnected.



### Hot surfaces.

#### Risk of burning!

- Perform all work only on components that have cooled down.



### Working on 12 V vehicle electrical system.

#### Risk of short circuits! Risk of fire!

- Make sure that **no charger** is connected to the jump start support point in the engine compartment.
- Detach battery earth lead from battery.
- With auxiliary batteries: Detach all battery earth leads from additional batteries.



Make sure that the acoustic cover is **not** damaged while removing the starter motor.

A damaged lower acoustic cover can only be renewed when the front axle is lowered.

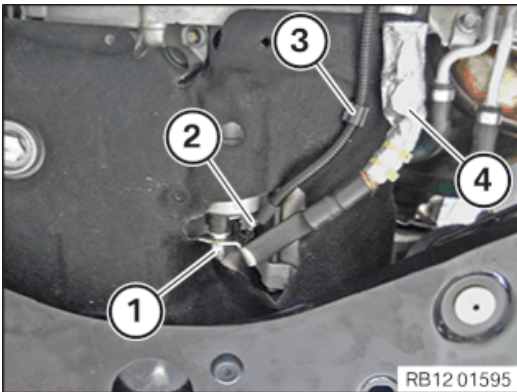

#### • Version A:

Unscrew the nut (1) and remove the positive battery cable from the starter motor.

Unscrew the nut (2) and disconnect the cable (terminal 50) from the starter motor.

Release the clamp (3) and put the cable to one side.

Release the positive battery cable from the clamp (4) and set aside.

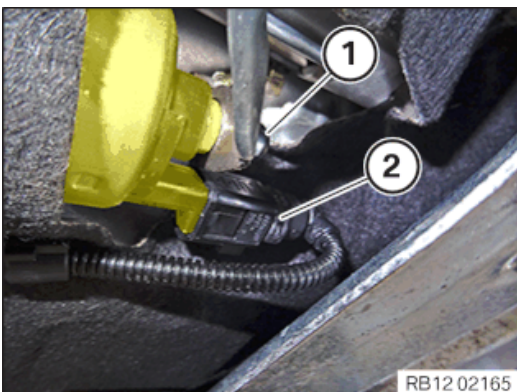

#### • Version B:

Loosen nut (1).

Unlock plug connection (2) and disconnect.

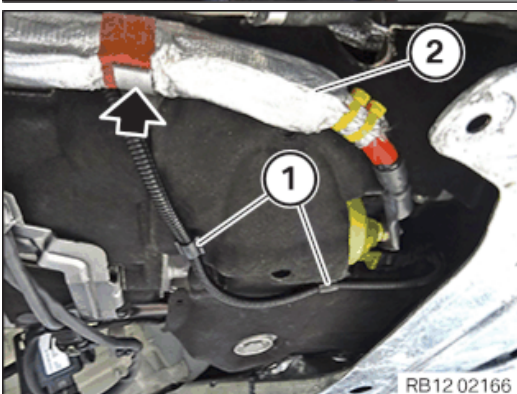

- Loosen clamps (1).

- Feed the positive battery cable (2) out of holder (Arrow) and place aside.

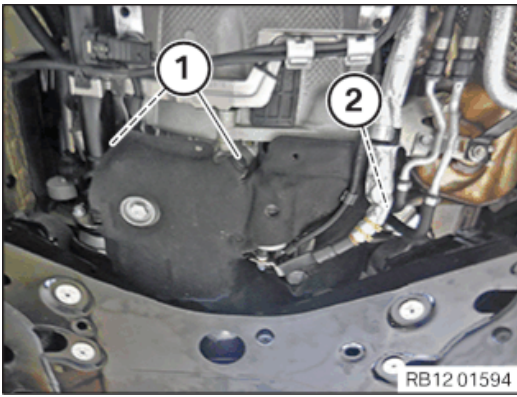

- Release the rear expanding rivet (1) from the acoustic cover.
- Loosen clip (2).

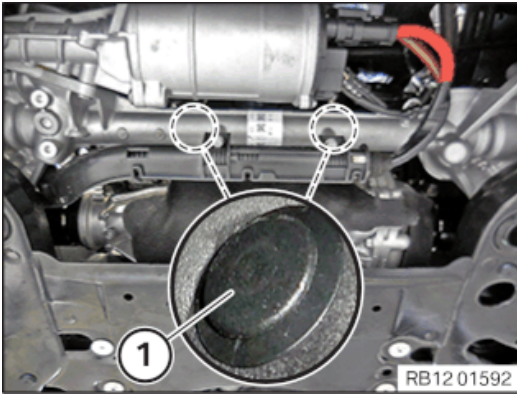

- Release the front expanding rivet (1) from the acoustic cover.

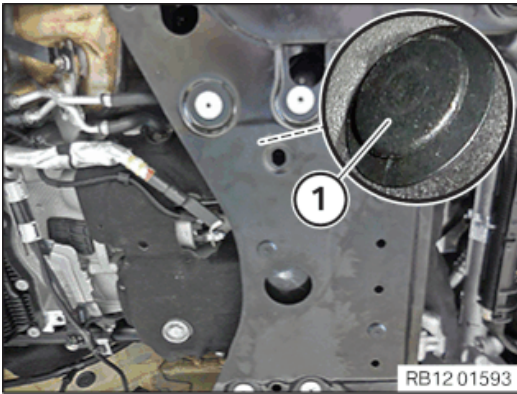

- Release the centre expanding rivet (1) from the acoustic cover.

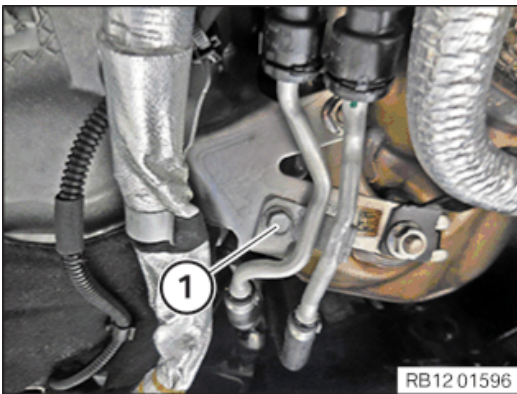

- Loosen screw (1).

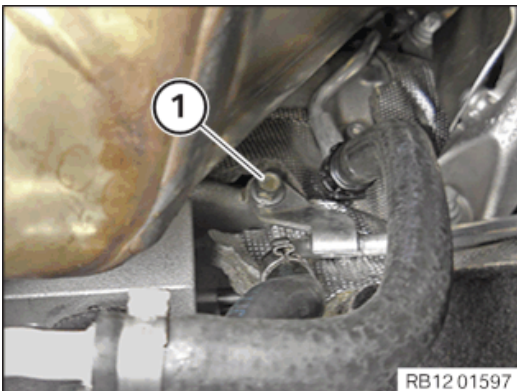

- Release the screw (1) and put the coolant lines to one side.

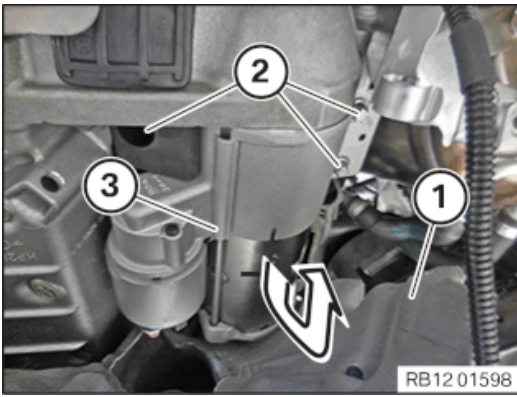

- Make sure that the acoustic cover (1) is not damaged.
- Carefully press the acoustic cover (1) to one side.
- Loosen screws (2).
- Carefully guide out the starter motor (3) in direction of arrow and remove.

### ► Removing the starter motor on vehicles with rear-wheel drive

#### Prerequisite

Battery earth leads are disconnected.



**Hot surfaces.**

**Risk of burning!**

- Perform all work only on components that have cooled down.



**Working on 12 V vehicle electrical system.**

**Risk of short circuits! Risk of fire!**

- Make sure that **no charger** is connected to the jump start support point in the engine compartment.
- Detach battery earth lead from battery.
- With auxiliary batteries: Detach all battery earth leads from additional batteries.



Make sure that the acoustic cover is **not** damaged while removing the starter motor.

A damaged lower acoustic cover can only be renewed when the front axle is lowered.

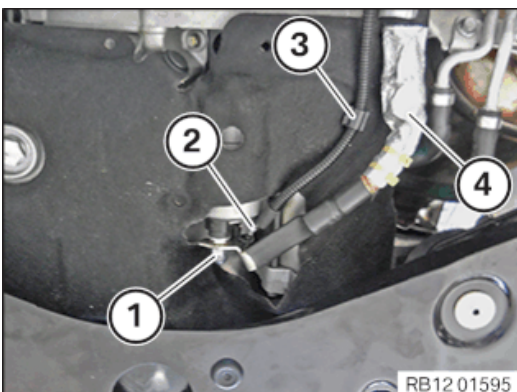

#### • **Version A:**

Unscrew the nut (1) and remove the positive battery cable from the starter motor.

Unscrew the nut (2) and disconnect the cable (terminal 50) from the starter motor.

Release the clamp (3) and put the cable to one side.

Release the positive battery cable from the clamp (4) and set it aside.

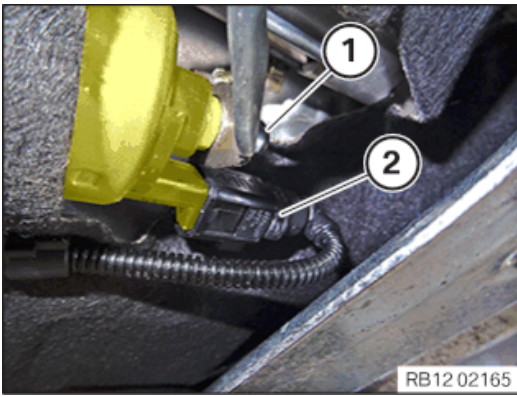

- **Version B:**  
Loosen nut (1).  
Unlock plug connection (2) and disconnect.

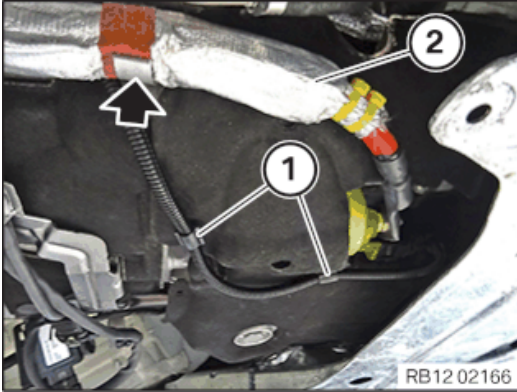

- Loosen clamps (1).
- Feed the positive battery cable (2) out of holder (Arrow) and place aside.

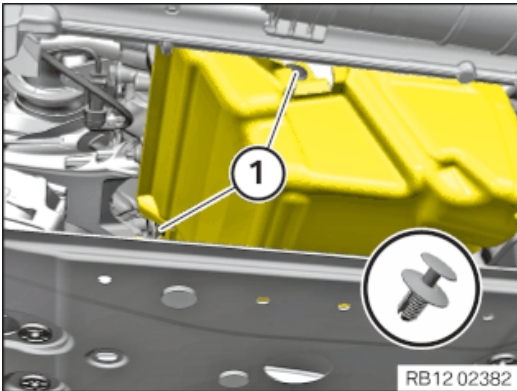

- Release the expanding rivet (1).

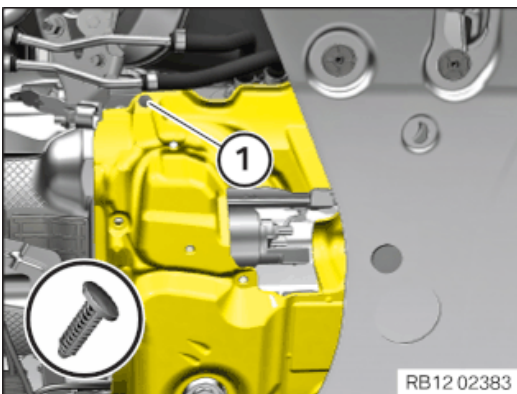

- Undo Christmas tree clip (1).

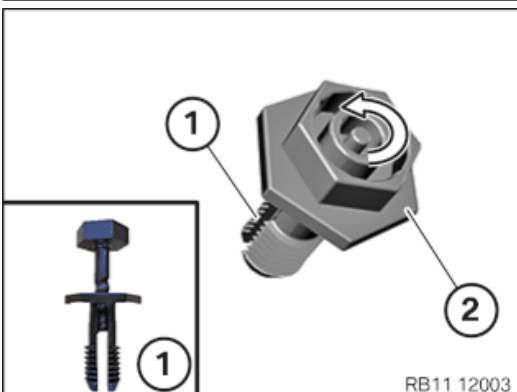

- Hold down expanding rivet (1) on the left side in area (2) and release it by turning it in the direction of the arrow.

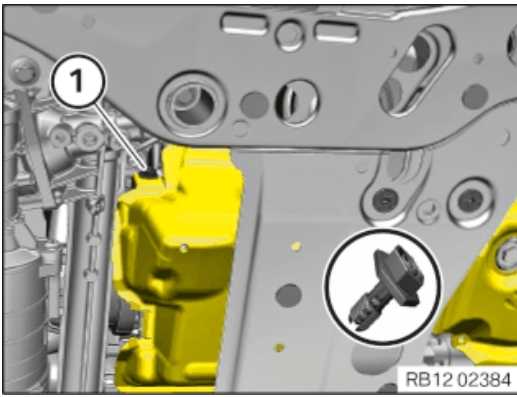

- Release expanding rivet (1).

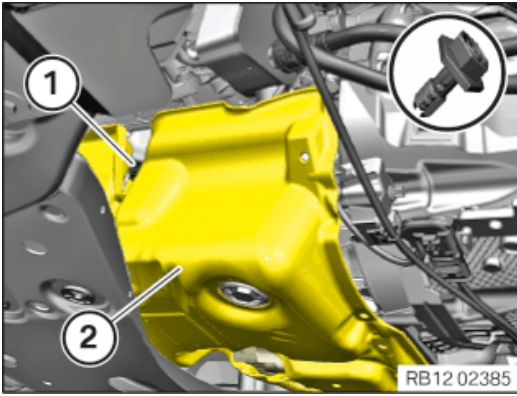

- Loosen expanding rivet (1).
- Feed out the oil sump acoustic cover (2) and place aside.

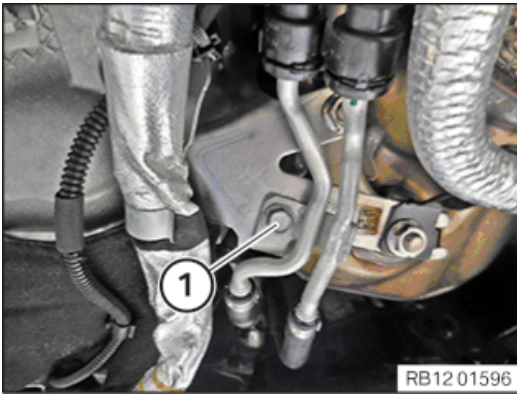

- Loosen screw (1).

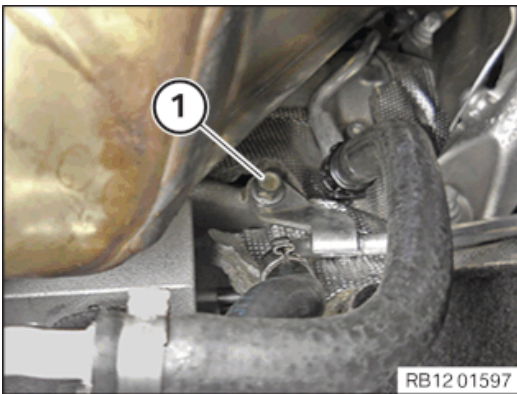

- Release the screw (1) and put the coolant lines to one side.

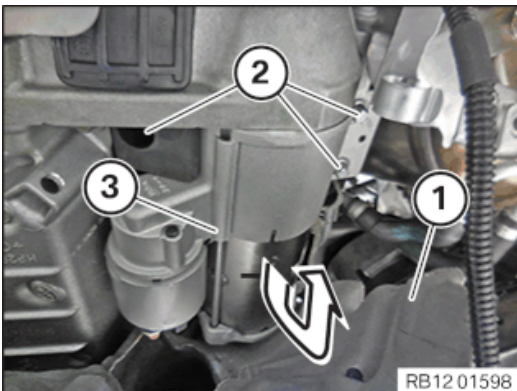

- Make sure that the acoustic cover (1) is not damaged.
- Carefully press the acoustic cover (1) to one side.
- Loosen screws (2).
- Carefully guide out the starter motor (3) in direction of arrow and remove.

### 53 – Remove automatic transmission (GA8HP51Z)



### Materials harmful to health.

#### Contact with fluids harmful to health!

- Note and follow safety information on containers.
- Conduct all work in appropriate personal protective equipment only.



### Damage to the engine block.

#### Serious damage to the engine block and transmission due to damaged and corroded bolts.

- It is imperative that protruding threads of the transmission bolts are checked for corrosion and damage prior to removal.
- It is imperative that all rust is removed from corroded threads and that they are cleaned prior to removal.
- Renew rusted and damaged bolts.



### Damage of components in the engine compartment.

#### When removing the transmission, tilting of the engine may damage components in the engine compartment.

- Before removing the transmission: Support engine.
- Secure the engine against tilt movements.
- Follow the specifications of the repair instructions.



### Damage to the transmission.

#### Damage to the transmission by unapproved transmission oil.

- Use only the approved transmission oil.
- Check the transmission oil level after completing the repair.

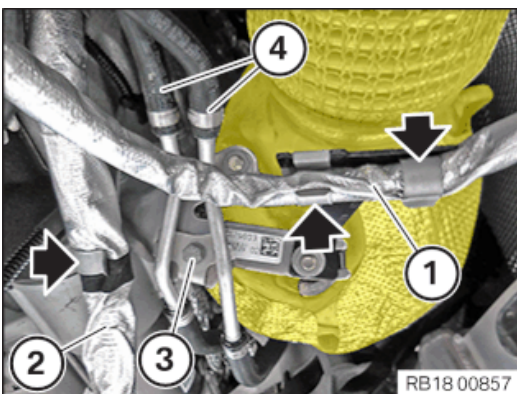

- Release the metering line (1) from clamps (Arrows).
- Release positive battery cable (2) from starter motor from clamp (Arrow).
- Loosen screws (3).
- Thread off coolant line (4) and place to the side.

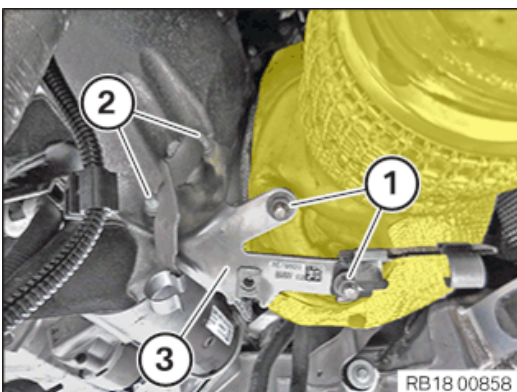

- Loosen nuts (1).
- Loosen screws (2).
- Guide out and remove holder (3).

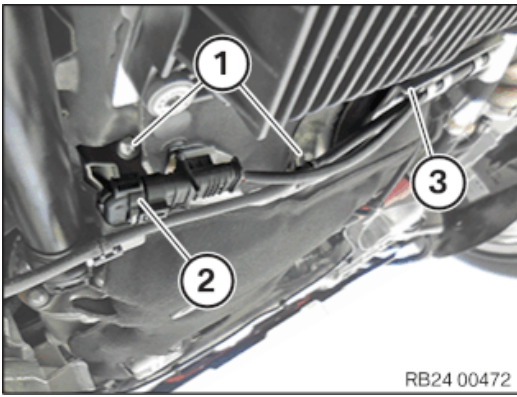

- Loosen screws (1).
- Disconnect the connector (2) .
- Remove holder (3).

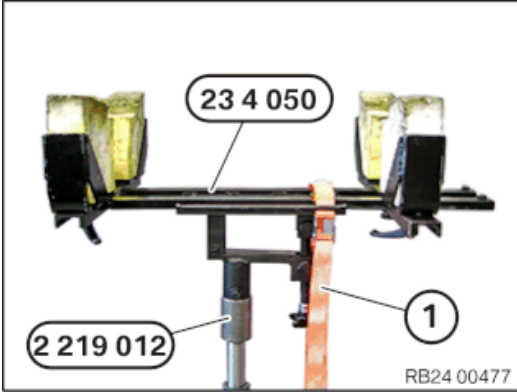

- Support the transmission using special tools **2 219 012** and **0 495 498 (23 4 050)**.
- Secure the transmission with the tensioning strap (1).

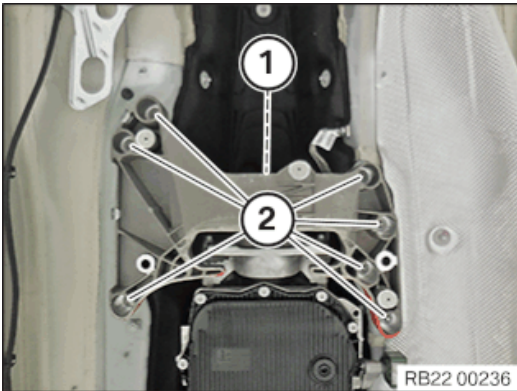

- Loosen screw (1).
- Loosen screws (2).
- Remove transmission cross member.

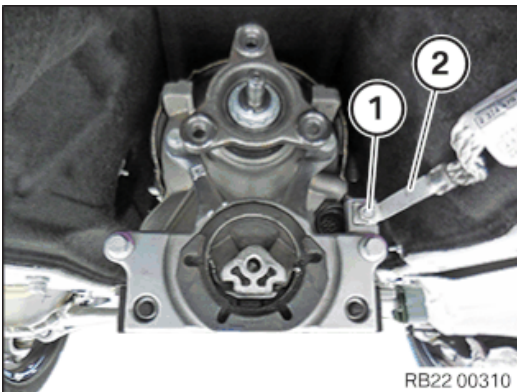

- Unscrew the bolt (1) and disconnect the ground strap (2).

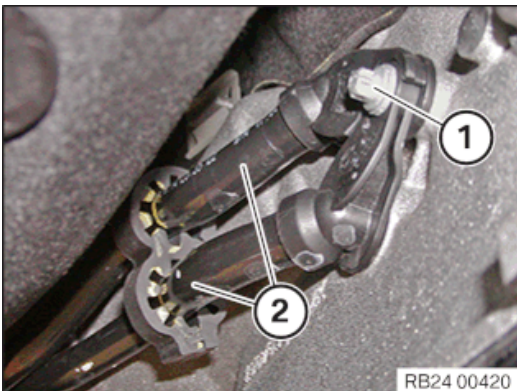

- Loosen screw (1).
- Disconnect hydraulic lines (2) to transmission oil cooler.

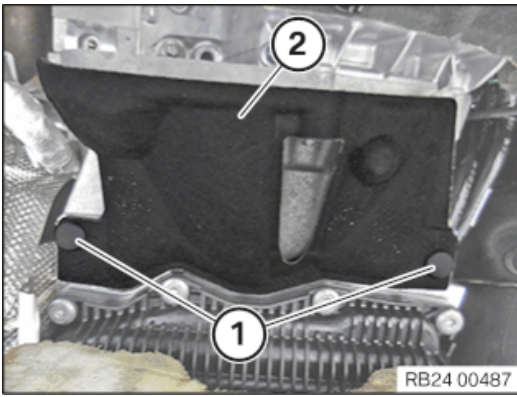

- Pull the expanding rivet (1) off.
- Remove the acoustic cover (2).

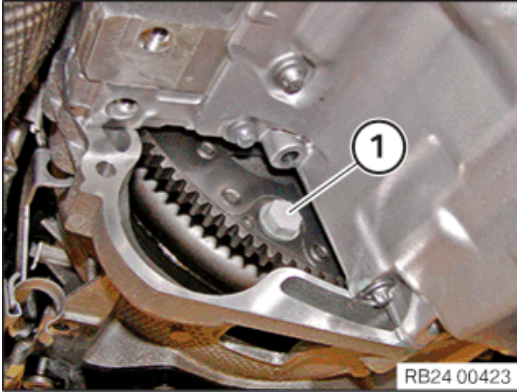

**Only G05 and G07**

In vehicles with active anti-roll bar (ARS) the fan cowl must be removed in order to spin the engine.

For additional information see: 17 11 035 Removing and installing/replacing the fan cowl including electric fan

- Turn the engine on the vibration damper with the special tool **0 493 380 (11 6 480)** in the direction of rotation until the bolt (1) becomes visible in the recess.
- Undo all 6 screws (1) on the torque converter.
- Prepare special tool **0 494 478 (24 4 161)** (1) with the shaped element **0 494 965 (24 4 165)** (2) as shown.

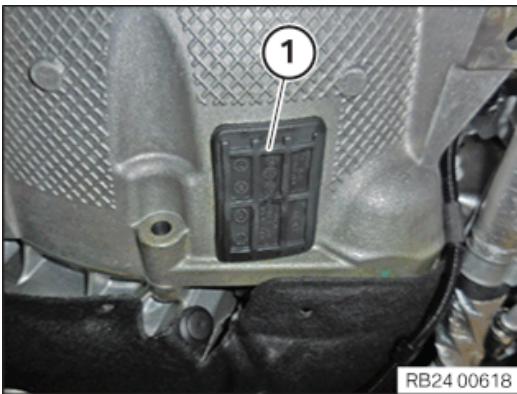
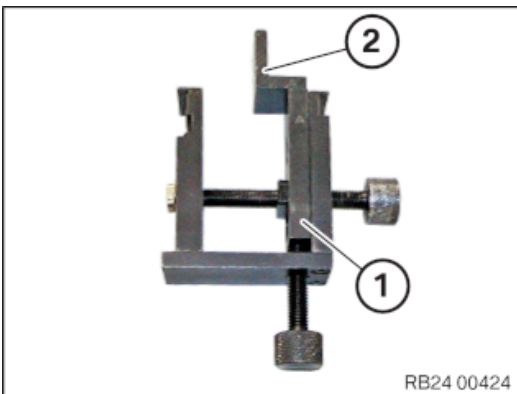

- Remove the sealing cap (1).

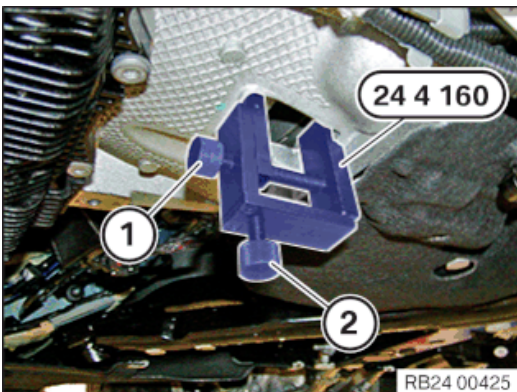

- Insert special tool **0 494 451 (24 4 160)** into the recess of the transmission housing and apply slight tension using the screw (1).
- Screw the bolt (2) in to the stop.
- Tighten down screw (1).

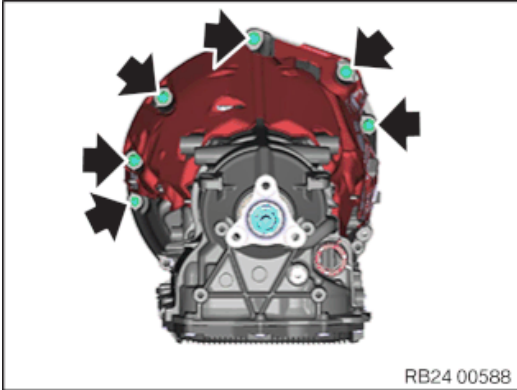
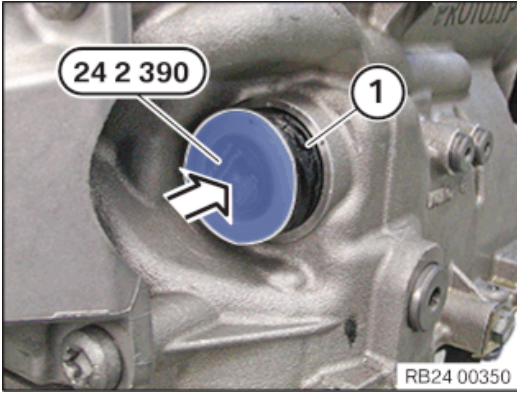
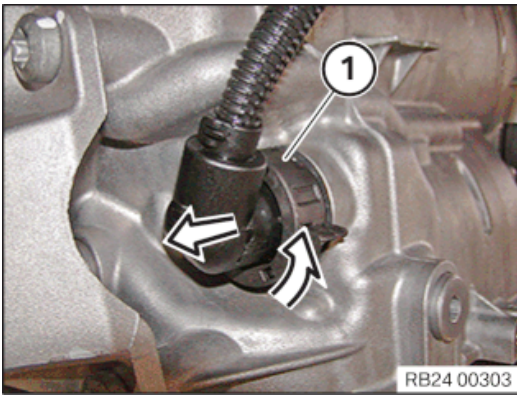

Notes on mechatronics are a fundamental requirement for these repair instructions and must be complied with at all times.  
For additional information see: 24 34 ... Notes on mechatronics (GA8HP50Z/GA8HP51Z/GA8HP75Z/GA8HP76Z/GA8HP95Z)

- Unlock connector (1) by turning and pull off.
- Do not touch pins.
- Loosen all cable clips.
- Insert the special tool **0 494 213 (24 2 390)** into the sealing sleeve (1).
- Support engine.
- Unscrew the remaining 6 transmission bolts (arrows) and remove the transmission.

## MAIN WORK

### 54 – Removing engine



Collect and dispose of emerging fluids. Observe country-specific waste disposal regulations.

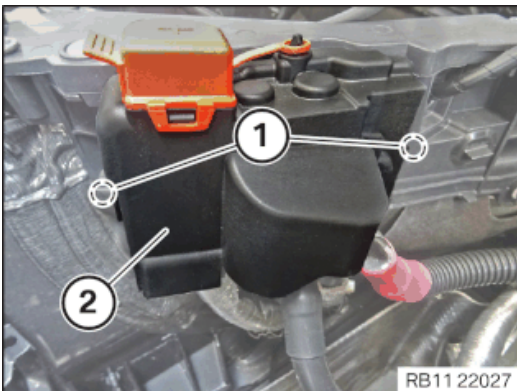

- Remove the cover (2) from the latch mechanisms (1).
- Remove the cover (2) in an upwards direction.

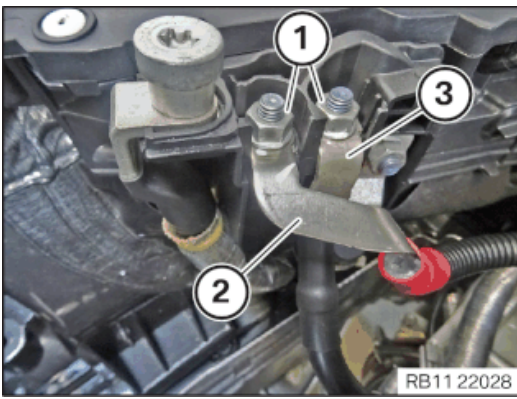

- Loosen nuts (1).
- Remove the positive battery cable (2) and set it aside.
- Remove the positive battery cable (3) and set it aside.

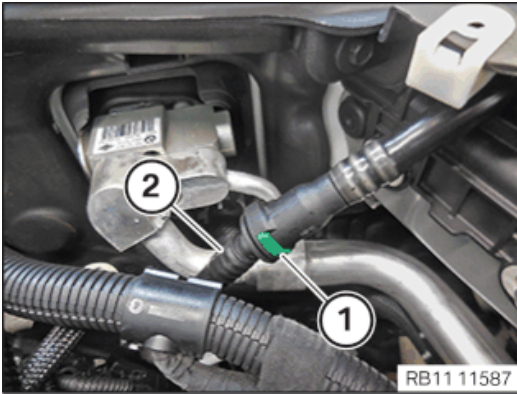

- Unlock the lock (1).
- Feed out the vacuum line (2) and set it aside.

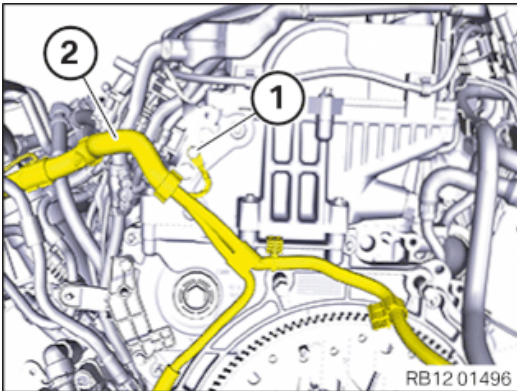

- Loosen screw (1).
- Guide out the wiring harness section (2) for the automatic transmission and set it aside.

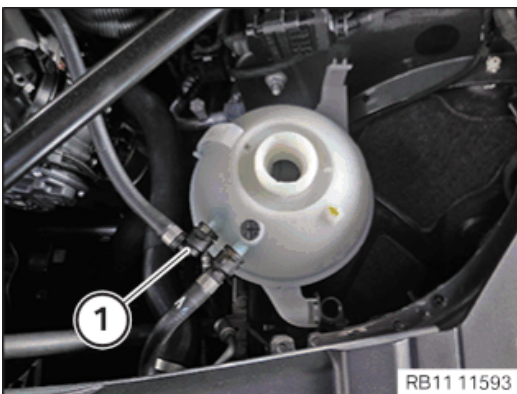

- Unlock and loosen coolant line (1).

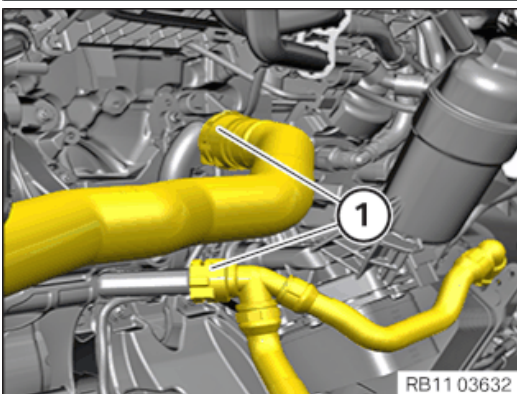

- Unlock and pull off the coolant hoses (1).

► **Disconnect the fuel lines in the engine compartment**



### Working on fuel system.

#### Risk of fire! Danger of explosion!

- When working on the fuel system, make sure that the workbay is sufficiently ventilated, e.g. using extraction unit.
- Tightly seal off open lines and connections; collect any escaping fuel directly at the point of exit.
- No fire, sparks, open flames or smoking.



### Contaminant or foreign body.

#### Contamination can result in malfunctions, operating failure or leaks.

- Adhere to the utmost cleanliness.
- Protect components from contamination e.g. by covering.
- Close off line connections with seal plugs.



Collect and dispose of emerging fluids. Observe country-specific waste disposal regulations.

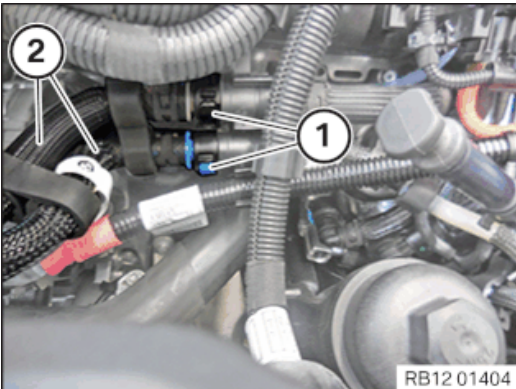

- Unlock and loosen the locks (1).
- Catch and dispose of escaping fuel.
- Guide out fuel lines (2) and set them aside.

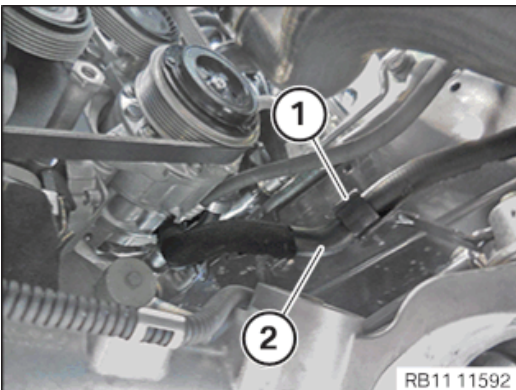

- Unlock and loosen holder (1).
- Feed out coolant line (2) and place to one side.

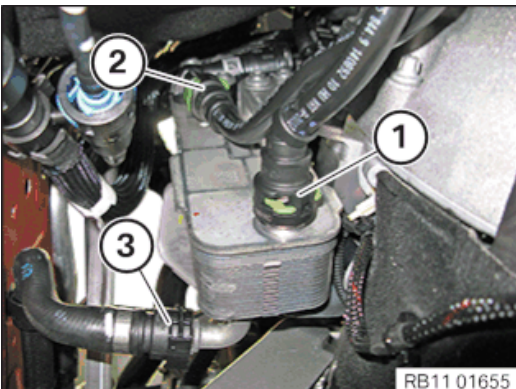

- Unlock and disconnect the oil return line (1) from the bottom.
- Unlock and disconnect the oil feed line (2) from the bottom.
- Catch and dispose of emerging oil.
- Catch and dispose of escaping coolant.
- Unlock coolant line (3) and pull off.

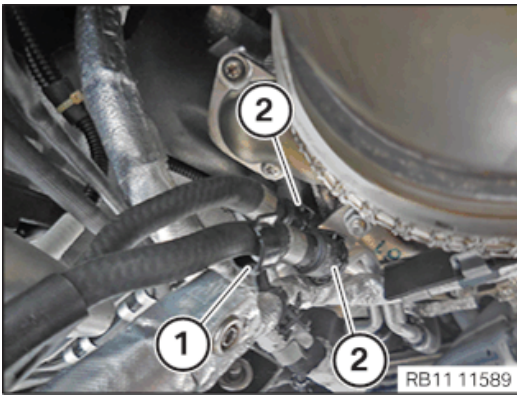

- Loosen the holder (1).
- Unlock and release coolant line (2).
- Catch and dispose of escaping coolant.

► **Disconnect the engine support arms from the left and right engine mounts**

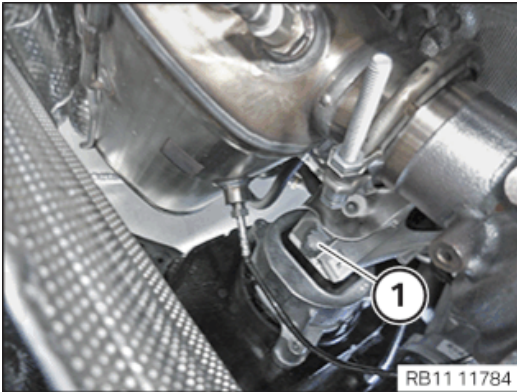

- Undo screw (1) on engine support arm on the right from the top.

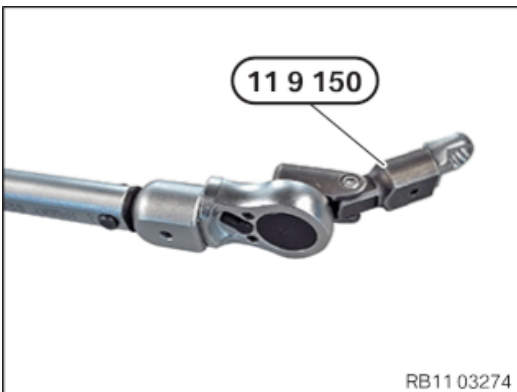

- Prepare special tool as shown.

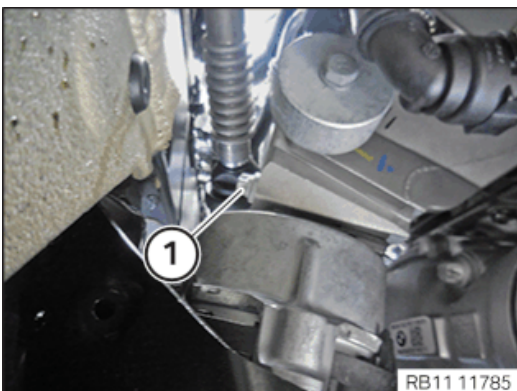

- Undo screw (1) on left engine support arm using special tool from the bottom.



- Prepare the workshop crane **2 220 718**.

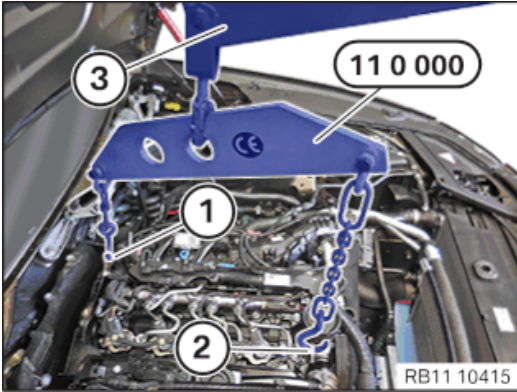

**i**

Conduct the following operation with the assistance of a second person.

- Attach special tool **0 490 561 (11 0 000)** to workshop crane.
- Attach the special tool **0 490 561 (11 0 000)** on engine mounting brackets (1) and (2) only.
- Pull the engine out with the workshop crane (3) and remove it.

## 55 – Install engine

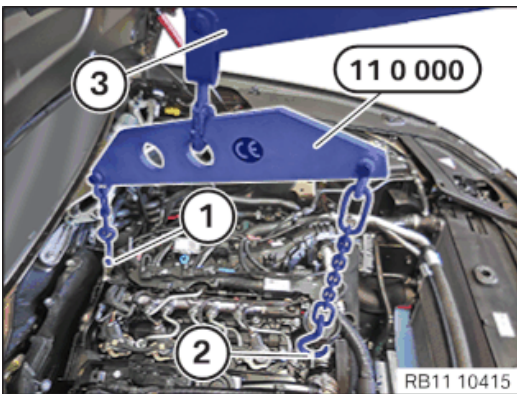

**i**

Conduct the following operation with the assistance of a second person.

- Attach the special tool **0 490 561 (11 0 000)** to the workshop crane (3).
- Attach the special tool **0 490 561 (11 0 000)** on engine mounting brackets (1) and (2) only.
- Guide in and install the engine with workshop crane (3) .
- Release the special tool **0 490 561 (11 0 000)** from the engine mounting brackets (1) and (2).
- Place the workshop crane (3) aside.

► **Install the engine support arms on the engine mounts on the left and right**

**i**

In order to prevent play, lower the engine completely before screwing the engine mount and engine mounting bracket.

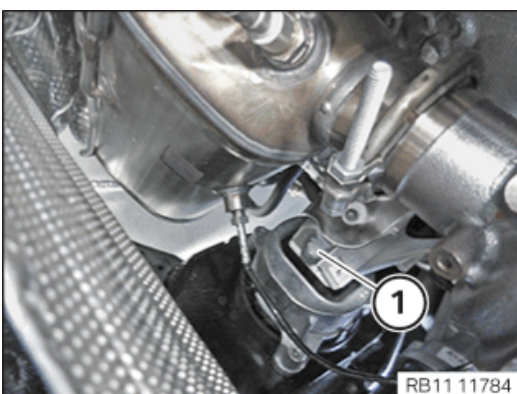

- Tighten screw (1) on engine support arm on the right from the top.

### Engine support bracket to engine mount

M12x1.5x40

Tightening  
torque

100 Nm

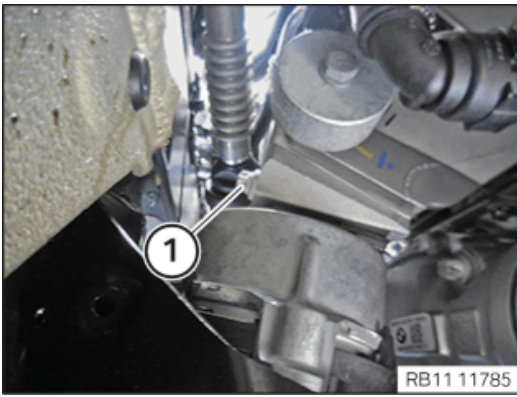

- Tighten screw (1) on left engine support arm using special tool from the bottom.

#### **Engine support bracket to engine mount**

M12x1.5x40

Tightening  
torque

100 Nm

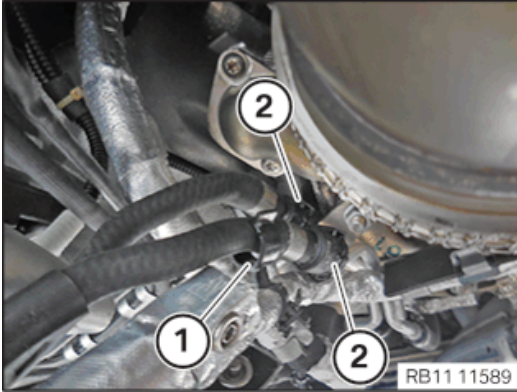

- Thread in and install coolant line (2).
- Make sure that you can hear the coolant lines (2) engage.
- Secure the holder (1).

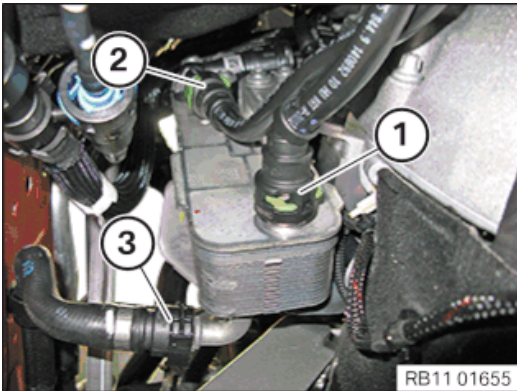

- Connect and lock coolant line (3).
- Make sure that the cooling line (3) engages audibly.
- Connect the oil return line (1) and lock.
- Connect the oil feed line (2) and lock.
- Make sure that you can hear the oil lines engage.

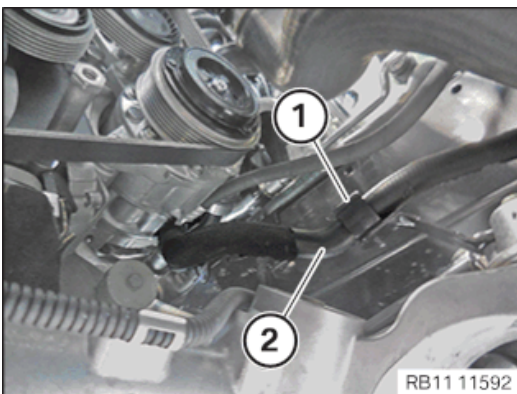

- Feed in and install coolant line (2).
- Lock holder (1).

#### **► Connecting fuel lines in engine compartment**

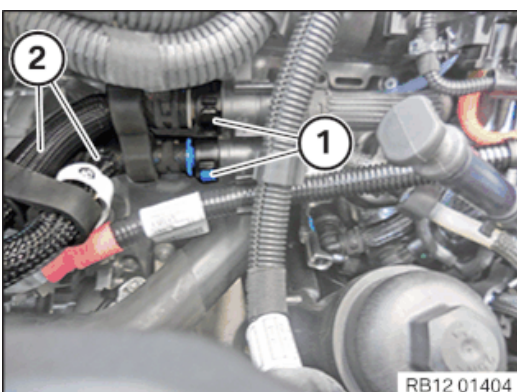

- Insert and connect fuel lines (2).
- Ensure that the locks (1) engage audibly.

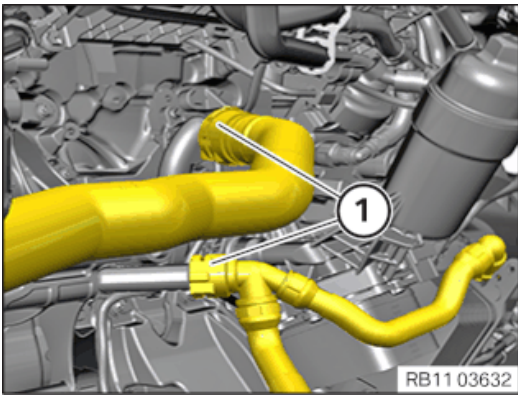

Make sure that the connections are locked correctly. The locks must engage audibly.

- Connect coolant hoses (1) and lock audibly.

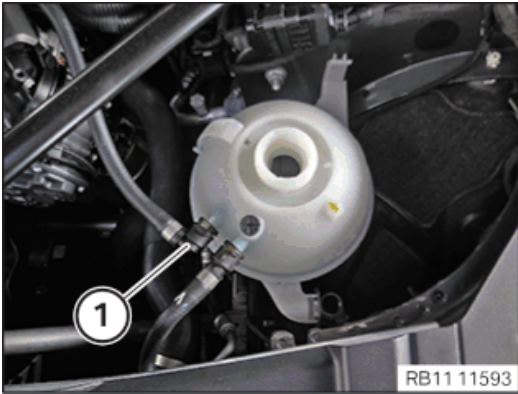

- Connect and lock coolant line (1).
- Make sure that the cooling line (1) engages audibly.

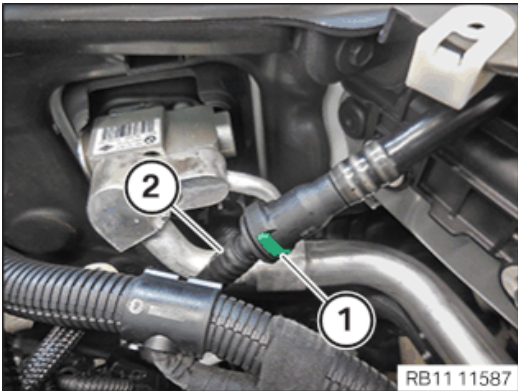

- Connect the vacuum line (2) and lock.
- Ensure that the lock (1) engages audibly.

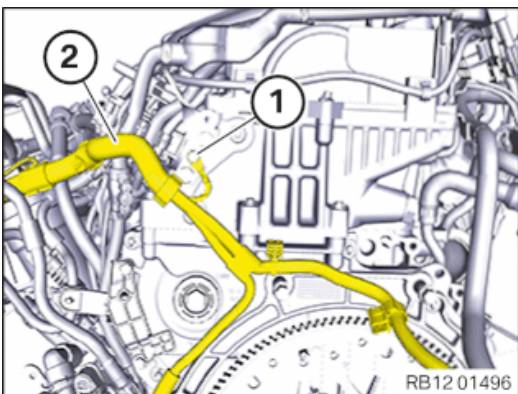

- Guide in the wiring harness section (2) for the automatic transmission and install.
- Tighten down screw (1).

#### Ground to cylinder head

M6	Tightening torque	8 Nm
----	-------------------	------

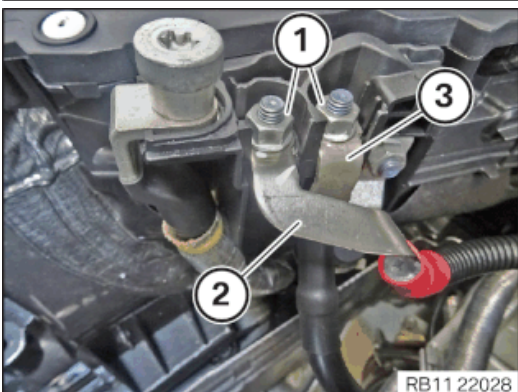

- Insert and position the positive battery cable (3).
- Insert and position the positive battery cable (2).
- Tighten nuts (1).

#### Positive battery cable

Positive pole screw	Tightening torque	15 Nm
---------------------	-------------------	-------

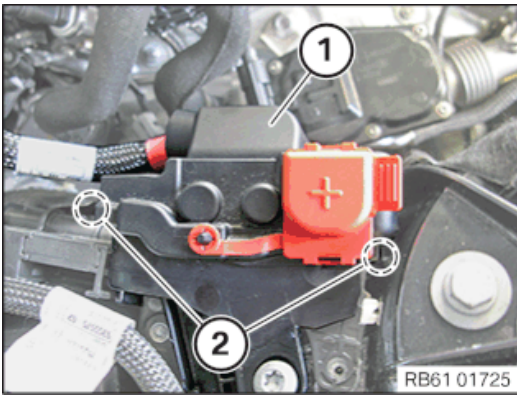

- Feed in the cover (1) downwards.
- Engage the cover (1) with the latch mechanisms (2).

## POSTPROCESSES

### 56 – Install automatic transmission (GA8HP51Z)



**Damage to the transmission.**

**Damage to the transmission by unapproved transmission oil.**

- Use only the approved transmission oil.
- Check the transmission oil level after completing the repair.



After completion of the work, program the control unit for the electronic transmission control (EGS).

#### ► Checking mounting orientation of torque converter

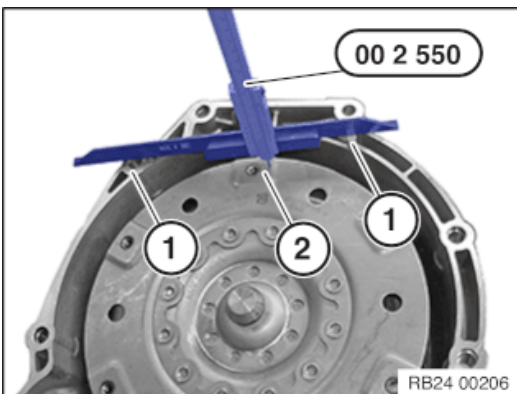

**Damage to the automatic transmission/impeller.**

**When disconnecting the engine and transmission, the torque converter can become loose! Failure to observe the correct installation positions of the torque converter may lead to damage to the impeller driver.**

- Make sure that the torque converter is in the correct installation position before installing the automatic transmission.
- Check the installation dimension between the contact surfaces (1) and the outer edge (2) of the torque converter threaded hole using special tool **0 490 189 (00 2 550)**.

See repair instructions

Remove and install/replace torque converter ( )

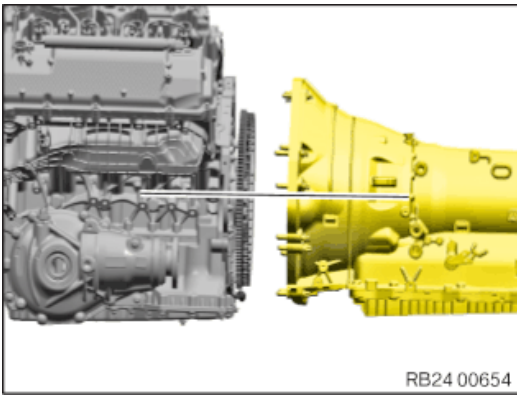

**Damage to flywheel and automatic transmission.**

**If the automatic transmission is not fitted horizontally while removing and installing it, then this can cause damage to the automatic transmission or the flywheel.**

- While removing and installing, align the automatic transmission fully horizontal to the engine.
- Check for a correct alignment before tightening the transmission bolts.

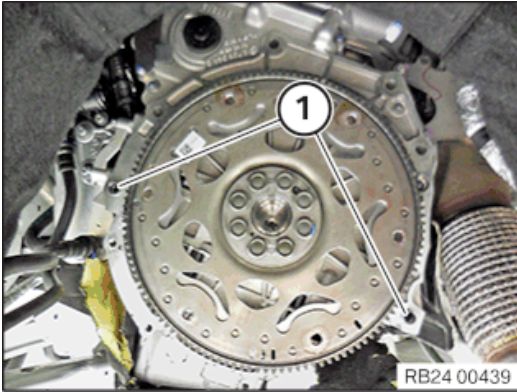

- Align the automatic transmission horizontal to the engine before installation.
- Check the fitting sleeves (1) for correct fit and damage and renew as needed.

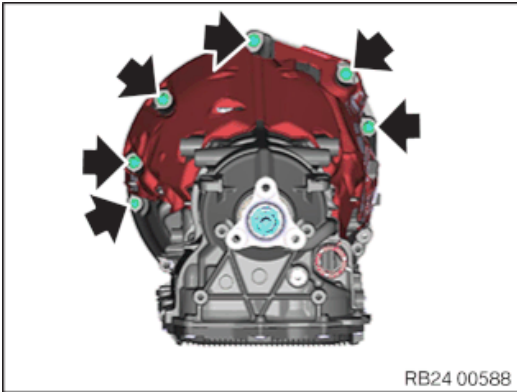

- Transmission flange-mount.
- Rotate torque converter until bore hole in torque converter is flush with bore hole in drive plate.
- Fit the transmission bolts (arrows) and apply hand-tight.

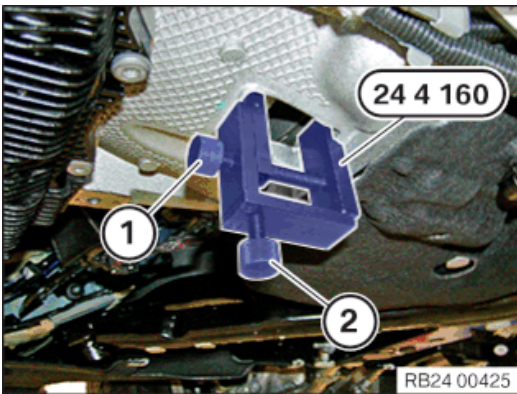

- Release screw (1) and screw (2).
- Remove special tool **0 494 451 (24 4 160)**.

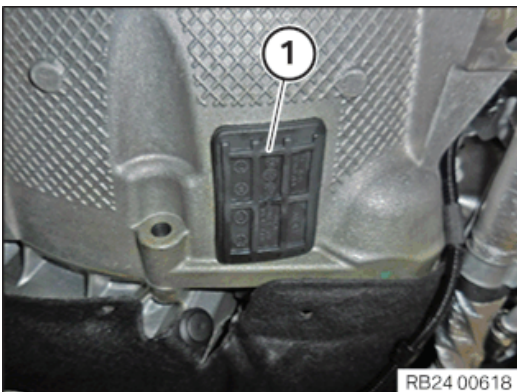

- Install the sealing cap (1).

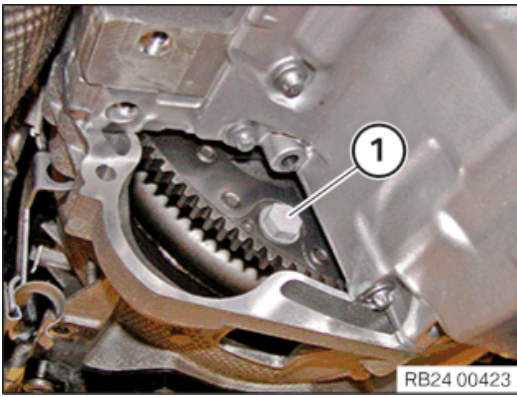

**Only G05 and G07**

In vehicles with active anti-roll bar (ARS) the fan cowl must be removed in order to spin the engine.

For additional information see: 17 11 035 Removing and installing/replacing the fan cowl including electric fan

- Renew screws.

**Parts:** Screws

- Crank the engine on the vibration damper in the direction of rotation using special tool **0 493 380 (11 6 480)** to tighten all six screws (1).
- Tighten all 6 screws (1) of the torque converter using special tool **0 491 667 (24 1 110)**.

**Torque converter to flywheel**

M10	Renew screws.	Tightening torque	56 Nm
-----	---------------	-------------------	-------

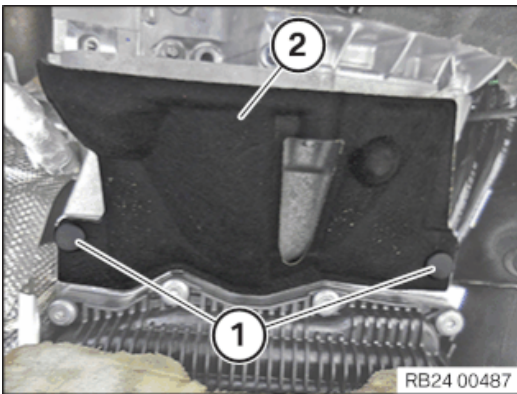

- Install acoustic cover (2).
- Install expanding rivet (1).

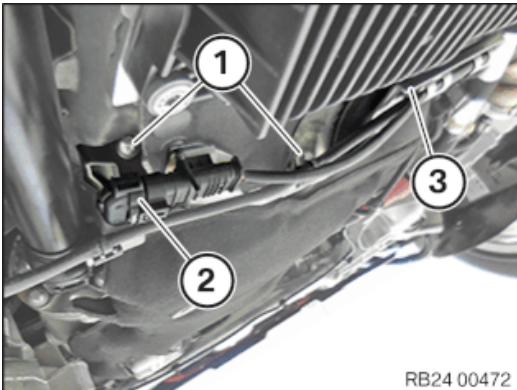

- Install holder (3).
- Connect connector (2).
- Insert screws (1) and tighten lightly.

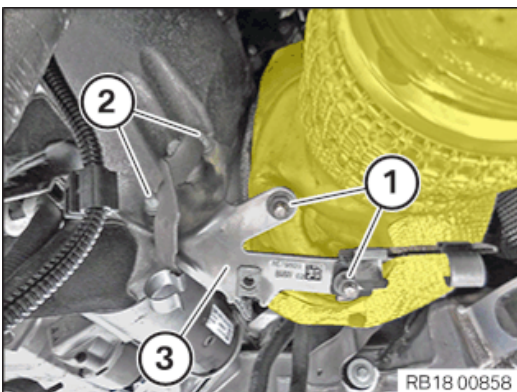

- Insert and install the holder (3).
- Tighten the screws (2) from the bracket (3).

**Bracket to transmission for diesel particulate filter holder bottom**

M8X20		Tightening torque	19 Nm
-------	--	-------------------	-------

- Tighten the nuts (1) on the holder (3).

**Lower holder to diesel particulate filter**

M8		Tightening torque	19 Nm
----	--	-------------------	-------

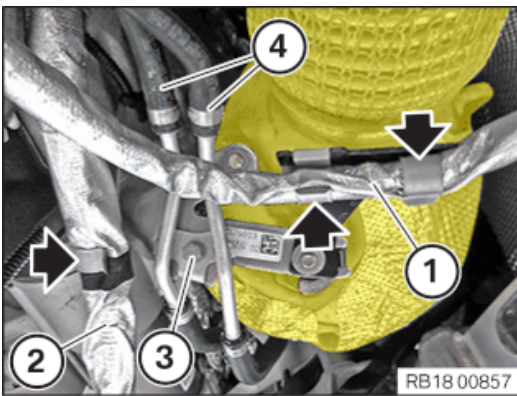

- Thread in and install coolant line (4).
- Tighten down screw (3).

#### Coolant line to crankcase/diesel particulate filter

M6x16

8 Nm

- Secure the positive battery cable (2) of the starter motor at the clamp (arrow).
- Fasten the metering line (1) on the clamps (arrows).

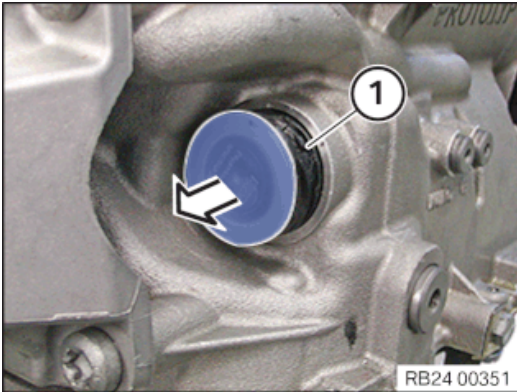

- Remove the special tool **0 494 213 (24 2 390)** from the sealing sleeve in direction of arrow.

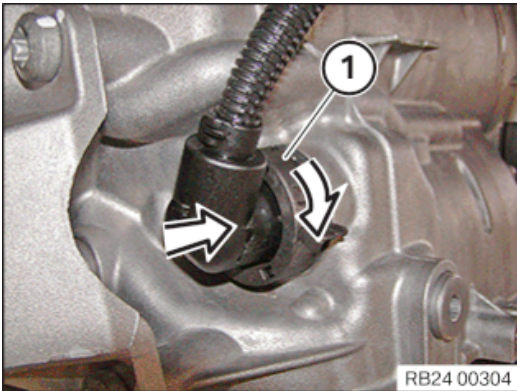

- Slide the connector (1) on and turn it to lock.



Notes on mechatronics are a fundamental requirement for these repair instructions and must be complied with at all times.

For additional information see: 24 34 ... Notes on mechatronics (GA8HP50Z/GA8HP51Z/GA8HP75Z/GA8HP76Z/GA8HP95Z)

- Tighten the transmission bolts in sequence (1) to (9).

#### Transmission to engine

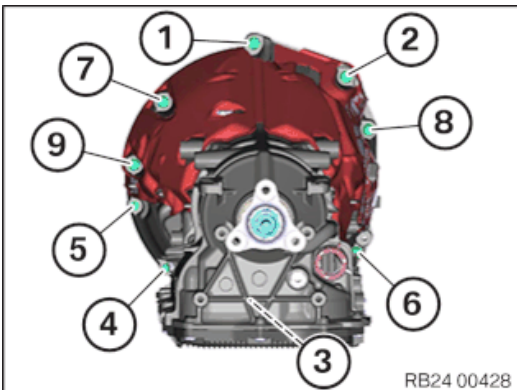

M8

Tightening torque

19 Nm

M12

Tightening torque

66 Nm

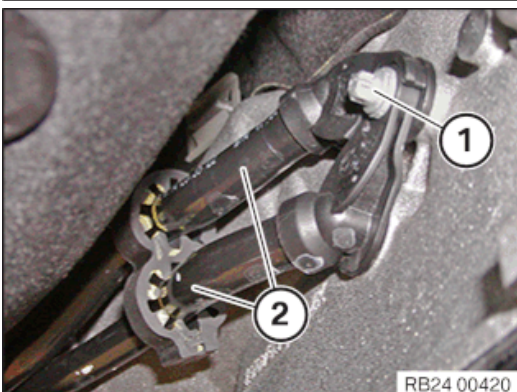

- Renew sealing rings.

**Parts:** Sealing ring

- Install hydraulic lines (2) on transmission.
- Position and tighten the screw (1).

#### Transmission oil line to transmission

M6x25

Renew the sealing ring.

Tightening torque

8 Nm

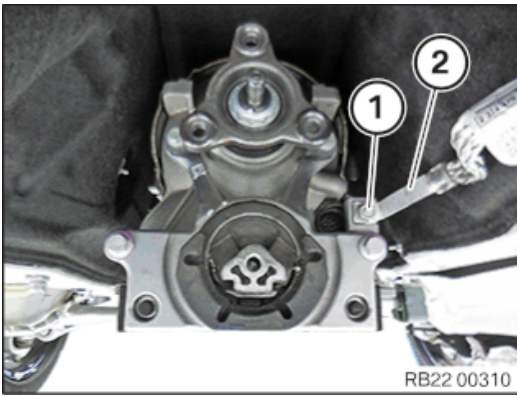

- Install the ground strap (2).
- Tighten down screw (1).

**Ground strap to transmission or body**

M8	Tightening torque	19 Nm
----	-------------------	-------

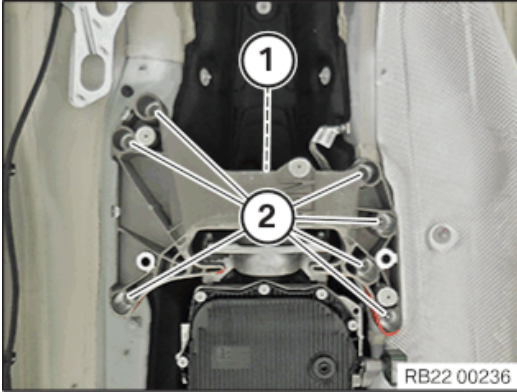

- Install transmission cross-member.
  - Renew the screw (1).
- Parts:** Screw
- Tighten down screw (1).

**Transmission cross member to rubber mounts**

M12	Tightening torque	100 Nm
-----	-------------------	--------

- Renew screws(2).
- Parts:** Screws
- Tighten the screws (2).

**Transmission cross member to body**

M8	Tightening torque	19 Nm
----	-------------------	-------

- Remove the transmission jack.

**57 – Installing starter motor**

► **Installing the starter motor on vehicles with all-wheel drive**

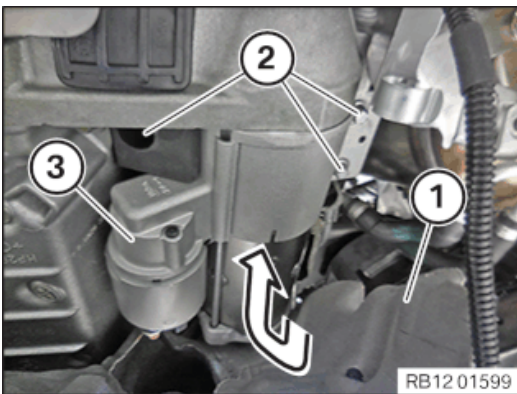

- Make sure that the acoustic cover (1) is not damaged.
- Carefully press the acoustic cover (1) to one side.
- Feed in and install the starter motor (3) in the direction of the arrow.
- Tighten the screws (2).

**Starter motor to crankcase**

M8x60	Tightening torque	19 Nm
-------	-------------------	-------

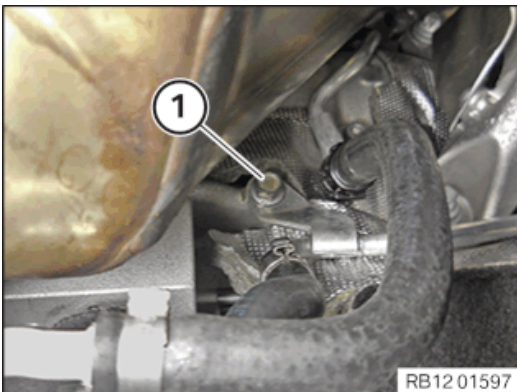

- Mount the coolant lines.
- Tighten down screw (1).

**Coolant line to crankcase/diesel particulate filter**

M6x16		8 Nm
-------	--	------

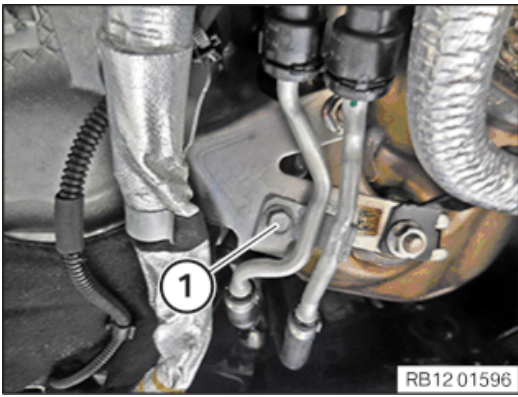

- Mount the coolant lines.
- Tighten down screw (1).

#### Coolant line to crankcase/diesel particulate filter

M6x16

8 Nm

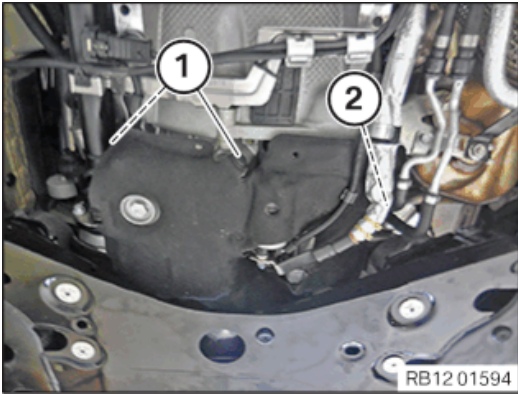

- Position acoustic cover.
- Mount the expanding rivets (1) in the rear on the acoustic cover.
- Renew the clip (2).

**Parts:** clip

- Mount the clip (2).

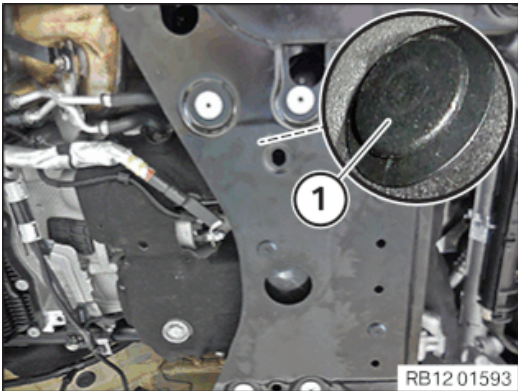

- Mount the expanding rivets (1) in the centre of the acoustic cover.

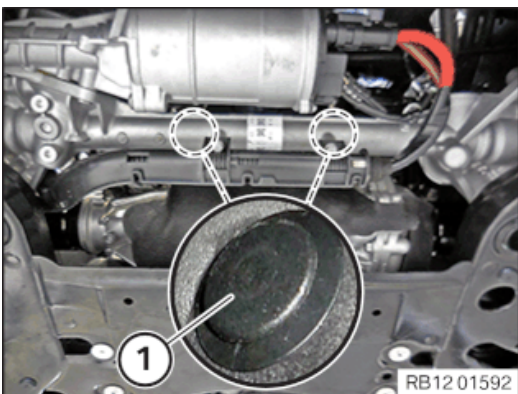

- Mount the expanding rivets (1) in the front on the acoustic cover.

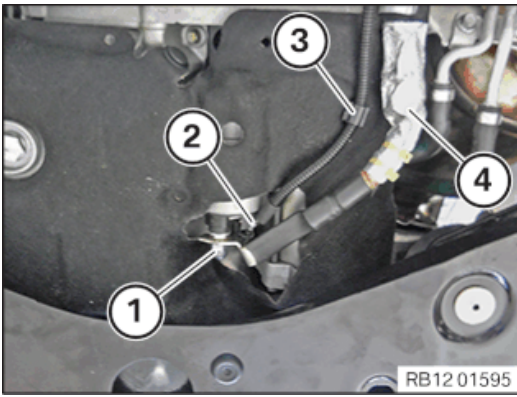

- **Version A:**
- Connect the cable (terminal 50) to the starter motor and secure it with the nut (2).
- Tighten nut (2).

#### Terminal 50 to starter motor

M6	Tightening torque	7,5 Nm
----	-------------------	--------

- Connect the positive battery cable to the starter motor and secure it with the nut (1).
- Tighten nut (1).

#### Battery positive lead to starter

M8	Tightening torque	13,5 Nm
----	-------------------	---------

- Secure the cable (terminal 50) at the clamp (3).
- Secure positive battery cable at the clamp (4).

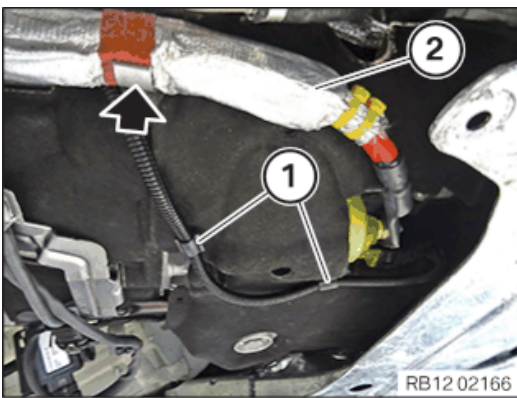

- **Version B:**
- Secure and position positive battery cable (2) on the holder (arrow).
- Secure clamps (1).

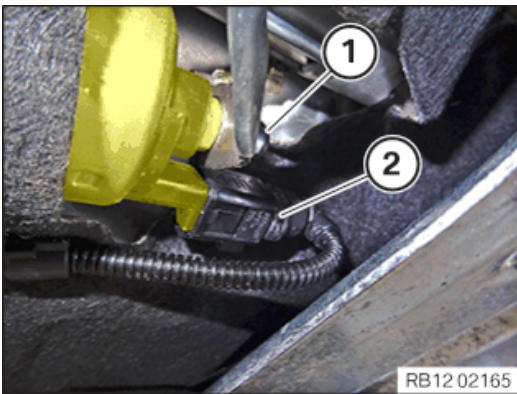

- Connect connectors (2) and lock.
- The connector (2) must engage audibly.
- Tighten the nut (1) hand-tight.

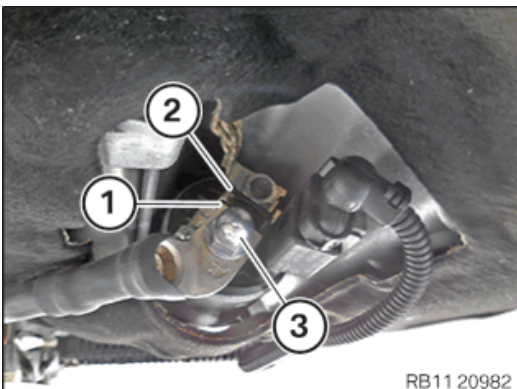

- Attach the positive battery cable (1) **correctly** to anti-twist lock (2).
- Tighten nut (3).

#### Terminal 50 to starter motor

M6	Tightening torque	7,5 Nm
----	-------------------	--------



#### Improper routing of the positive battery cable.

#### Risk of short circuits!

- Route the positive battery cable without abrasions and do not trap.

► **Installing the starter motor for vehicles with rear-wheel drive**

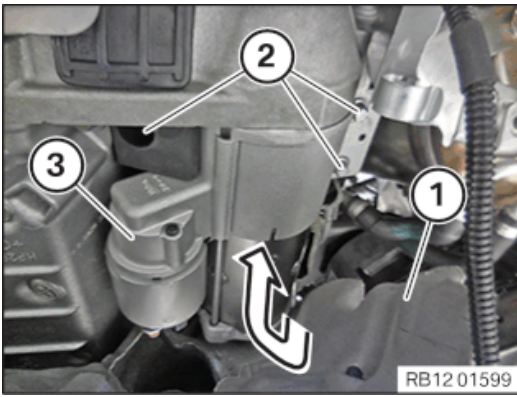

- Make sure that the acoustic cover (1) is not damaged.
- Carefully press the acoustic cover (1) to one side.
- Feed in and install the starter motor (3) in the direction of the arrow.
- Tighten the screws (2).

#### **Starter motor to crankcase**

M8x60

Tightening  
torque

19 Nm

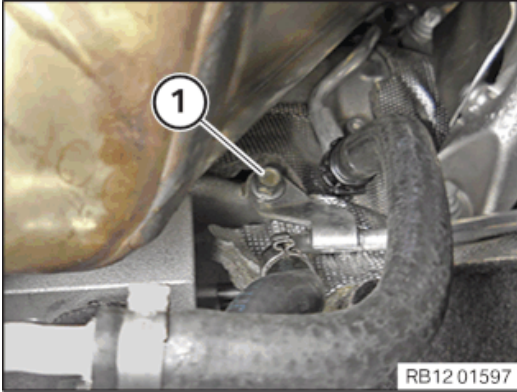

- Mount the coolant lines.
- Tighten down screw (1).

#### **Coolant line to crankcase/diesel particulate filter**

M6x16

8 Nm

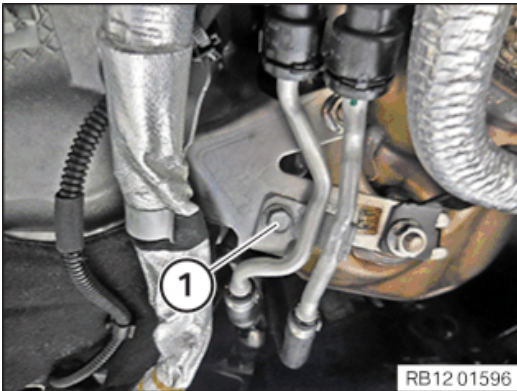

- Mount the coolant lines.
- Tighten down screw (1).

#### **Coolant line to crankcase/diesel particulate filter**

M6x16

8 Nm

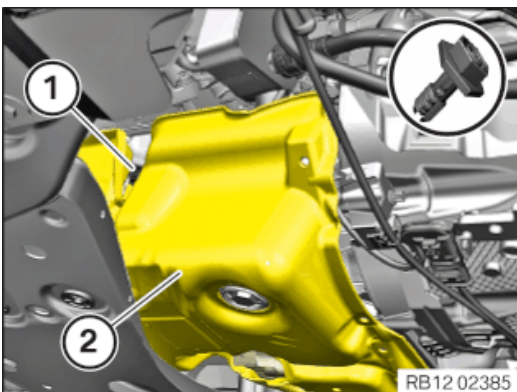

- Position the acoustic cover (2) of the oil sump.
- Secure expanding rivet (1).

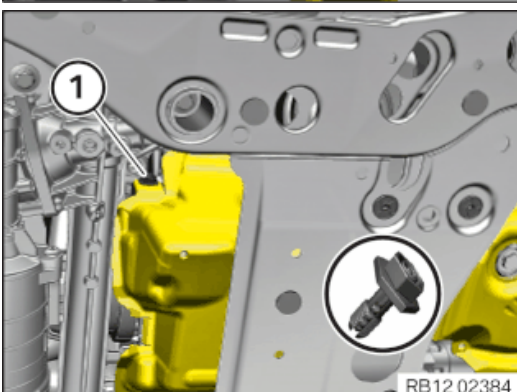

- Secure expanding rivet (1).

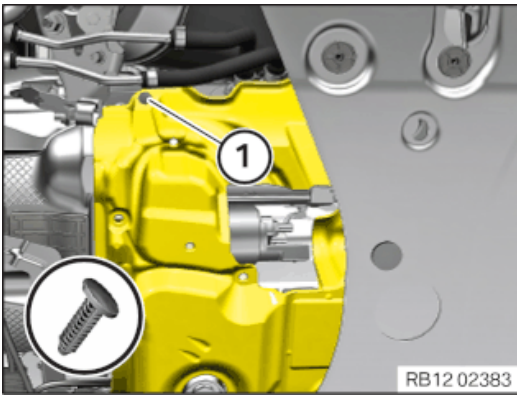

- Renew the fir tree clip (1).
- **Parts:** Fir tree clip
- Secure the fir tree clip (1).

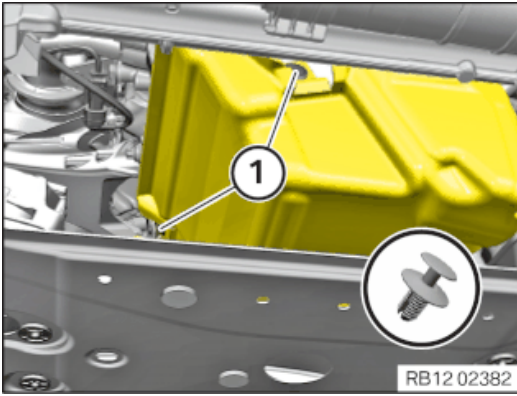

- Secure expanding rivet (1).

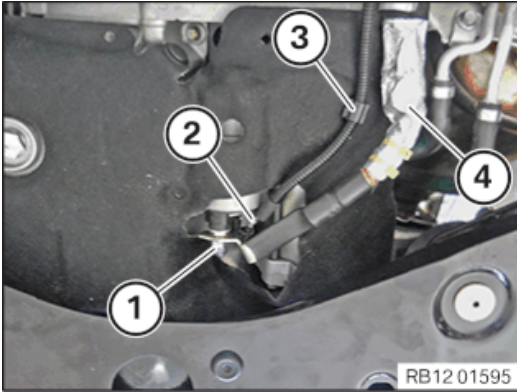

- **Version A:**
- Connect the cable (terminal 50) to the starter motor and secure it with the nut (2).
- Tighten nut (2).

**Terminal 50 to starter motor**

M6	Tightening torque	7,5 Nm
----	-------------------	--------

- Connect the positive battery cable to the starter motor and secure it with the nut (1).
- Tighten nut (1).

**Battery positive lead to starter**

M8	Tightening torque	13,5 Nm
----	-------------------	---------

- Secure the cable (terminal 50) at the clamp (3).
- Secure positive battery cable at the clamp (4).

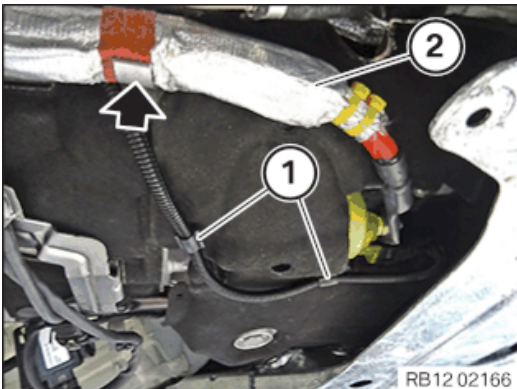

- **Version B:**
- Secure and position positive battery cable (2) on the holder (arrow).
- Secure clamps (1).

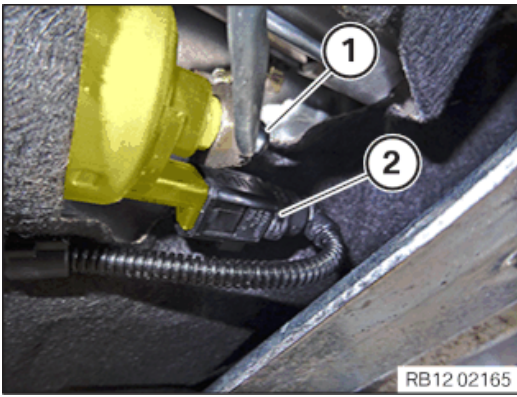

- Connect connectors (2) and lock.  
The connector (2) must engage audibly.
- Tighten the nut (1) hand-tight.

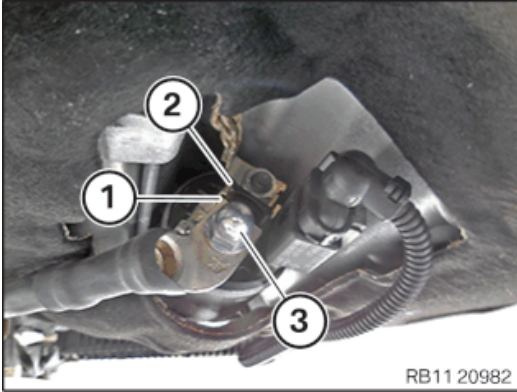

**Improper routing of the positive battery cable.**

**Risk of short circuits!**

- Route the positive battery cable without abrasions and do not trap.

- Attach the positive battery cable (1) **correctly** to anti-twist lock (2).
- Tighten nut (3).

#### Terminal 50 to starter motor

M6	Tightening torque	7,5 Nm
----	-------------------	--------

#### 58 – Install the retaining plates

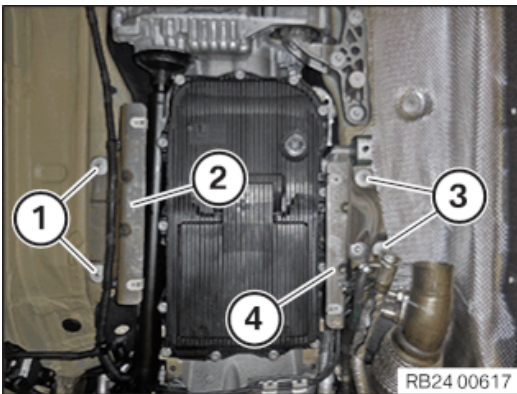

- Install the retaining plates (2) and (4).
- Renew the nuts (1) and (3).

**Parts:** Nuts

- Tighten nuts (1) and (3).

#### Retaining plates for vehicle underbody cover

Sheet metal nut/plastic nut	Renew nuts.	Tightening torque	3 Nm
-----------------------------	-------------	-------------------	------

#### 59 – Securing propeller shaft (partially removed)

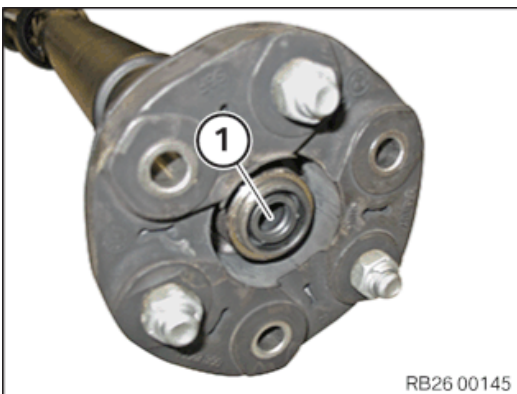

- Check centring (1) for damage; renew if necessary.

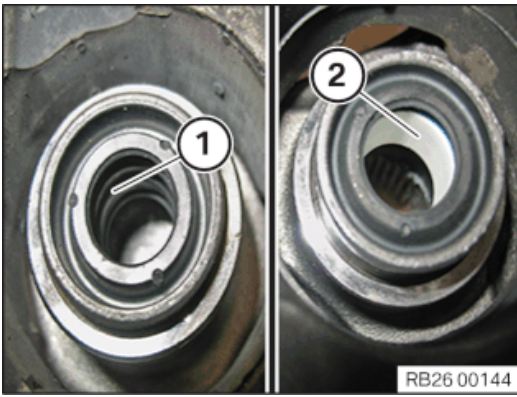

- Apply a thin coat of grease to the soft centring (1), if necessary.  
Do not grease the hard centring (2).

#### Expendable materials

Lubricating grease Olistamoly 2 LN 100 g,  
584 LO Tube

83 19 0 447 919

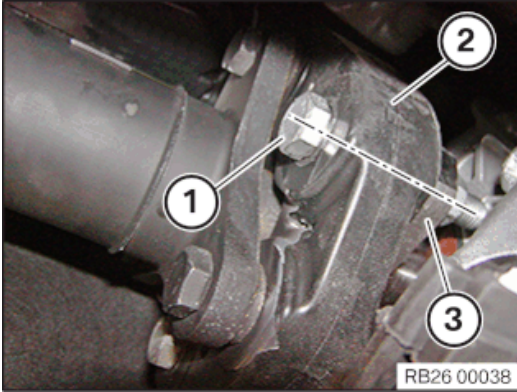

- Renew screws and the self-locking nuts.  
**Parts:** Screws, self-locking nuts
- Assemble the screw connections (1) of the flexible disc (2) and the three-hole flange (3) according to the self-affixed identification.

This should prevent a humming noise from the drive train during driving.

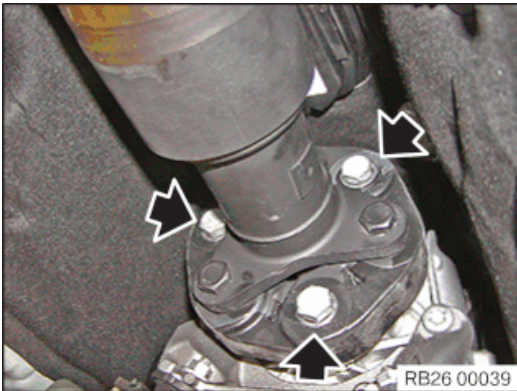

- Hand-tighten the screws and nuts (arrows), but do not tighten fully.

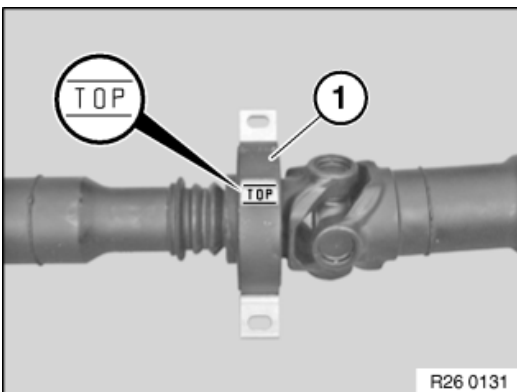

- Install the centre mount (1) with the designation **TOP** at the top in the transmission tunnel.

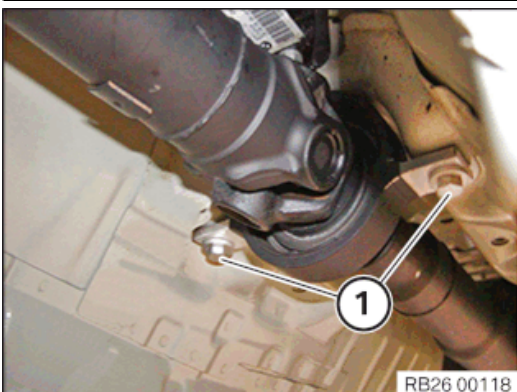

- Position centre mount.
- Hand-tighten the bolts (1), but do not tighten fully.

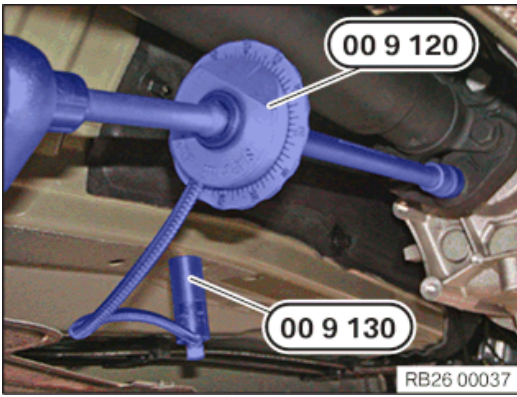

- Renew screws.

**Parts:** Screws

- Provide counter support for the bolts of the flexible disc on the nut and tighten with the bolts.

**Front flexible disc to propeller shaft**

M12	Renew screws. Comply with jointing torque and angle of rotation. Tightening via screw.	Jointing torque	55 Nm
		Angle of rotation	90 °

- Secure the special tool **0 490 504 (00 9 120)** with the special tool on the vehicle underbody and continue to screw it in according to the angle of rotation.

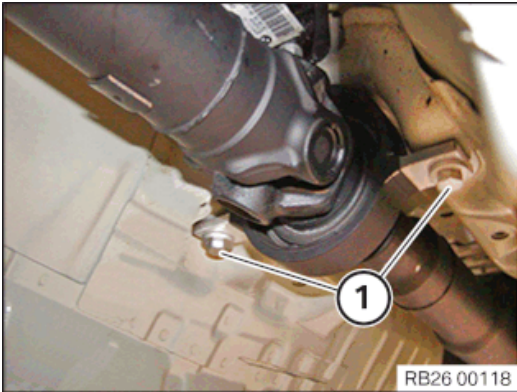

- Tighten the screws (1).

**Centre mount to body**

M8		Tightening torque	19 Nm
----	--	-------------------	-------

**60 – Installing the heat shields**

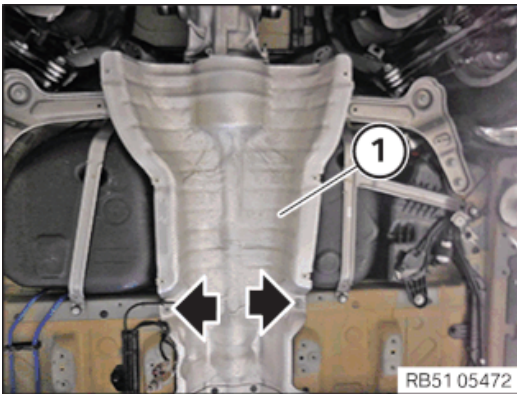

- Install heat shield (1).
- Tighten the nuts and bolts (arrows).

**Heat shield to undercarriage**

Screws and nuts		Tightening torque	3 Nm
-----------------	--	-------------------	------

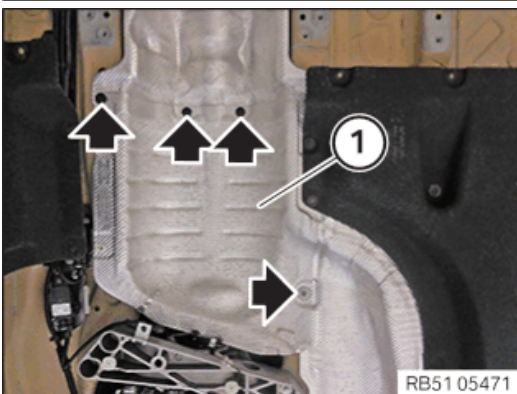

- Install heat shield (1).
- Tighten the nuts and bolts (arrows).

**Heat shield to undercarriage**

Screws and nuts		Tightening torque	3 Nm
-----------------	--	-------------------	------

**61 – Install the holder for the DDE control unit**

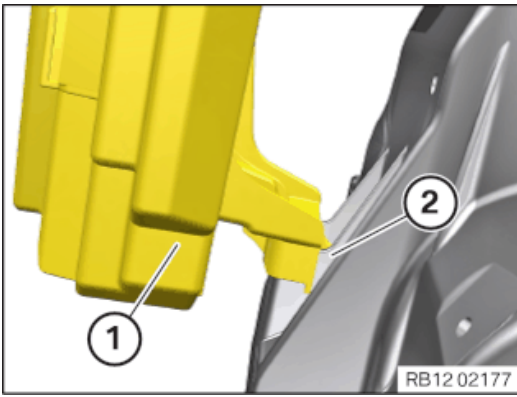

- Ensure that the bottom control unit holder (1) is inserted correctly in the fixture (2).

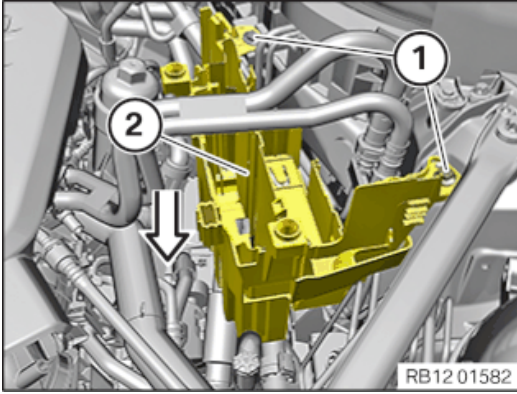

- Insert the holder (2) for the DDE control unit downwards in the direction of arrow and install it.
- Tighten the screws (1).

**Control unit holder on spring strut dome**

Hexagon screw	Tightening torque	8 Nm
---------------	-------------------	------

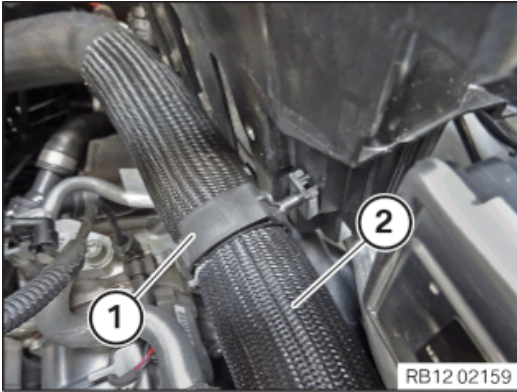

- Feed in and install coolant line (2).
- Lock holder (1).  
The holder (1) must engage audibly.

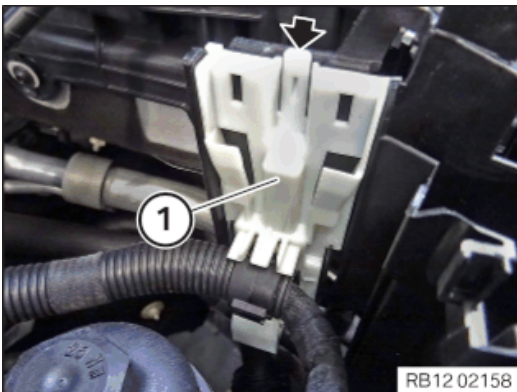

- Feed in and install the cable clip (1).  
Lock (arrow) must audibly engage.

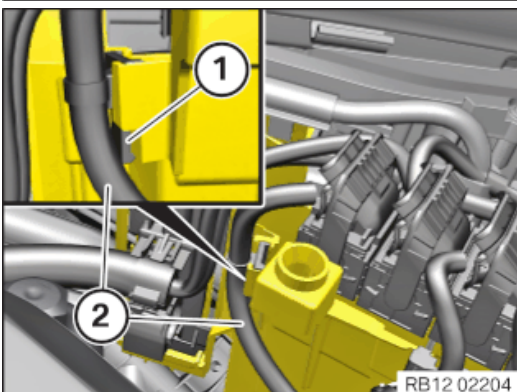

- Guide in the wiring harness section (2) and install.
- Connect and lock the cable clip (1).

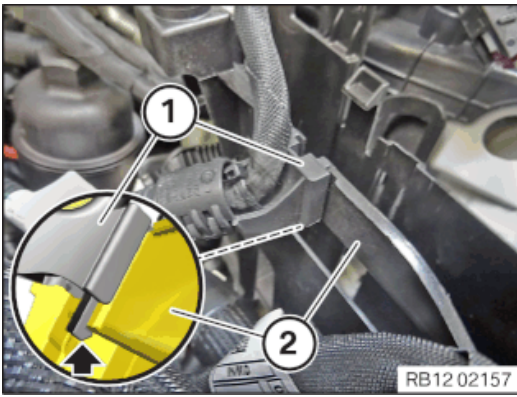

- Connect the cable clip (1) with the control unit holder (2) and lock it.  
Lock (arrow) must audibly engage.

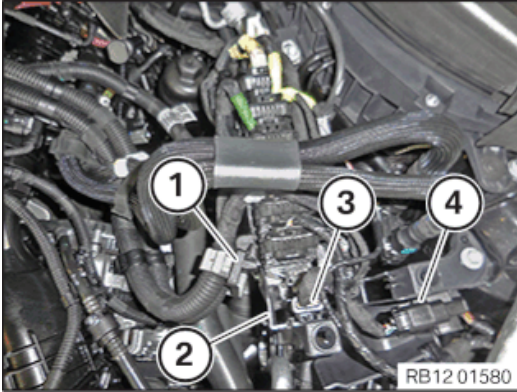

- Connect the connector (4) to the holder (2) for the DDE control unit and lock it.  
The connector (4) must lock audibly.
- Connect connectors (4) and lock.  
The connector (4) must lock audibly.
- Connect the connector (3) to the holder (2) for the DDE control unit and lock it.  
The connector (3) must lock audibly.
- Connect connectors (3) and lock.  
The connector (3) must lock audibly.
- Connect the cable clip (1) to the holder (2) for the DDE control unit and lock it.  
The cable clip (1) must lock audibly.

## 62 – Installing the integrated supply module (PDM)

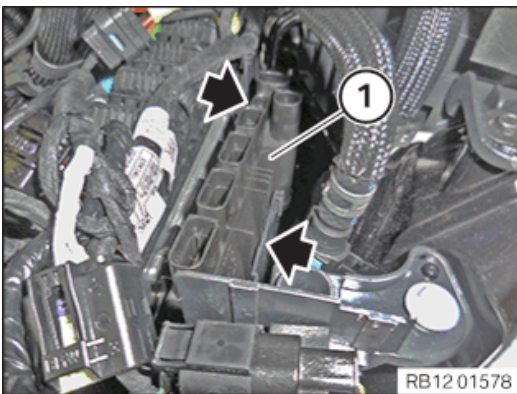

- Insert and install the integrated supply module (PDM) (1).  
The locks (arrows) must engage audibly.

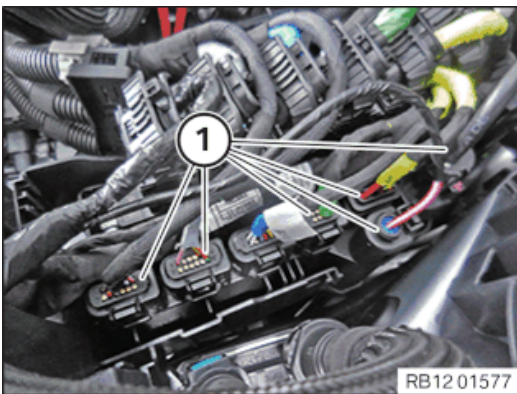

- Connect connectors (1) and lock.  
The connectors must engage audibly.

## 63 – Install DDE control unit



If the DDE control unit or an injector has been replaced, it will also be necessary to carry out injection quantity compensation. The adjustment value (7-position letter/number code) is engraved on each injector.



Follow instructions for removing and installing control units.  
For additional information see: 12 00 ... Notes on removal and installation of control units



Control unit must be programmed after it is replaced.  
For additional information see: 61 00 ... Programming/encoding control unit(s)



Disconnecting control units may cause fault code entries and functional limitations. Fault code entries must be read out and deleted if necessary.

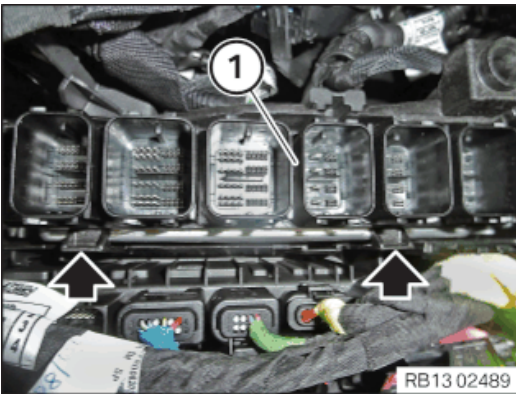

- Install DDE control unit(1).  
The latch mechanisms (arrows) must engage audibly.

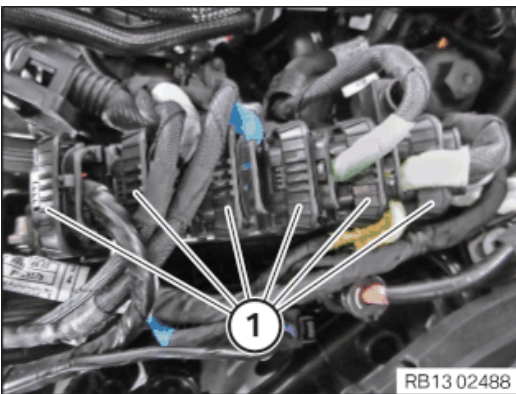

- Connect connectors (1) and lock.  
The connectors (1) must engage audibly.

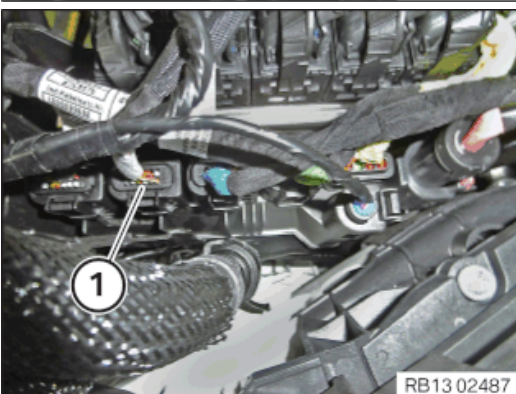

- Connect connectors (1) and lock.  
The connector (1) must engage audibly.

## 64 – Installing the cover of the DDE control unit

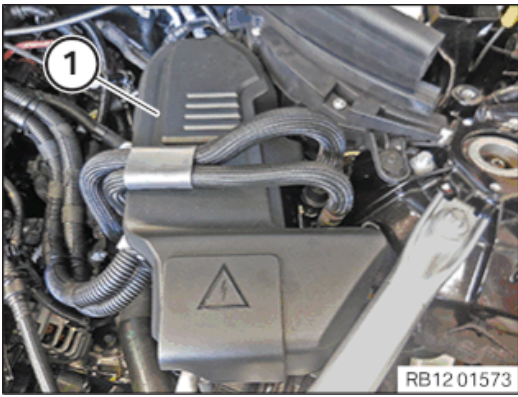

- Guide the cover (1) of the DDE control unit into the rubber mounts and install.

## 65 – Installing the diesel particulate filter



**Heavy component.**

**Heavy components can lead to injury or damage.**

- Remove and install heavy components with the aid of another person/other persons.

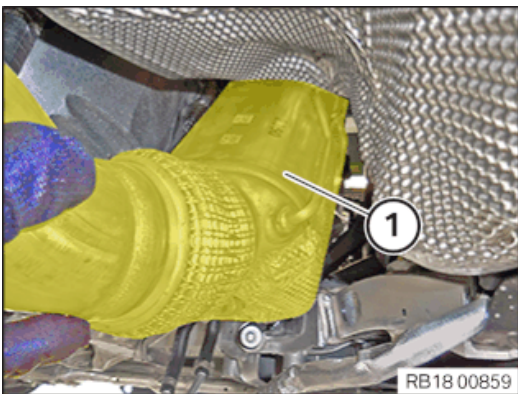

- Insert and install the diesel particulate filter (1).

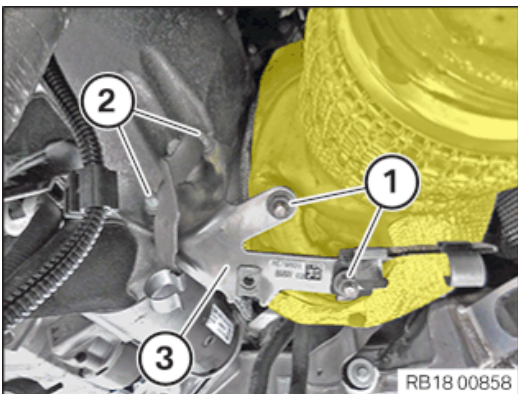

- Insert and install the holder (3).
- **Hand-tighten** the bolts (2).
- Apply the nuts (1) **hand-tight**.

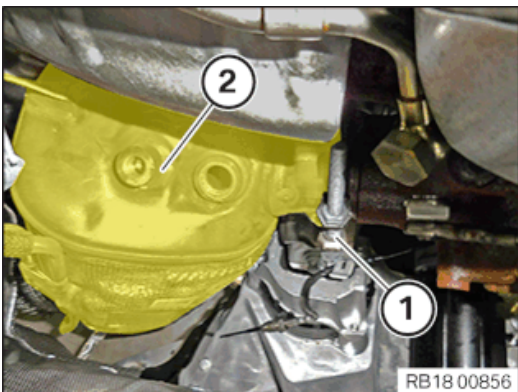

- Renew the V-clip (1).

**Parts:** V-band clamp

- Feed in and install V-band clamp (1).

**Note** Make sure that the seal between the diesel particulate filter and the exhaust turbocharger is installed correctly.

- Position the diesel particulate filter (2) on the exhaust turbocharger .
- Position V-clip (1).
- Apply the V-clip (1) **hand-tight**.

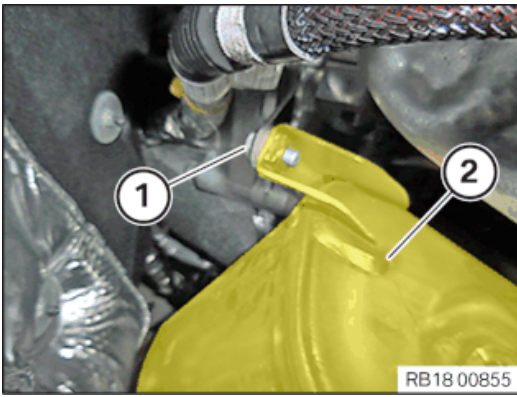

- Feed in screw (1) on the holder of the diesel particulate filter (2) and tighten **hand-tight**.

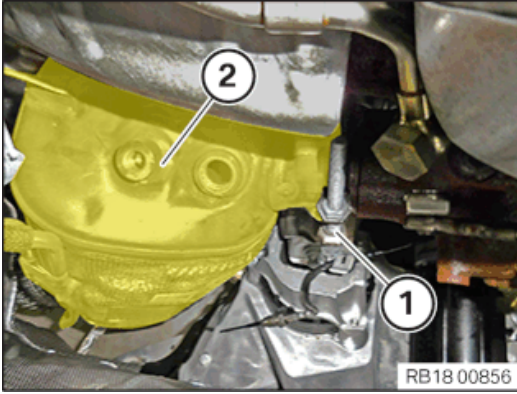

- Tighten the V-clip (1) of the diesel particulate filter (2).

#### **Diesel particulate filter V-clip to exhaust turbocharger**

V-band clamp	Renew V-band clamp.	Tightening torque	15 Nm
--------------	---------------------	-------------------	-------

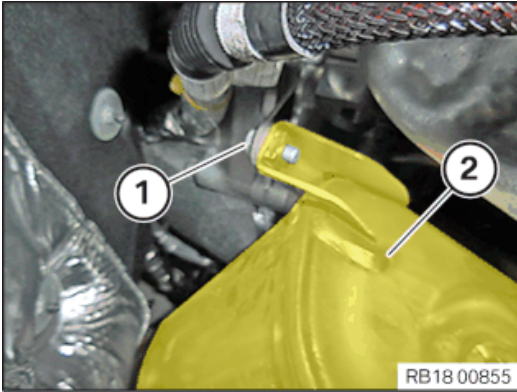

- Tighten the bolt (1) on the bracket of the diesel particulate filter (2).

#### **Bracket to diesel particulate filter top**

M8		Tightening torque	19 Nm
----	--	-------------------	-------

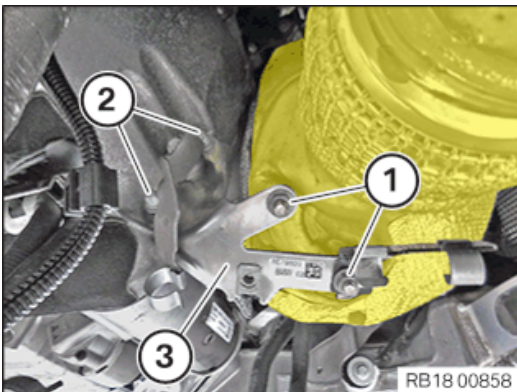

- Tighten the screws (2) on the holder (3).

#### **Bracket to transmission for diesel particulate filter holder bottom**

M8X20		Tightening torque	19 Nm
-------	--	-------------------	-------

- Tighten the nuts (1) on the holder (3).

#### **Lower holder to diesel particulate filter**

M8		Tightening torque	19 Nm
----	--	-------------------	-------

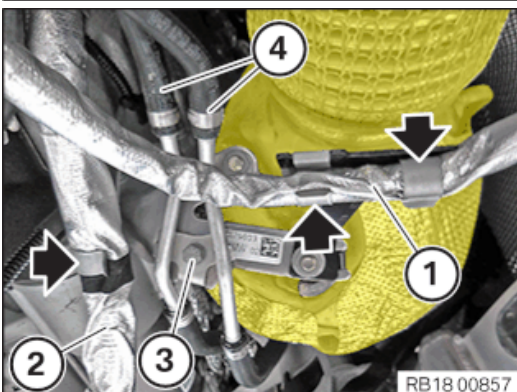

- Thread in and install coolant line (4).

- Tighten down screw (3).

#### **Coolant lines for SCR metering module**

M6X16		Tightening torque	8 Nm
-------	--	-------------------	------

- Secure the positive battery cable (2) of the starter motor at the clamp (arrow).

- Fasten the metering line (1) on the clamps (arrows).



### Component with heavy weight.

#### Danger of injury!

- Note component's centre of gravity.
- Support component using a jack.
- Secure component against falling off the jack.



### Heavy component.

#### Heavy components can lead to injury or damage.

- Remove and install heavy components with the aid of another person/other persons.



### Grinding dust when grinding components.

#### Hazardous to health!

- Directly draw off the grinding dust.
- Ensure adequate ventilation.
- Conduct all work in appropriate personal protective equipment only.



Mount the exhaust system in voltage-free state, maintaining the tightening sequence from the rear silencer towards the exhaust manifold.

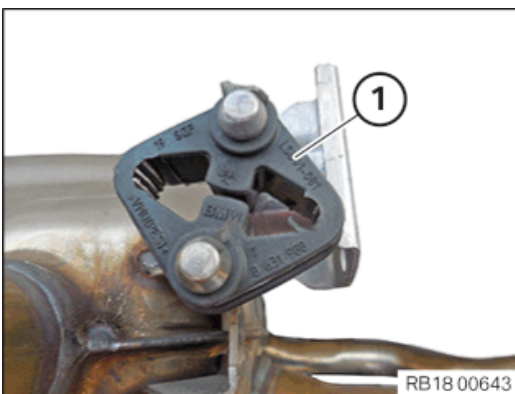

Schematic diagram is for example purposes. Some parts may differ in certain details.

- Check all the rubber mounts (1) of the exhaust system for damage.
- Replaced damaged rubber mounts.

**Parts:** Rubber mount

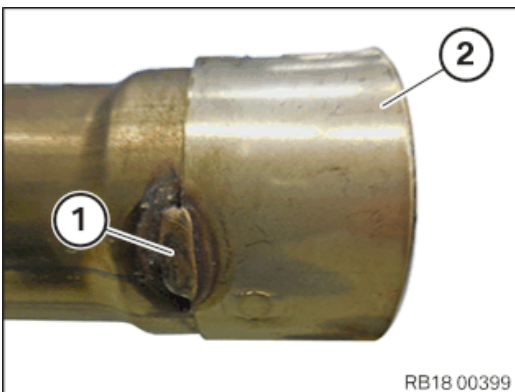

### Swarf resulting from sawing or grinding components.

#### Danger of injury!



- Conduct all work in appropriate personal protective equipment only.



- Wear safety goggles and protective gloves.

- Open the weld seam (1) with a conventional tool.
- Remove the current clamp (2).

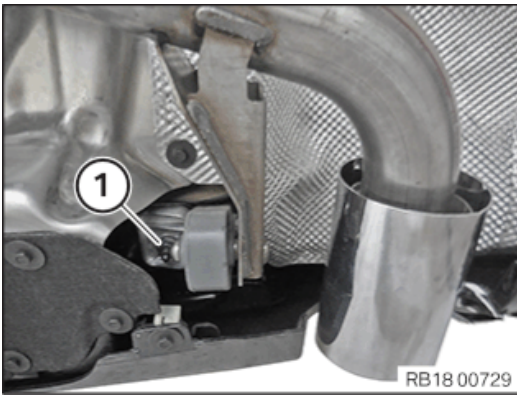

- Tighten nut (1).

#### Rear silencer to bumper support

M8	Tightening torque	19 Nm
----	-------------------	-------

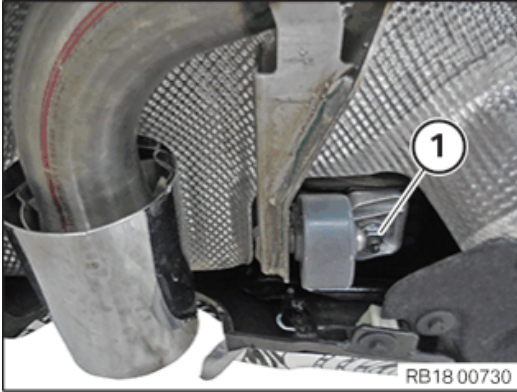

- Tighten nut (1).

#### Rear silencer to bumper support

M8	Tightening torque	19 Nm
----	-------------------	-------

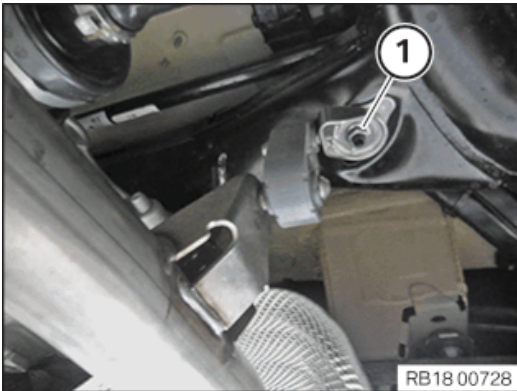

- Tighten nut (1).

#### Exhaust system to rear axle carrier

M8 nut	Tightening torque	19 Nm
--------	-------------------	-------

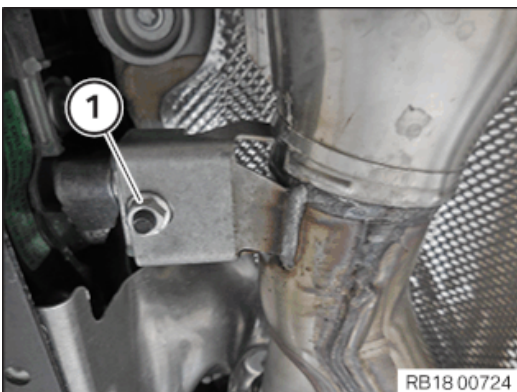

- Tighten nut (1).

#### Exhaust system to transmission

M8	Tightening torque	19 Nm
----	-------------------	-------

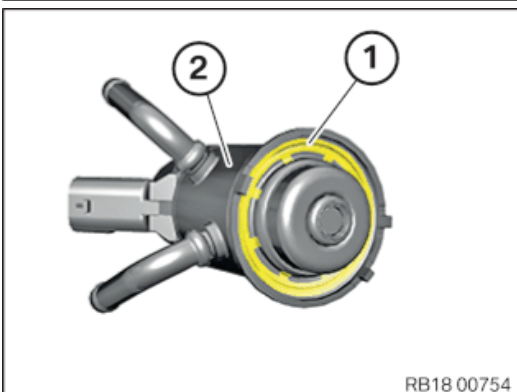

- Renew sealing ring (1) of the SCR metering module (2).

**Parts:** Sealing ring

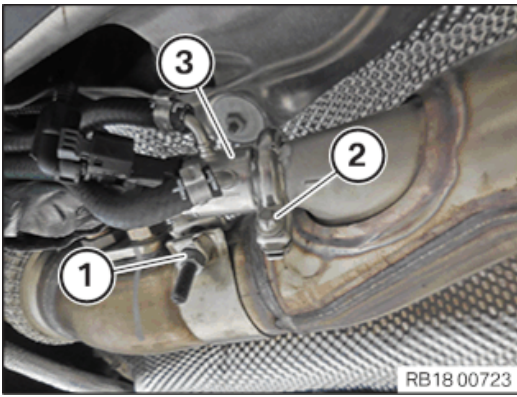

- If necessary, renew clamp (1).

**Parts:** Clamp

- Guide in the exhaust system with the assistance of a second person and connect it to the diesel particulate filter.

- Tighten clamp (1).

#### Exhaust system to diesel particle filter

M8	If necessary, renew clamp.	Tightening torque	26 ±2 Nm
----	----------------------------	-------------------	----------

- Renew the V-clip (2).

**Parts:** V-band clamp

- Install the SCR metering module (3) in the exhaust system.

- Tighten the V-clip (2) of the SCR metering module (3).

#### SCR metering module V-clip to exhaust system

V-band clamp	Renew V-band clamp.	Tightening torque	8 Nm
--------------	---------------------	-------------------	------

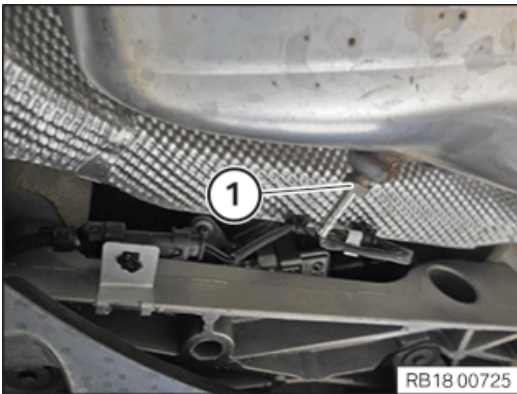

- Install the exhaust temperature sensor (1) in the exhaust system and tighten.

#### Exhaust-gas temperature sensor upstream of SCR catalytic converter

Sensor		Tightening torque	30 Nm
--------	--	-------------------	-------

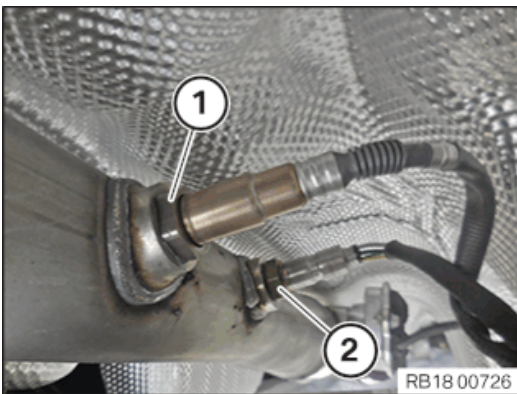

- Install the diesel particulate sensor (1) in the exhaust system and tighten.

#### Diesel particulate sensor to exhaust system

Sensor		Tightening torque	50 Nm
--------	--	-------------------	-------

- Install the nitrogen oxide sensor (2) in the exhaust system and tighten.

#### Nitrogen oxide sensor downstream of SCR catalytic converter

Sensor		Tightening torque	55 Nm
--------	--	-------------------	-------

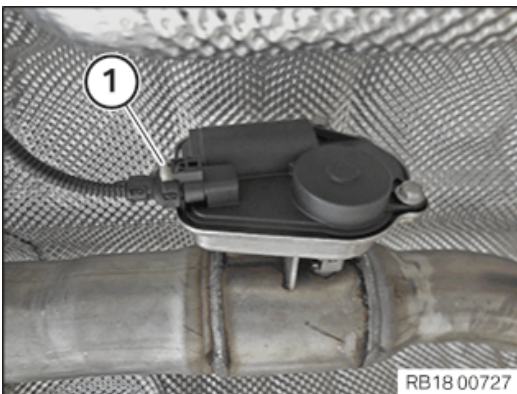

- Connect connectors (1) and lock.

The connector (1) must engage audibly.



The following work step(s) is / are to be carried out if the specified component(s) is/are fitted.

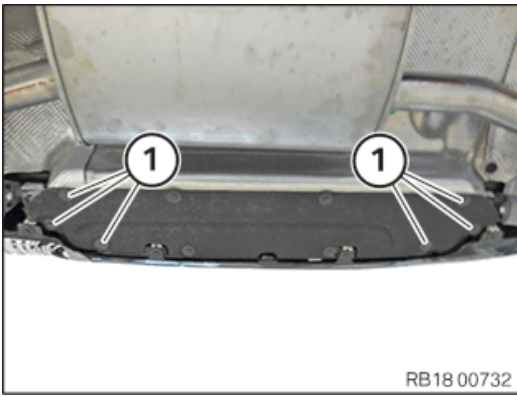

- Install cover.
- Tighten the screws (1).

#### Underbody panelling

Screw	Tightening torque	2,6 Nm
Plastic nut	Tightening torque	2,6 Nm

#### ► If installed: Install the right torsion strut

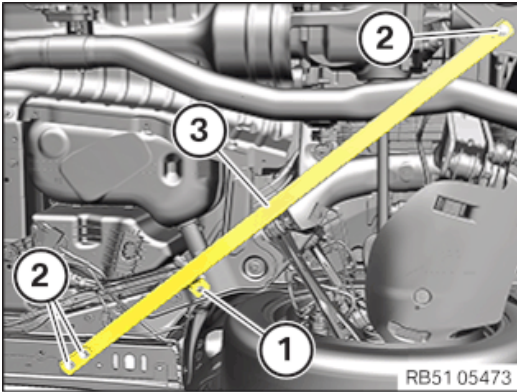

- Thread in torsion strut (3) at right and install.
- Renew screws (2).

#### Parts: Bolts

- Tighten down screws (2).

#### Torsion strut to mounting

M12	Renew screws.	Tightening torque	100 Nm
		Angle of rotation	90 °

- Tighten nut (1).

#### Torsion strut to compression strut

M8	Tightening torque	28 Nm
----	-------------------	-------

### 67 – Install the connecting supports on the tunnel

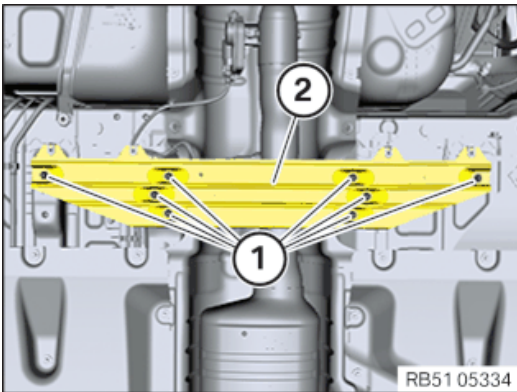

- Position the connecting support (2) on the tunnel.
- Tighten the screws (1).

#### Connecting support on tunnel to body

M8x25 screw	Tightening torque	20 Nm
-------------	-------------------	-------

### 68 – Install tank cover on left and right



The description is for one component only. The procedure is identical for all further components.

#### ► Installing tank cover

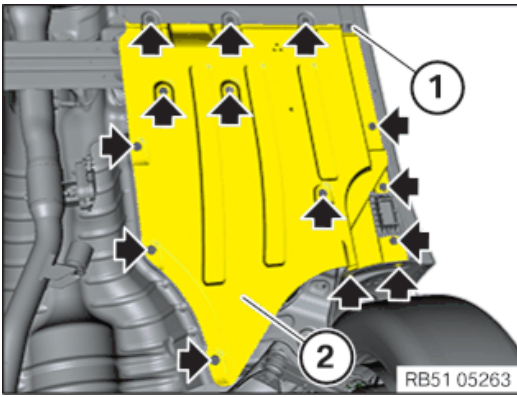

- Guide in tank cover (2) and position correctly.
- Tighten all bolts (arrows) and the plastic nuts (1).

#### Underbody panelling

Screw	Tightening torque	2,6 Nm
Plastic nut	Tightening torque	2,6 Nm

## 69 – Installing the nitrogen oxide sensor upstream of SCR catalytic converter



**Damage to the nitrogen oxide sensor.**

#### Failure of the nitrogen oxide sensor due to contamination or preliminary mechanical damage.

- Remove the protective cap on the sensor only when screwing the sensor on to the exhaust system.
  - Do not use mounting aids, cleaning agents, gaseous and liquid agents in workplaces, storage areas and during transport.
- Contaminations (particles, dust exposure, moisture, etc.) in the area of the plug and socket connection and the sensor must be avoided.
- Mechanical loads (impacts on the sensor or the control unit, tensile loads on the cable, etc.) must be avoided.
- Do not continue using component if these specifications are deviated from.
  - The installation location (exhaust system) must be dry. If necessary, dry the installation location with compressed air.

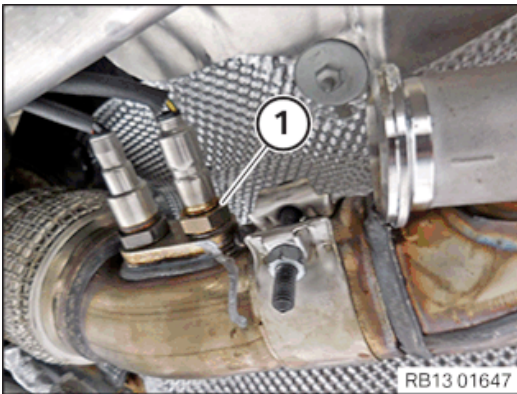

- Feed in and install the nitrogen oxide sensor (1).

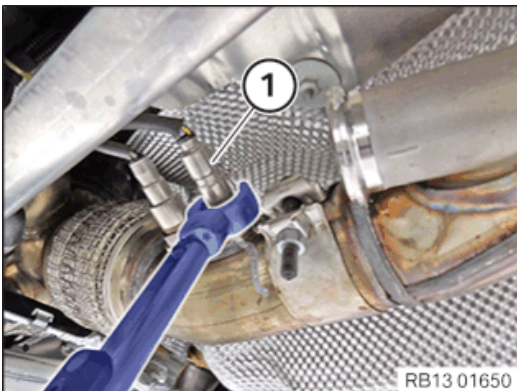

- Tighten the nitrogen oxide sensor (1) using commercially available tools.

#### Nitrogen oxide sensor before SCR catalytic converter

Sensor	Tightening torque	50 Nm
--------	-------------------	-------

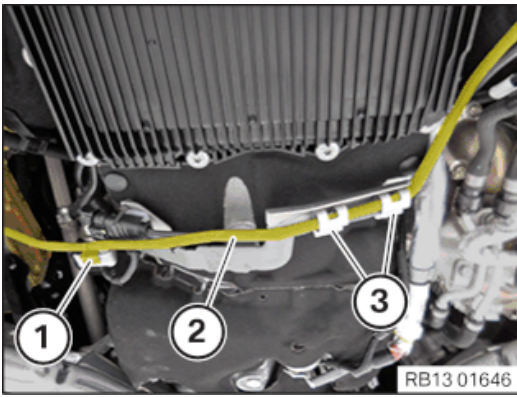

- Secure the cables (2) to the clamps (3).
- Secure clamps (1).

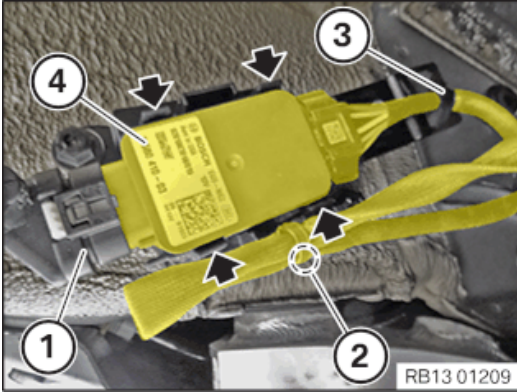

- Clip in the control unit (4) (arrows).
- Fasten the cable in the holder (3).
- Secure the cable holder (2).
- Plug in the connector (1) and lock audibly.

## 70 – Installing the monitoring oxygen sensor after the diesel particulate filter



**Damage to the front oxygen sensor or monitoring oxygen sensor.**

### **Failure of the front oxygen sensor or monitoring oxygen sensor due to contamination or preliminary mechanical damage.**

- Remove the protective cap on the sensor only when screwing the sensor on to the exhaust system.
  - Do not use mounting aids, cleaning agents, gaseous and liquid agents in workplaces, storage areas and during transport.
- Contaminations (particles, dust exposure, moisture, etc.) in the area of the plug and socket connection and the sensor must be avoided.
- Mechanical loads (impacts on the sensor or the control unit, tensile loads on the cable, etc.) must be avoided.
- Do not continue using component if these specifications are deviated from.
  - The installation location (exhaust system) must be dry. If necessary, dry the installation location with compressed air.



New oxygen sensors are to be greased lightly and evenly on the thread.

For oxygen sensors that are reused, the following should be observed:

Lightly and evenly grease the oxygen sensor only on the thread. Do not clean and grease that part of the oxygen sensor which protrudes in the exhaust branch (sensor ceramics).

For additional information see: 11 00 ... Overview of consumables in Electronic Parts Catalogue

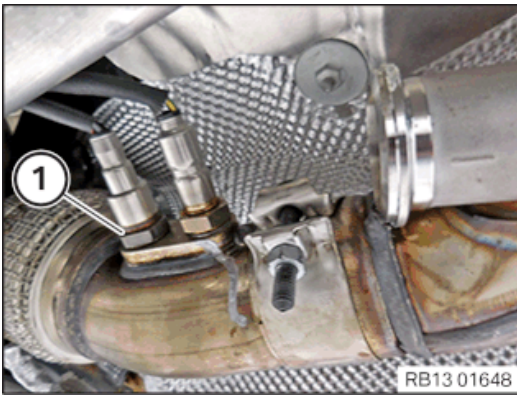

- Insert the monitoring oxygen sensor (1) and install it.

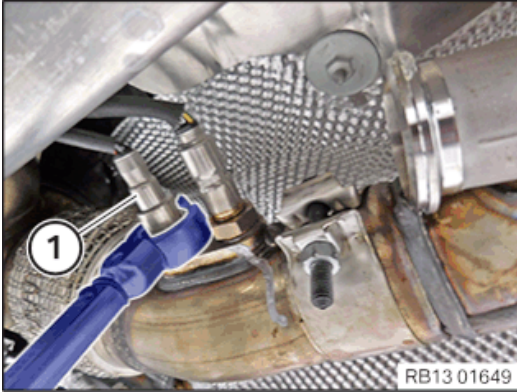

- Tighten the monitoring oxygen sensor (1) with standard tools.

#### Monitoring oxygen sensor

Sensor	Tightening torque	50 Nm

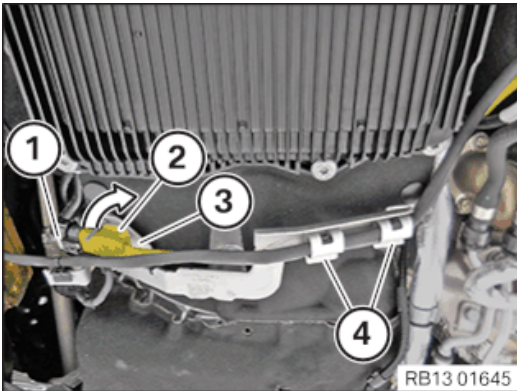

- Fasten the monitoring oxygen sensor to the clamps (4).
  - Secure the connector (2) on the holder (3) in direction of arrow.
  - Connect connectors (1) and lock.
- The connector (1) must engage audibly.

### 71 – Install the exhaust temperature sensor for the exhaust system after the catalytic converter and before the diesel particulate filter



**Damage of exhaust temperature sensor.**  
**Damage to exhaust temperature sensors leads to malfunctions.**

- Make sure that the gauge tip is not damaged.

- Check gauge tip (1) for damage.

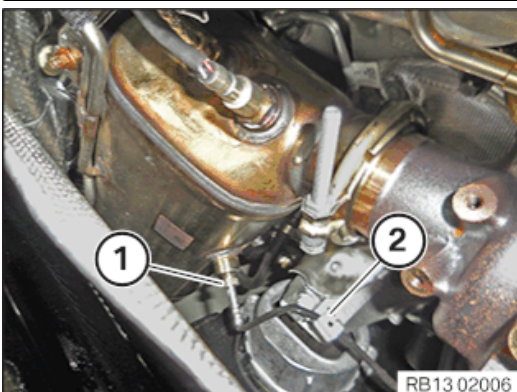

- Feed in and install the exhaust temperature sensor (1).
- Tighten the exhaust temperature sensor (1).

#### Exhaust temperature sensor for the exhaust system after catalytic converter before diesel particulate filter

Sensor	Tightening torque	30 Nm

- Secure the exhaust temperature sensor (1) to the clamp (2).

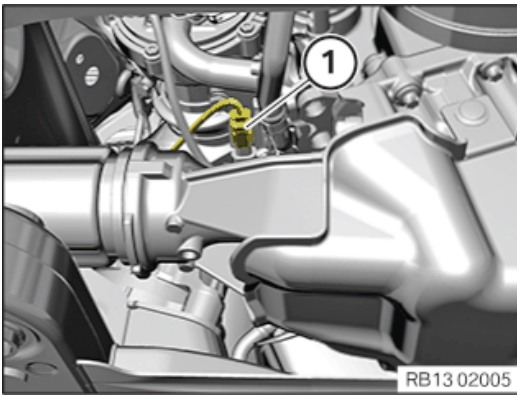

- Connect and lock the connector (1).  
The connector (1) must engage audibly.

## 72 – Installing the front oxygen sensor on the diesel particulate filter



**Damage to the front oxygen sensor or monitoring oxygen sensor.**

**Failure of the front oxygen sensor or monitoring oxygen sensor due to contamination or preliminary mechanical damage.**

- Remove the protective cap on the sensor only when screwing the sensor on to the exhaust system.
  - Do not use mounting aids, cleaning agents, gaseous and liquid agents in workplaces, storage areas and during transport.
- Contaminations (particles, dust exposure, moisture, etc.) in the area of the plug and socket connection and the sensor must be avoided.
- Mechanical loads (impacts on the sensor or the control unit, tensile loads on the cable, etc.) must be avoided.
- Do not continue using component if these specifications are deviated from.
  - The installation location (exhaust system) must be dry. If necessary, dry the installation location with compressed air.



New oxygen sensors are to be greased lightly and evenly on the thread.

For oxygen sensors that are reused, the following should be observed:

Lightly and evenly grease the oxygen sensor only on the thread. Do not clean and grease that part of the oxygen sensor which protrudes in the exhaust branch (sensor ceramics).

For additional information see: 11 00 ... Overview of consumables in Electronic Parts Catalogue

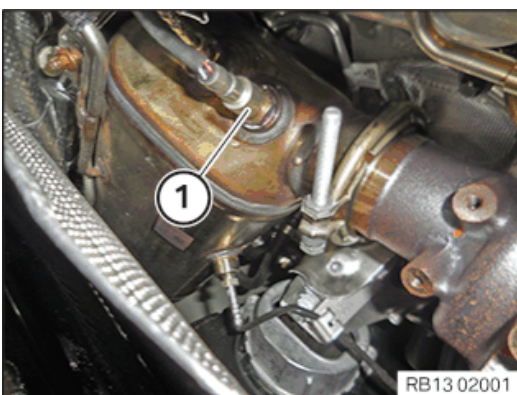

- Insert and install the front oxygen sensor (1).
- Tighten the front oxygen sensor (1) with standard tools.

### Front oxygen sensor to top of diesel particulate filter

Sensor	Tightening torque	50 Nm

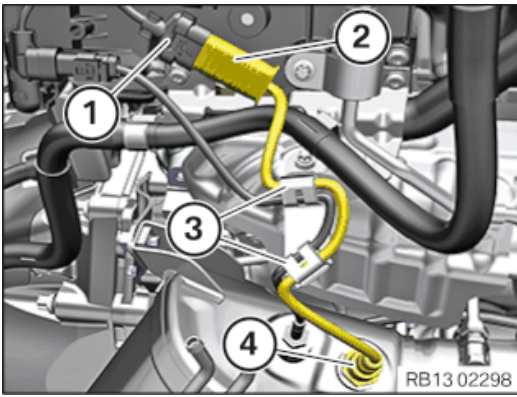

- Fasten the front oxygen sensor (4) to the clamps (3).
  - Connect connectors (2) and lock.
  - Connect connectors (1) and lock.
- The connectors (1) and (2) must audibly engage.

### 73 – Install the exhaust-gas temperature sensor on the diesel particulate filter

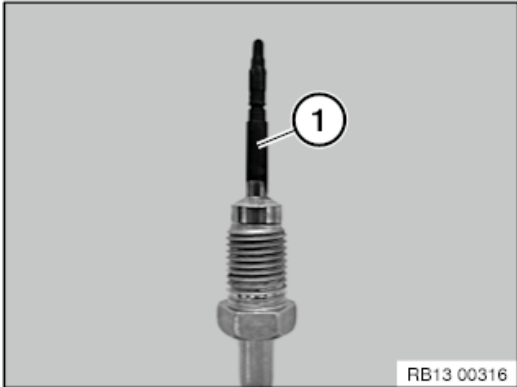

**Damage of exhaust temperature sensor.**  
**Damage to exhaust temperature sensors leads to malfunctions.**

- Make sure that the gauge tip is not damaged.

- Check gauge tip (1) for damage.

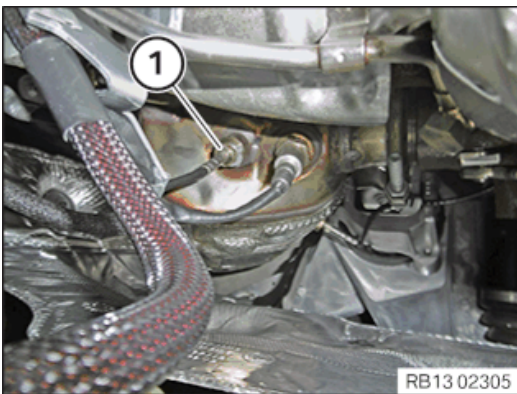

- Feed in and install the exhaust temperature sensor (1).
- Tighten the exhaust temperature sensor (1) with the special tool .

#### **Exhaust-gas temperature sensor to diesel particulate filter**

Sensor	Tightening torque	30 Nm

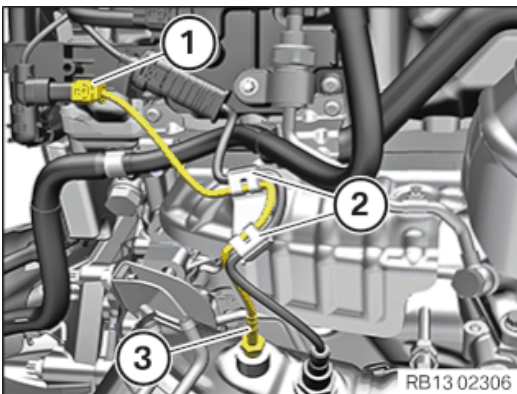

- Secure the exhaust temperature sensor (3) to the clamp (2).
  - Connect connectors (1) and lock.
- The connector (1) must engage audibly.

### 74 – Installing the differential pressure sensor for the diesel particulate filter

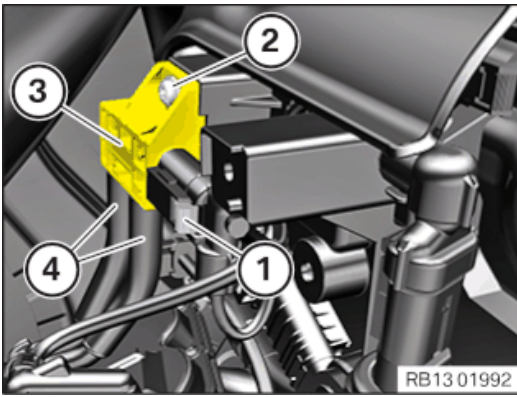

- Feed in and install the differential pressure sensor (3).
- Tighten down screw (2).

#### Differential pressure sensor of diesel particulate filter on cylinder head cover

TS5x20	Tightening torque	4 Nm
--------	-------------------	------

- Check the pressure hoses (4) for hardening and damage, renew if necessary.
- Connect the pressure hoses (4) and secure them using 15 mm to 19 mm screw clamps.

#### Clamp for the pressure hose on the differential pressure sensor

Clamp 15–19mm	Tightening torque	3 Nm
---------------	-------------------	------

- Connect connectors (1) and lock.  
The connector (1) must engage audibly.

## 75 – Fasten air conditioning compressor

### ► Prepare for the installation of the air conditioning compressor

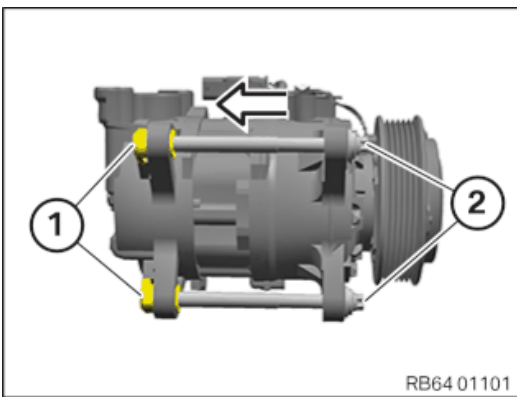

- Screw the screws (2) in the threaded support sleeves (1).
- Slightly press back the threaded support sleeves (1) with the help of screws (2) in the direction of arrow.
- Screw the screws (2) out of the threaded support sleeves (1) once again.

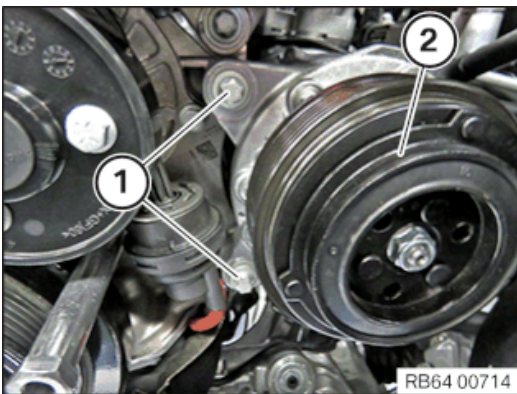

- Correctly position the air conditioning compressor (2).
- Tighten the screws (1).

#### Air conditioning compressor in component carrier

M10	Tightening torque	38 Nm
-----	-------------------	-------

- If required, connect connector.

## 76 – Installing the pressure pipe between the throttle valve and the charge air cooler

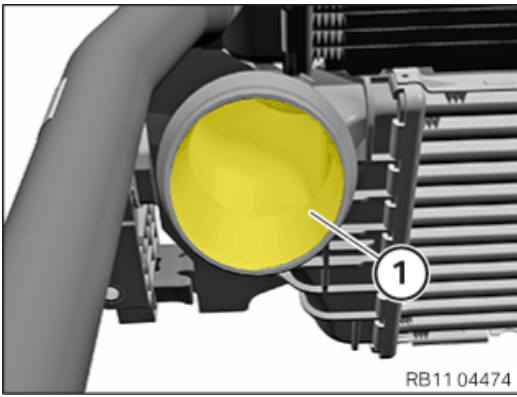

**Contaminant or foreign body.**

**Contamination can result in malfunctions, operating failure or leaks.**

- Adhere to the utmost cleanliness.
- Protect components from contamination e.g. by covering.
- Close off line connections with seal plugs.



- Remove the auxiliary materials for locking the opening (1) of the charge air cooler.
- Check the seal (1) for damage and renew if necessary.

► **Replacing damaged seal**



Do not use pointed or sharp-edged tools for the installation and/or removal.

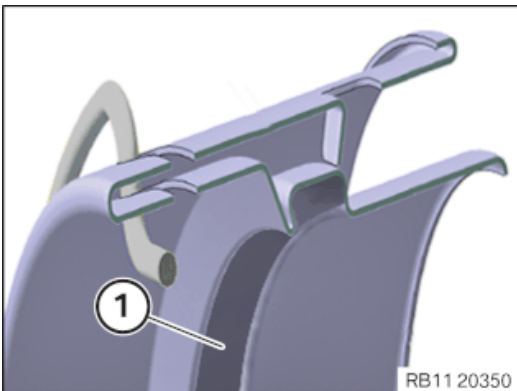

- Remove damaged seal.
- Clean gasket groove (1) with a dry towel.  
The gasket groove (1) must be clean.

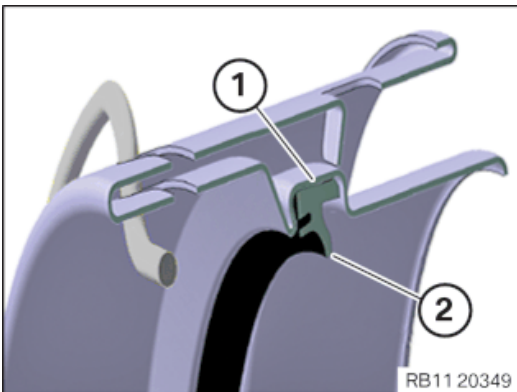

- Renew gasket.
- Parts:** Gasket
- Install seal dry without lubricant or mounting agent.



Incorrect assembly is possible. Ensure correct installation position.

- Feed in and install the seal.
- Make sure the seal is correctly installed in the gasket groove (1).
- Make sure that the sealing lip (2) is directed inwards as shown.

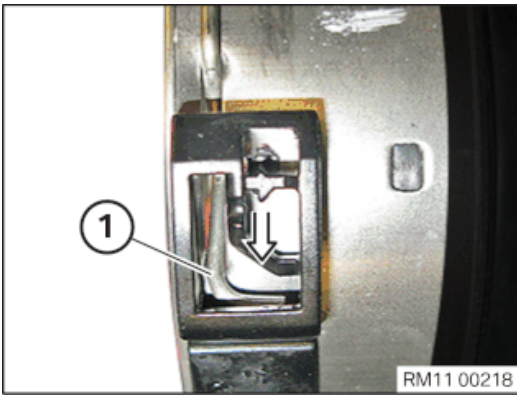

- Let the lock (1) engage audibly in the bracket in the direction of the arrow.

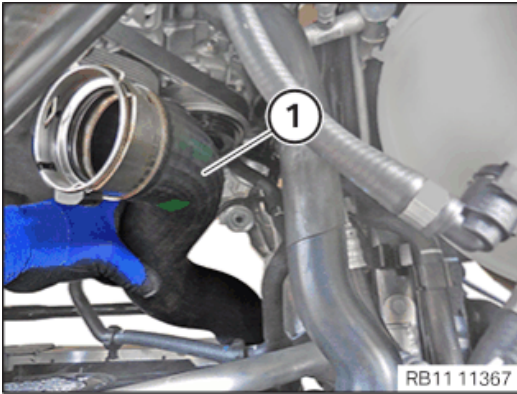

- Guide in and install pressure pipe (1) from above.

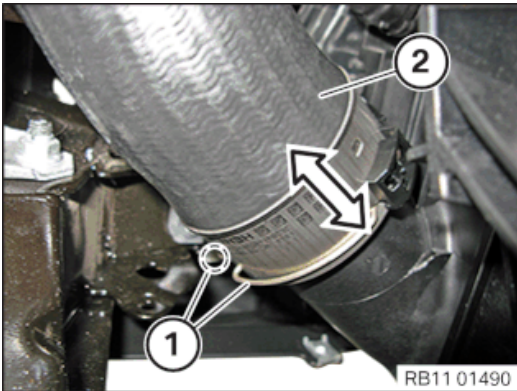

- Attach the pressure pipe (2) to the charge air cooler until the lock (1) engages on both sides.
- Ensure that the lock (1) engages audibly.

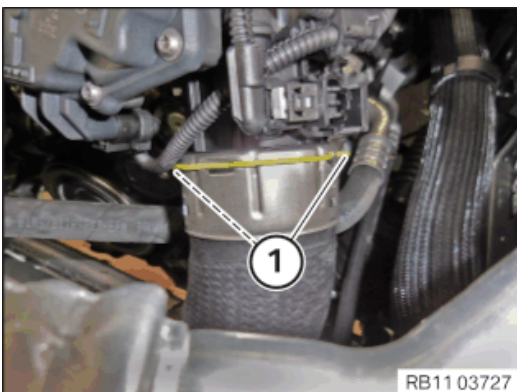

- Insert the pressure pipe in the throttle body until lock (1) engages on both sides.

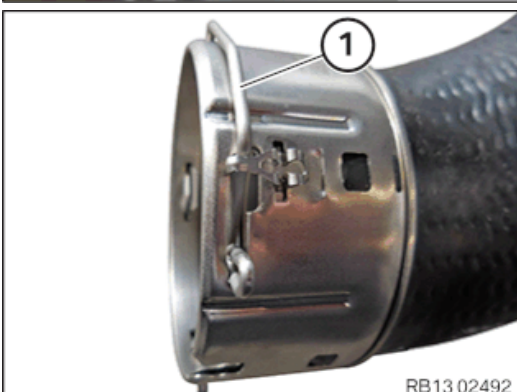

- Check that the locks (1) are correctly seated on the pressure pipe.

## 77 – Install pressure pipe between exhaust turbocharger and charge air cooler

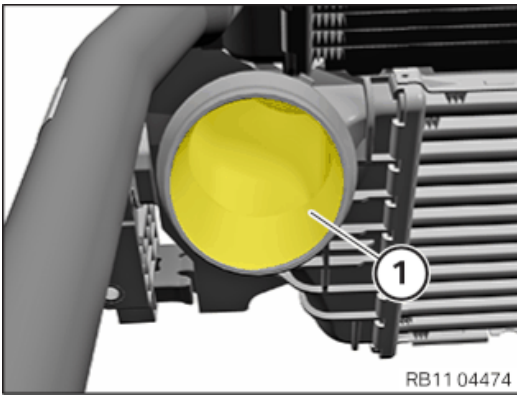

**Contaminant or foreign body.**

**Contamination can result in malfunctions, operating failure or leaks.**

- Adhere to the utmost cleanliness.
  - Protect components from contamination e.g. by covering.
  - Close off line connections with seal plugs.
- Remove the auxiliary materials for locking the opening (1) of the charge air cooler.
  - Check seal (1) for damage, replace seal if necessary.



► **Replacing damaged seal**



Do not use pointed or sharp-edged tools for the installation and/or removal.

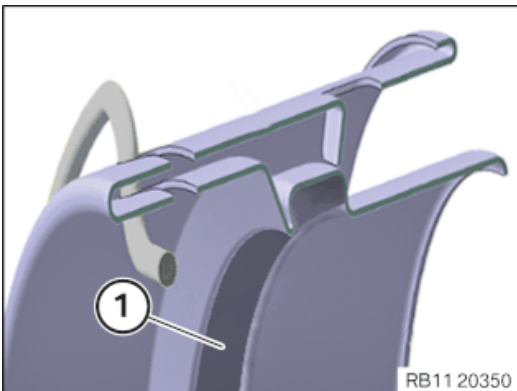

- Remove damaged seal.
- Clean gasket groove (1) with a dry towel.  
The gasket groove (1) must be clean.

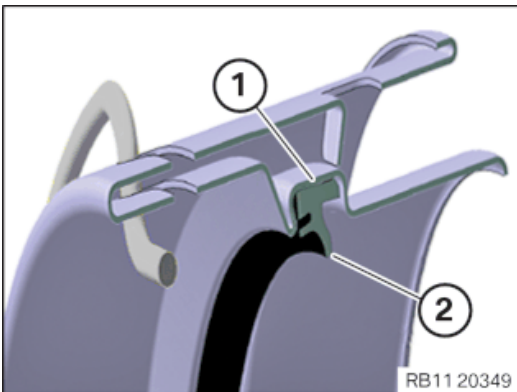

- Renew gasket.
- Parts:** Gasket
- Install seal dry without lubricant or mounting agent.



Incorrect assembly is possible. Ensure correct installation position.

- Feed in and install the seal.
- Make sure the seal is correctly installed in the gasket groove (1).
- Make sure that the sealing lip (2) is directed inwards as shown.

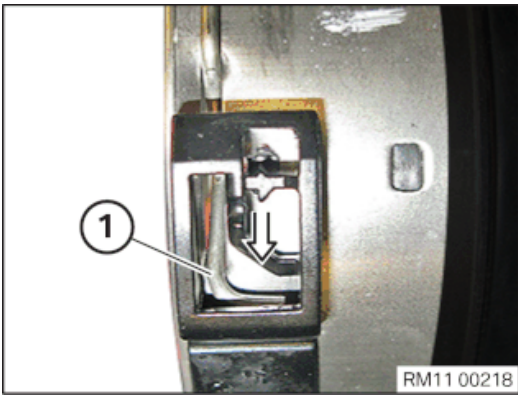

- Engage lock (1) on the holder in direction of arrow.

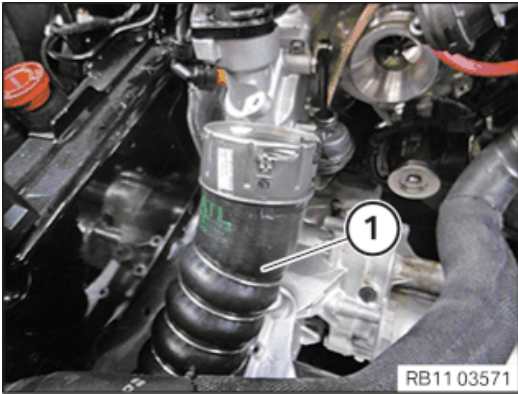

- Install the pressure pipe (1) from the top.

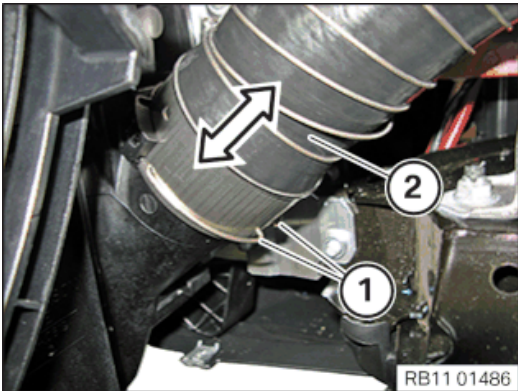

- Attach the pressure pipe (2) to the charge air cooler until the lock (1) engages on both sides.  
The lock (1) must audibly engage.

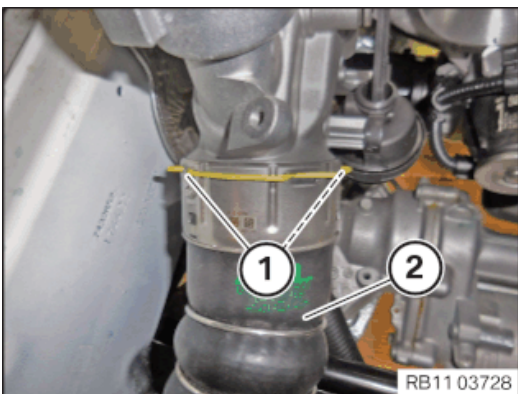

- Place the pressure pipe (2) onto the compressor bypass and ensure that the lock (1) engages audibly.

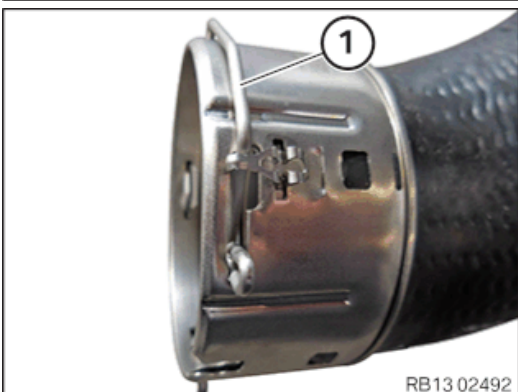

- Check that the locks (1) are correctly seated on the pressure pipe.

## 78 – Install bottom clean air pipe

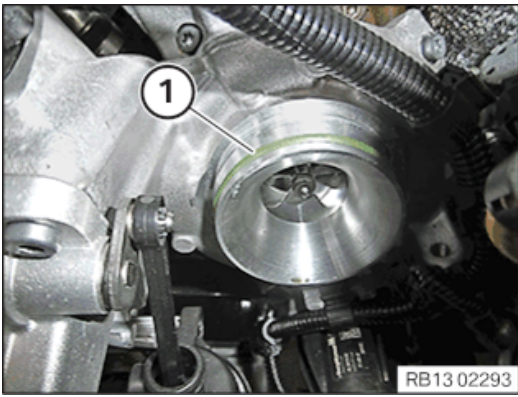

- Check the sealing ring (1) on the exhaust turbocharger for damage and renew if necessary.

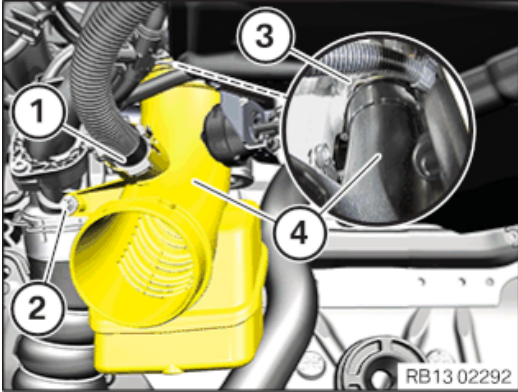

- Feed in the clean air pipe (4) at the bottom and install.
- Attach and lock the clamp (3).  
The clamp (3) must engage audibly.
- Tighten down screw (2).

**Clean air pipe to exhaust turbocharger**

M6X20	Tightening torque	8 Nm
-------	-------------------	------

**79 – Install clean air pipe, top**

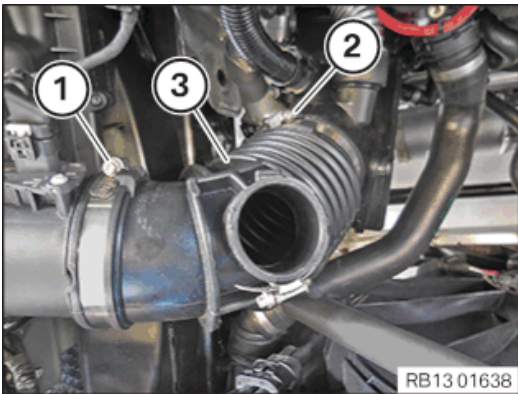

- Thread the top clean air pipe in (3) and install it.
- Tighten clamp (1).

**Clean air pipe to upper section of intake filter housing**

Clamp	Tightening torque	3 Nm
-------	-------------------	------

- Tighten clamp (2).

**Top clean air pipe on the clean air pipe below**

Clamp	Tightening torque	3 Nm
-------	-------------------	------

**80 – Installing intake silencer housing**

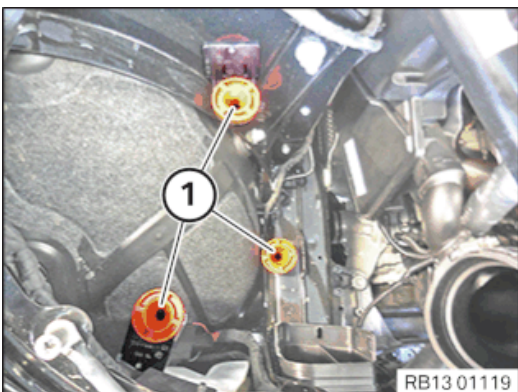

- Check the rubber mount (1) for correct fit.

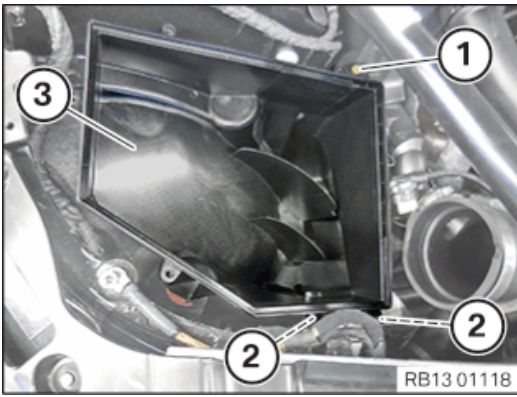

- Feed in lower section of intake filter housing (3) and engage in the rubber mount.
  - If installed: Mount the clamps (2).
- The clamps (2) must engage audibly into the lower section of the intake filter housing (3).
- Tighten down screw (1).

#### Intake silencer housing to resonator

TS5x20	Tightening torque	2.5 Nm
--------	-------------------	--------

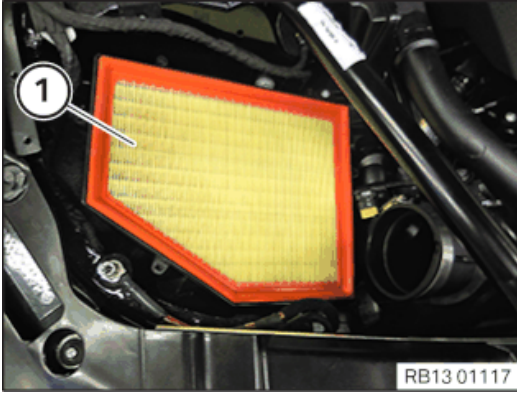

- Install the air filter element (1).

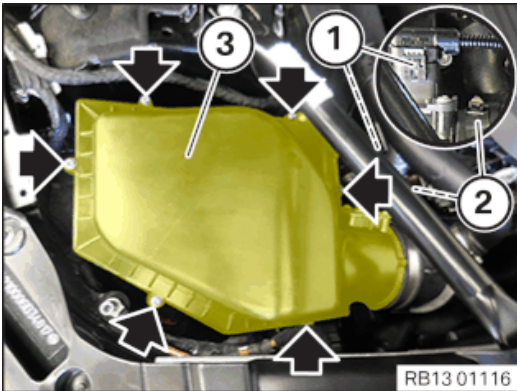

- Insert and install the upper section of the intake filter housing (3).
- Tighten screws (arrows).

#### Intake filter housing upper section to intake filter housing lower section

TS5x20 / TS5x26	Tightening torque	2,5 Nm
--------------------	-------------------	--------

- Tighten clamp (2).

#### Clean air pipe to upper section of intake filter housing

Clamp	Tightening torque	3 Nm
-------	-------------------	------

- Connect and lock the connector (1).
- The connector (1) must engage audibly.

## 81 – Connecting the coolant lines



Make sure that the connections are locked correctly. The locks must engage audibly.

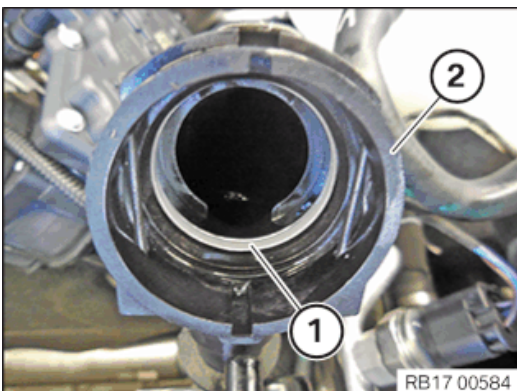

- Check the sealing ring (1) of the coolant line (2) for damage and renew where required.

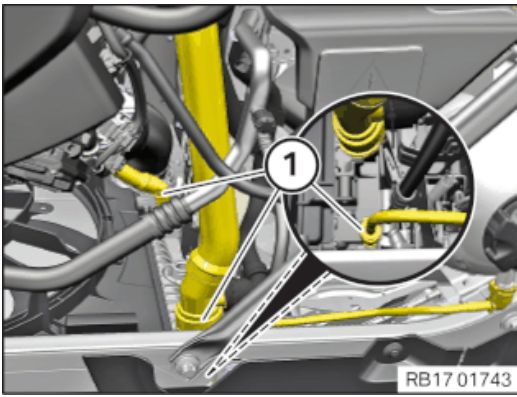

- Connect and lock the coolant lines (1).  
The coolant lines (1) must engage audibly.

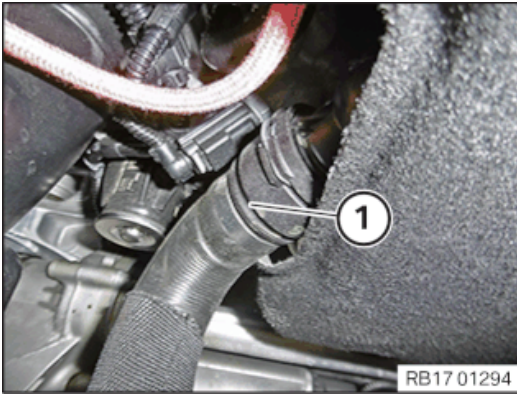

- Connect and lock coolant line (1).  
The coolant line (1) must audibly engage.

## 82 – Installing the drive belt for alternator

**i**

If the drive belt is reused: Mark direction of travel and reinstall drive belt in same direction of travel.

**i**

The drive belt must be replaced if contaminated with coolant- and oil residues.

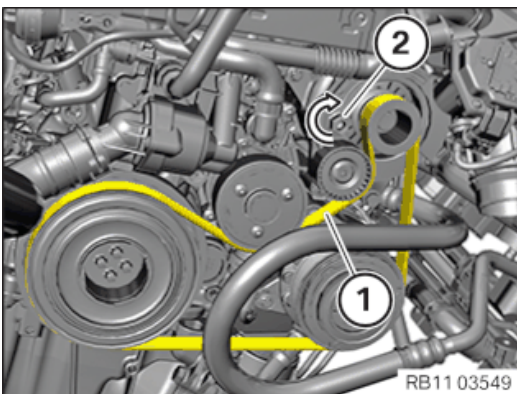

- Check drive belt for alternator (1) for coolant and oil residues and, if necessary, renew it.
- Relieve belt tensioner at hexagon head (2) up to limit position in direction of arrow.
- Install drive belt for alternator (1).

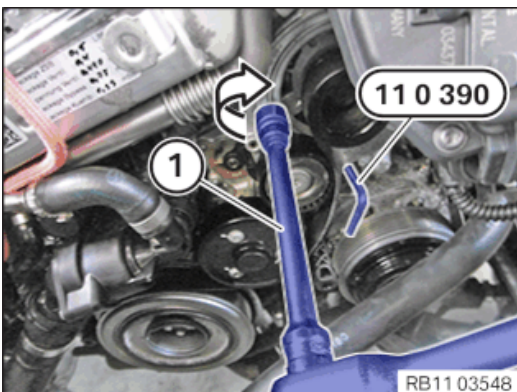

- Increase the preload of the belt tensioner using conventional tool (1) in the direction of arrow until the special tool **0 496 268 (11 0 390)** can be removed.
- Remove special tool **0 496 268 (11 0 390)**.
- Stretch the drive belt for the alternator.

## 83 – Install acoustic cover for the engine, front

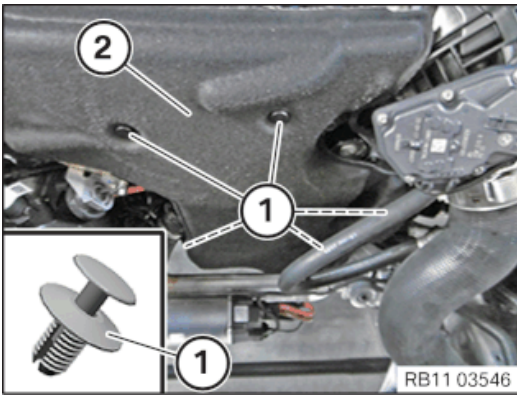

- Feed the acoustic cover (2) in and install.
- Secure the acoustic cover (2) with the expanding rivets (1).

#### 84 – Install fan cowl

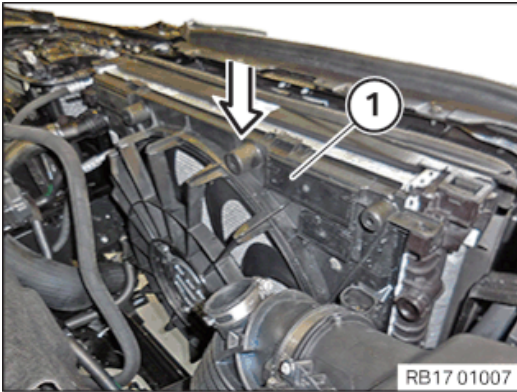

- Feed in and install the fan cowl (1) in the direction of the arrow.

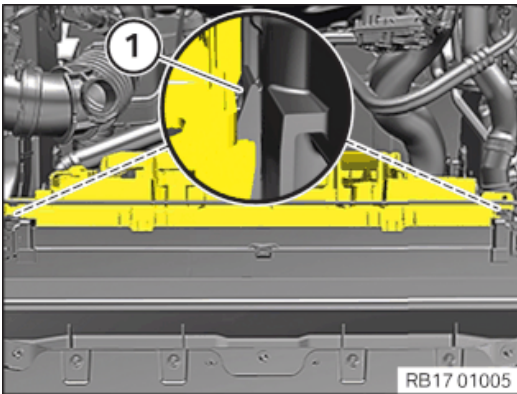

- Lock the locks (1) on the left and right.

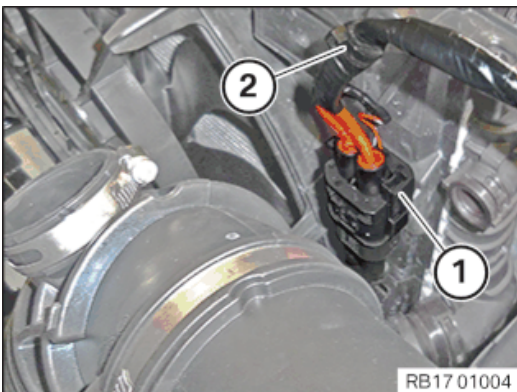

- Connect the connector (1), it should lock audibly.
- Attach the clip (2) on the fan cowl.

#### 85 – Install the rear top cross connection

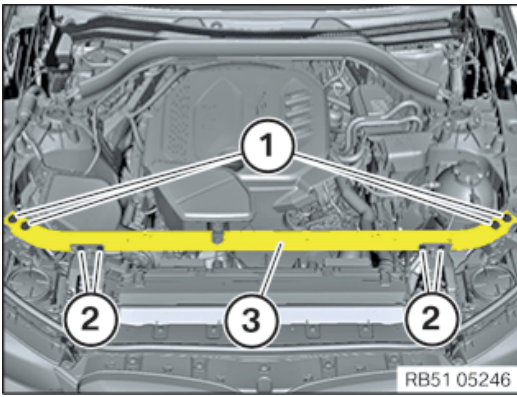

- Thread in the top rear cross connection (3) and position.
- Tighten down screws (2).

#### Top rear cross connection to bonnet lock support

Hexagon screw M6x20	Tightening torque	8 Nm
---------------------	-------------------	------

- Renew screws (1).

**Parts:** Bolts

- Tighten the screws (1).

#### Rear top cross connection to wheel arch carrier support

M10x50 screw	Renew screw.	Jointing torque	56 Nm
		Angle of rotation	90 °

## 86 – Install the fixture of the left and right bonnet seal

### ► Installing the fixture for the bonnet seal on the left

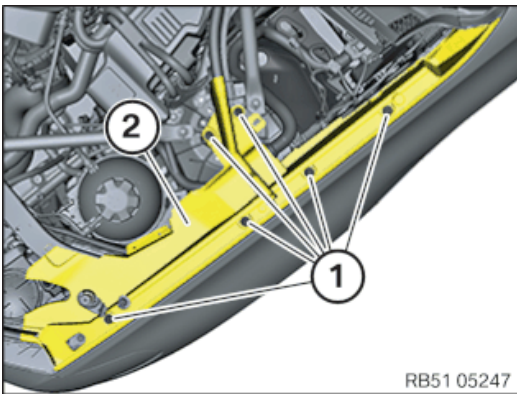

- Position the fixture (2) of the bonnet seal on the left.
- Mount the expanding rivets (1).

### ► Installing the fixture for right bonnet

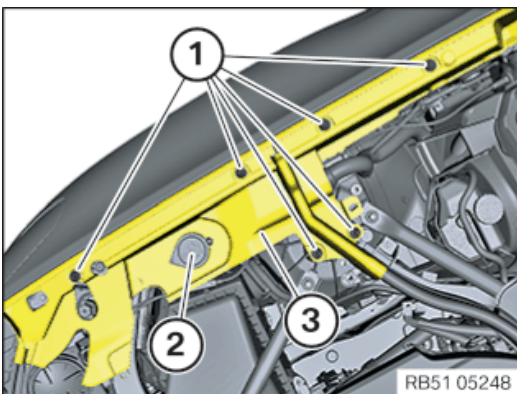

- Position the mounting (3) for the right bonnet seal.
- Install the cover (2) of the washer fluid reservoir.
- Mount the expanding rivets (1).

## 87 – Install the front-end strut on the left and right

### ► Install the left front-end strut

**i**

Driving without the strut brace/front-end strut or tension strut is not permitted.

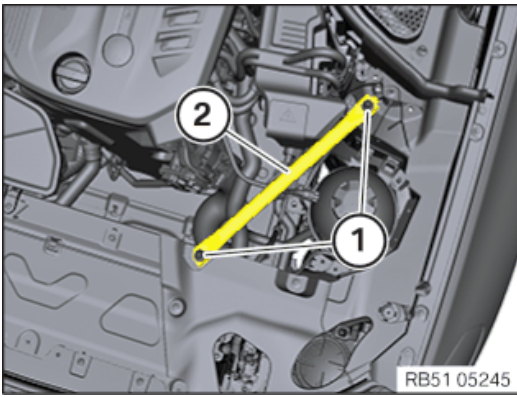

- Install the front-end strut (2).
- Tighten down screw (1).

#### Front end strut

Screw	Tightening torque	56 Nm
-------	-------------------	-------

#### ► Install the right front-end strut



Driving without the strut brace/front-end strut or tension strut is not permitted.

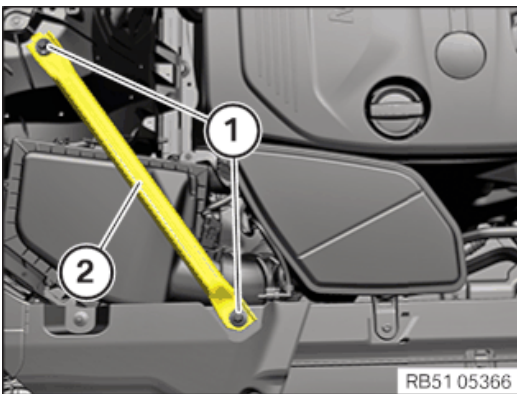

- Install the front-end strut (2).
- Tighten the screws (1).

#### Front end strut

Screw	Tightening torque	56 Nm
-------	-------------------	-------

### 88 – Install front cross connection

#### ► Install front cross connection

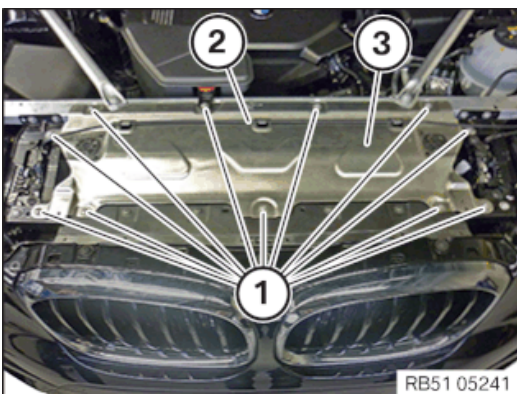

- Feed in cross connection (3).
- Attach the Bowden cable (2).
- Tighten the screws (1).

#### Front cross connection

Screw	Tightening torque	11,8 Nm
-------	-------------------	---------

### 89 – Install the cover in the engine compartment at top left and right



Description is for left component only. Procedure on the right side is identical.

#### ► Install the cover in the engine compartment on top

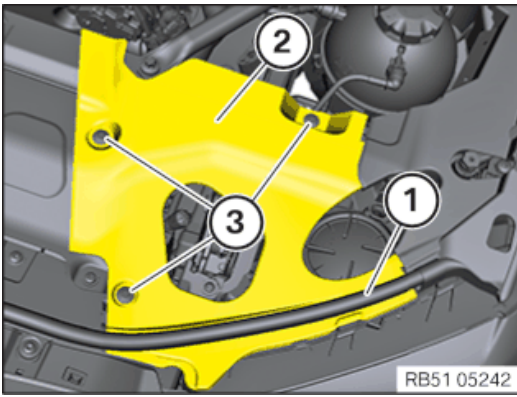

- Insert the cover (2).
- Secure expanding rivet (3).
- Secure the bonnet seal (1) in the area of the cover (2).

## 90 – Install resonator

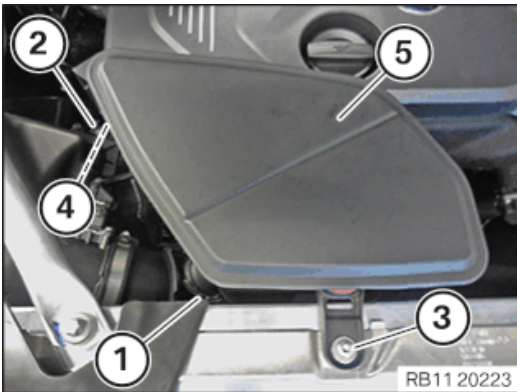

- Insert and install the resonator (5).
- Tighten clamp (1).

### Resonator to clean air pipe

Clamp	Tightening torque	3 Nm
-------	-------------------	------

- Tighten down screw (2).

### Resonator to intake filter housing

Screw	Tightening torque	2,8 Nm
-------	-------------------	--------

- Tighten down screw (3).

### Resonator on the cross connection

	Tightening torque	11,8 Nm
--	-------------------	---------

- Secure clamps (4).

## 91 – Connecting all battery earth leads



- See additional information.

## 92 – Removing the oil filler cap



- Open oil filler cap (1).

## 93 – Topping up the engine oil



**Engine damage caused by excessively filling the engine with engine oil.**

**Filling an excessive quantity of engine oil may cause engine damage.**

- Observe the exact engine oil filling capacity.
- Allow engine oil to drip off when draining.

- Pour in engine oil.

**Engine oil B47D20U1 / B47D20O1 / B47D20T1**

Filling capacity, engine oil change  
with oil filter element

5,5 l

Engine oil: Technically suitable engine oils for BMW Group engines

## 94 – Installing the oil filler cap



- Close oil filler cap (1).

## 95 – Filling and bleed the high-temperature coolant circuit



It is **mandatory** to fill the cooling system before bleeding.

Fill **both** the circuits for high and low-temperature coolant circuits.

- See additional information.

## 96 – Checking/topping up oil level in automatic transmission

### Prerequisite

Vehicle is in a horizontal position.

The vehicle is secured against rolling away.



**Materials harmful to health.**

**Contact with fluids harmful to health!**

- Note and follow safety information on containers.
- Conduct all work in appropriate personal protective equipment only.



To set the correct oil level, it is mandatory that the service function "Transmission control unit: Oil-level adjustment" is carried out with the diagnosis system.



Carry out oil-level adjustment:

Certain fault memory entries may require an oil-level adjustment in the automatic transmission and after repairs have been completed (e.g. exchange of mechatronics, exchange of the converter, exchange of the transmission, automatic transmission oil service).



The automatic transmission fluid specified by BMW must be used for the automatic transmission.

For additional information see: SBS-ANL-SBS1996-240596143\_A14 (automatic transmission fluid for ZF transmissions, etc.)

- Connect diagnosis system.
- Observe the predefined transmission oil temperatures for the oil-level adjustment with the diagnosis system:
  - Initial condition: Transmission oil temperature 30°C to 40°C.
  - Final condition: Transmission oil temperature 40°C to 50°C.
- Call up service function (drive).
- Carry out oil-level adjustment in accordance with the instructions.



- Loosen the oil filler plug (1) using the special tool **2 405 614**.
- Top up automatic transmission fluid according to the instructions in the diagnosis system.

#### GA8HP51Z transmission capacity

min. 9,28 l

Transmission oil: Automatic transmission fluid ATF 3+

#### GA8HP76Z transmission capacity

min. 9,35 l

Transmission oil: Automatic transmission fluid ATF 3+

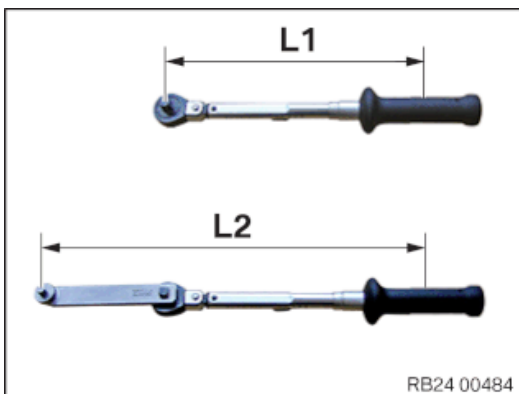

The setpoint torque deviates from the torque to be set when using special tool 2 405 614.

- Converting the setpoint torque into the torque to be set:  
 $(\text{setpoint torque} \times L1) : L2 = \text{Torque to be set}$   
 L1 = Length from the centre of the handle to the reversible ratchet head  
 L2 = Length from the centre of the handle to the engaging of the special tool in the bolt

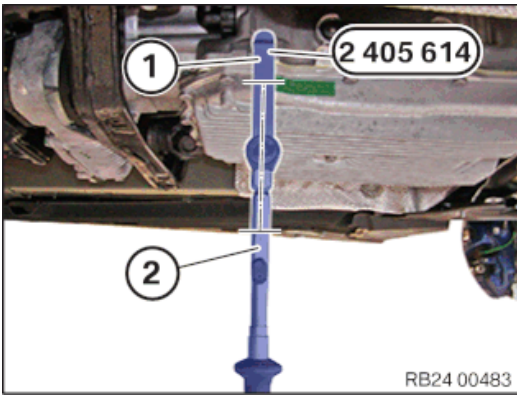

- Renew the oil filler plug (1) and the sealing ring.

**Parts:** Oil filler plug, sealing ring

- Make sure that the special tool **2 405 614** and the torque wrench (2) align while tightening the oil filler plug (1).
- Tighten the oil filler plug (1) with the special tool **2 405 614** and the torque wrench (2).

#### Oil filler plug

M18x1.5

Tightening  
torque

35 Nm

#### 97 – Install the acoustic cover for the injectors

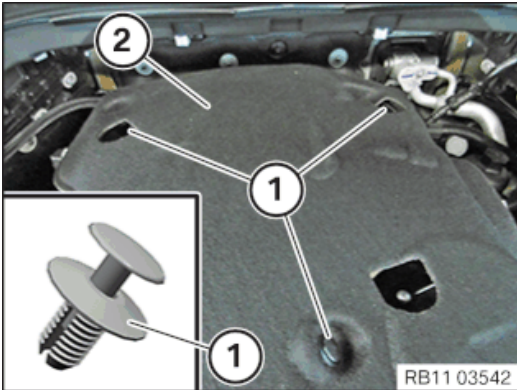

- Feed the acoustic cover (2) in and install.
- **If installed:** Secure the acoustic cover (2) with the expanding rivets (1) .

#### 98 – Install acoustic cover



##### Damage to the acoustic cover/design cover.

**Jerky movements during disassembly and excessive application of force during installation may result in breakage of the acoustic cover/design cover.**

- Disassemble or mount the acoustic cover/design cover carefully.
- Disassemble or mount snap-lock couplings of the ball pivots one after the other.
- Disassemble or mount acoustic cover/design cover only at temperatures >20 °C.
- Use only distilled water as an auxiliary material during installation, no lubricants.

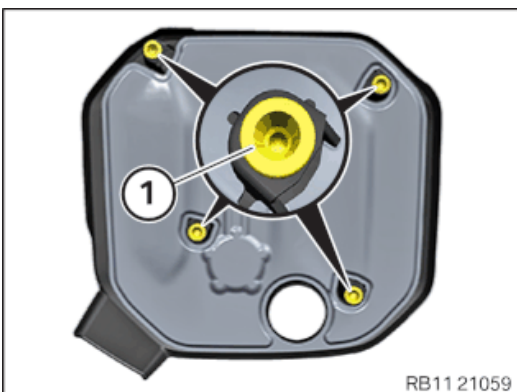

- Check the acoustic cover for correct fit of the rubber mounts (1).



- Clip in the acoustic cover (1) into the holders in the indicated areas.

## 99 – Installing bulkhead upper part

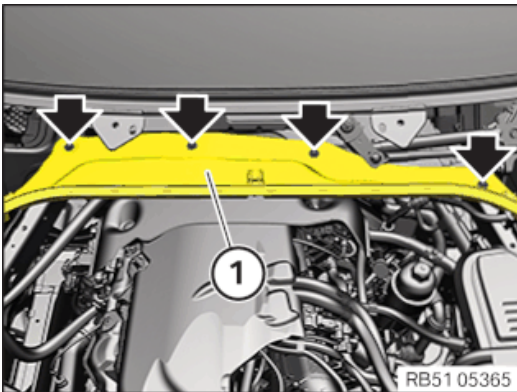

- Feed in and install the bulkhead upper part (1).
- Tighten screws (arrows).

### Bulkhead upper part

Hexagon screw

3 Nm

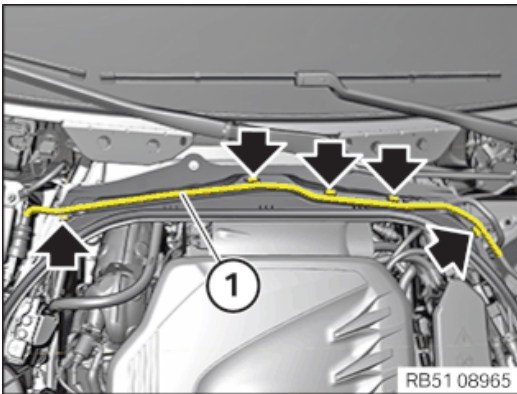

- **Version with mild hybrid technology:**  
Clip in the wire (1) into the holders (arrows).

## 100 – Installing cowl panel cover

**i**

**Before installing** the cowl panel cover it is **mandatory** to check that the 48 V line is routed correctly and fitted tightly.

An incorrectly laid or attached 48 V line can be damaged by the wiper kinematics.

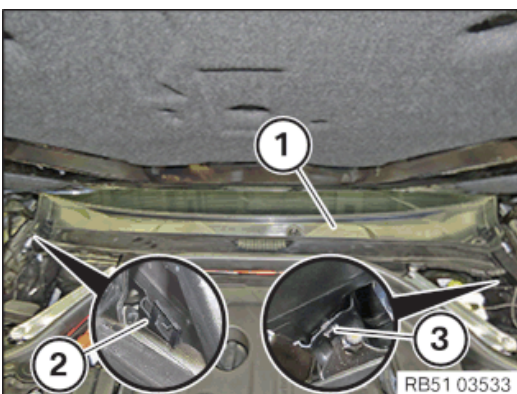

- Starting on the side, push the cowl panel cover (1) into the latch mechanism at the top.
- Engage cowl panel cover (1) into the latch mechanisms (2) and (3).

## 101 – Install the rear right engine compartment cover

### ► Remove the battery cover

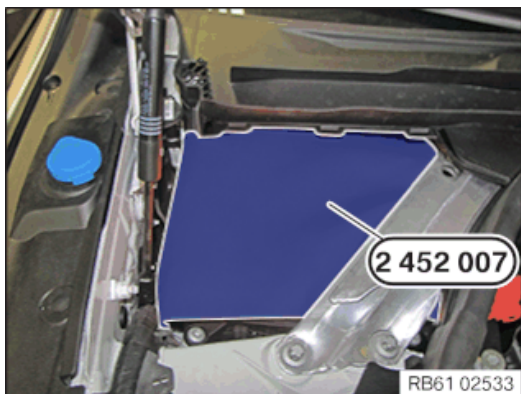

The following work step(s) is / are to be carried out if the specified component(s) is/are fitted.

- Remove the special tool **2 452 007** from the battery.

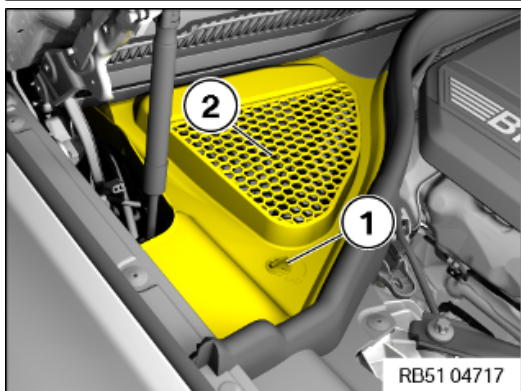

- Install the cover (2).
- Close lock (1).

### 102 – Install the cover of the engine compartment on the rear left

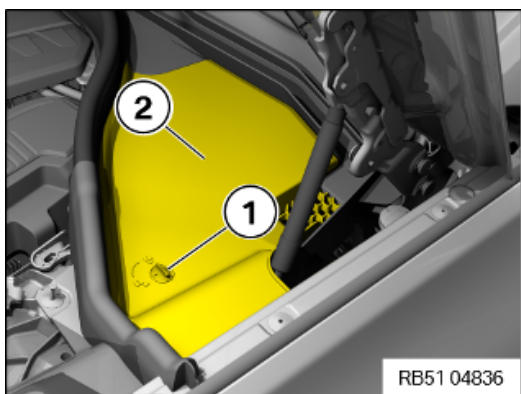

- Install the cover (2).
- Close lock (1).

### 103 – Install left and right wiper arm



Description is for left component only. Procedure on the right side is identical.

### ► Install left and right wiper arm



The wiper system must be in zero position.

After installing the cowl panel cover and before fitting the wiper arm:

Activate the wiper system once to ensure that it has the correct installation position.

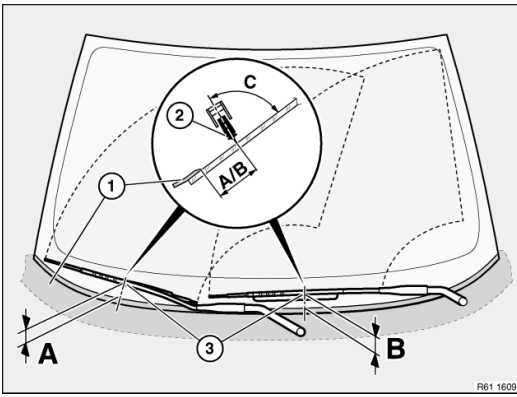

- Connect the wiper arms (3).
- Correctly position the wiper arm (2) in relation to the window edge (1).

#### Distance from window pane edge to wiper blade

Wiper arm right (A)	87,3 mm
Wiper arm left (B)	67,2 mm

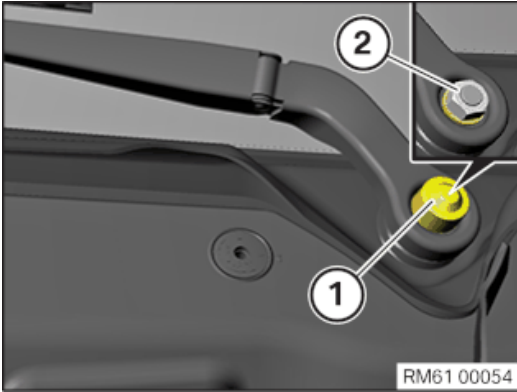

Description is for left component only. Procedure on the right side is identical.

- Tighten nut (2).

#### Windscreen wiper arm

Combination hexagon nut	Tightening torque	35 Nm
-------------------------	-------------------	-------

- Connect the protective cap (1).

#### 104 – Install the seal for the bonnet

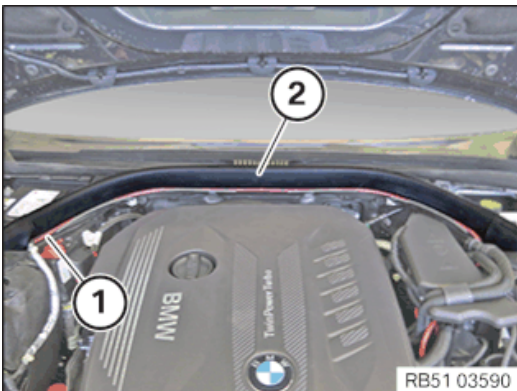

- Press the rear bonnet seal (2) into the guide.
- Feed in cable (1) into the brackets.
- Check that the rear bonnet seal (2) and the cable (1) are seated correctly.

#### 105 – Install the cover of the exhaust system

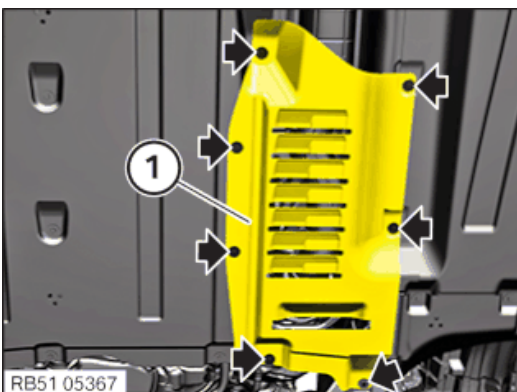

- Guide in and install cover (1).
- Tighten screws (arrows).

#### Cover to transmission cross member

Screw	2,6 Nm
-------	--------

#### 106 – Installing underbody protection at rear

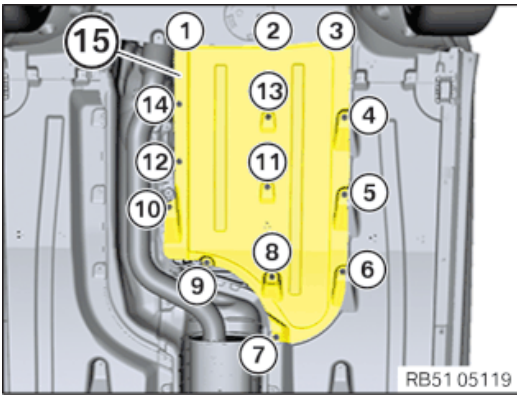

- Guide in the rear underbody protection (15) at an angle toward the front.
- Tighten the screws (1) to (14).

#### Underbody protection

Hexagon screw	Tightening torque	3 Nm
---------------	-------------------	------

### 107 – Install the cover of the steering assembly



To provide a better overview: Schematic diagram with partially hidden components.

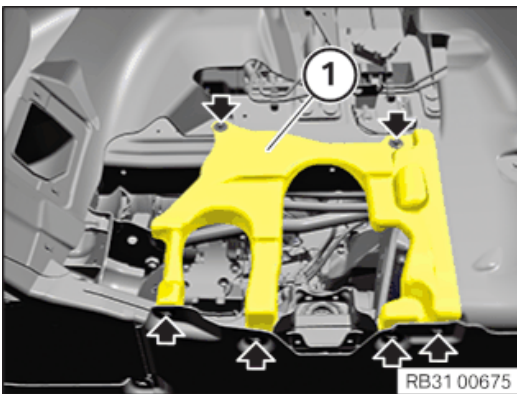

- Insert the cover (1).
- Tighten all bolts (arrows).

#### Cover, steering unit

Screw	Tightening torque	3 Nm
-------	-------------------	------

### 108 – Installing the centre underbody protection

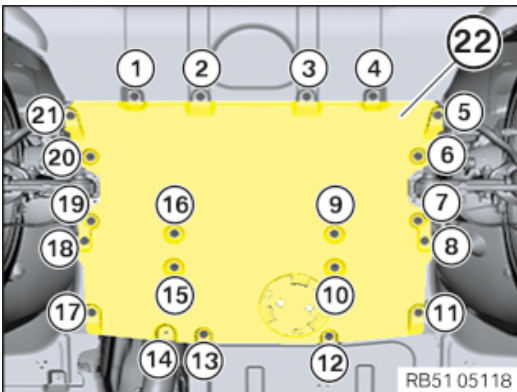

- Guide in the centre underbody protection (22) at an angle toward the front.
- Tighten the screws (1) to (21).

#### Underbody protection

Hexagon screw	Tightening torque	3 Nm
---------------	-------------------	------

### 109 – Install the wheel arch cover on the front left and bottom right



Description is for left component only. Procedure on the right side is identical.

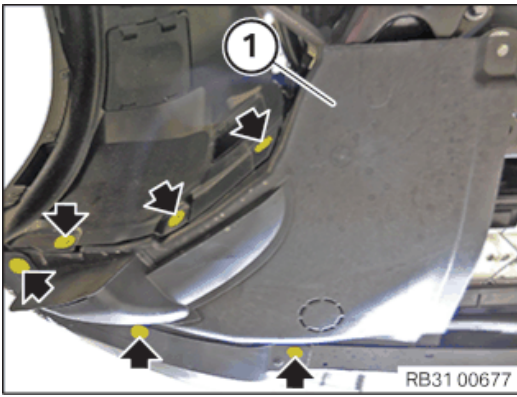

- Guide the wheel arch cover (1) in.
- Tighten all bolts (arrows).

#### Wheel arch cover (screws)

Thermoplastic hexagon screw	Tightening torque	3 Nm
-----------------------------	-------------------	------

### 110 – Installing the front underbody protection

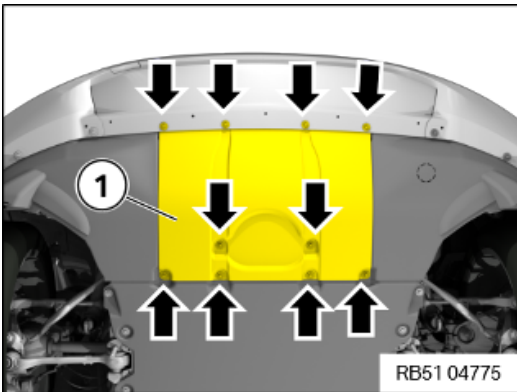

- Insert the front underbody protection (1).
- Tighten screws (arrows).

#### Underbody protection

Hexagon screw	Tightening torque	3 Nm
---------------	-------------------	------

### 111 – Check engine oil level

#### Prerequisite

Vehicle is in a horizontal position.



Please comply with instructions in Owner's Handbook.

- Carry out an electronic oil measurement.
- Top up engine oil if necessary.

#### ► Check engine oil level



Always check the engine oil level when the engine is at operating temperature (engine oil temperature > 70°C).

- Park vehicle on a horizontal surface.
- Stop the engine and wait for 5 minutes.
- Pull out the oil dipstick and wipe off using a lint-free cloth.



Do not pull out or insert the oil dipstick into the guide tube too quickly or slowly.

- Push the oil dipstick into the guide tube up to the limit position and pull it out again.

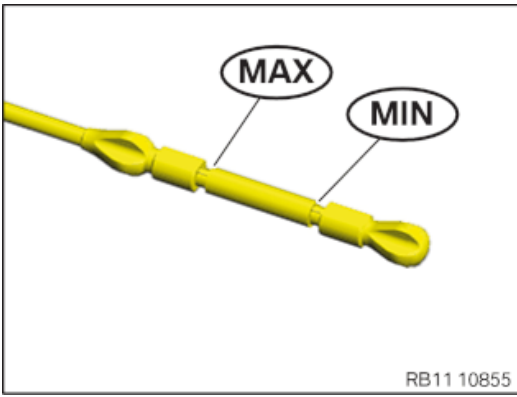

The engine oil level must be between the minimum mark and the maximum mark of the oil dipstick.

- Read the engine oil level on the oil dipstick.
- Top up engine oil if necessary.

**Oil quantity between the two markings MIN and MAX of the oil dipstick**

1.0 l

## 112 – Take bonnet out of the service position



**Shutting bonnet or tailgate.**

**Danger of injury!**

- Support bonnet/tailgate in fully open position with the aid of a suitable device.

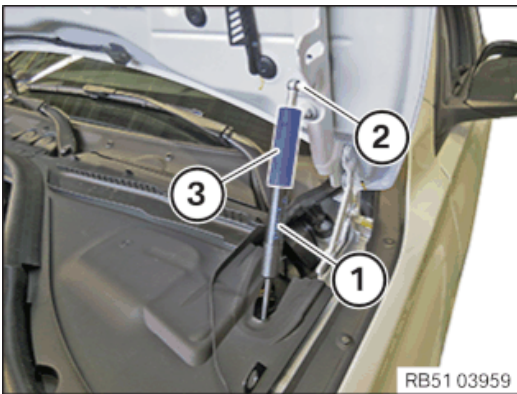

- Support the bonnet by hand.
- Remove the special tool (3) from the ball pin (2).
- Pull off the special tool (3) from the gas pressure spring (1).
- Continue to support the bonnet and repeat the operation on the other side of vehicle.

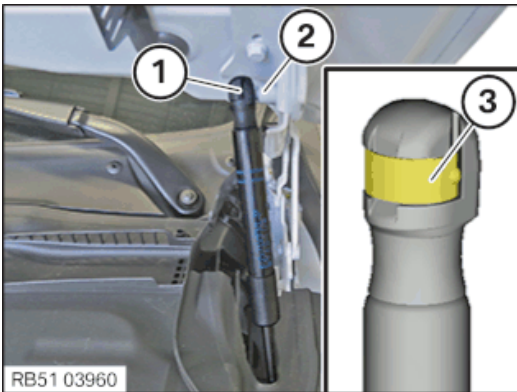

- Check the clamp (3) is fitted correctly.
- Connect ball socket (1) to ball pin (2).
- Continue to support the bonnet and repeat the operation on the other side of vehicle.

## Additional Information

### Overview of Tightening Torques

#### Oil drain plug

Used in step [48](#)

M12x16	Renew the sealing ring.	Tightening torque	25 Nm
--------	-------------------------	-------------------	-------

#### Engine support bracket to engine mount

Used in step [55](#)

M12x1.5x40		Tightening torque	100 Nm
------------	--	-------------------	--------

#### Ground to cylinder head

Used in step [55](#)

M6		Tightening torque	8 Nm
----	--	-------------------	------

<b>Positive battery cable</b>			Used in step <a href="#">55</a>
Positive pole screw		Tightening torque	15 Nm
<b>Torque converter to flywheel</b>			Used in step <a href="#">56</a>
M10	Renew screws.	Tightening torque	56 Nm
<b>Bracket to transmission for diesel particulate filter holder bottom</b>			Used in step <a href="#">56</a> <a href="#">65</a>
M8X20		Tightening torque	19 Nm
<b>Lower holder to diesel particulate filter</b>			Used in step <a href="#">56</a> <a href="#">65</a>
M8		Tightening torque	19 Nm
<b>Coolant line to crankcase/diesel particulate filter</b>			Used in step <a href="#">56</a> <a href="#">57</a>
M6x16			8 Nm
<b>Transmission to engine</b>			Used in step <a href="#">56</a>
M8		Tightening torque	19 Nm
M12		Tightening torque	66 Nm
<b>Transmission oil line to transmission</b>			Used in step <a href="#">56</a>
M6x25	Renew the sealing ring.	Tightening torque	8 Nm
<b>Ground strap to transmission or body</b>			Used in step <a href="#">56</a>
M8		Tightening torque	19 Nm
<b>Transmission cross member to rubber mounts</b>			Used in step <a href="#">56</a>
M12		Tightening torque	100 Nm
<b>Transmission cross member to body</b>			Used in step <a href="#">56</a>
M8		Tightening torque	19 Nm
<b>Starter motor to crankcase</b>			Used in step <a href="#">57</a>
M8x60		Tightening torque	19 Nm
<b>Terminal 50 to starter motor</b>			Used in step <a href="#">57</a>
M6		Tightening torque	7,5 Nm
<b>Battery positive lead to starter</b>			Used in step <a href="#">57</a>
M8		Tightening torque	13,5 Nm
<b>Retaining plates for vehicle underbody cover</b>			Used in step <a href="#">58</a>
Sheet metal nut/plastic nut	Renew nuts.	Tightening torque	3 Nm
<b>Front flexible disc to propeller shaft</b>			Used in step <a href="#">59</a>
M12	Renew screws. Comply with jointing torque and angle of rotation. Tightening via screw.	Jointing torque	55 Nm
		Angle of rotation	90 °
<b>Centre mount to body</b>			Used in step <a href="#">59</a>
M8		Tightening torque	19 Nm

<b>Heat shield to undercarriage</b>			Used in step <a href="#">60</a>
Screws and nuts		Tightening torque	3 Nm
<b>Control unit holder on spring strut dome</b>			Used in step <a href="#">61</a>
Hexagon screw		Tightening torque	8 Nm
<b>Diesel particulate filter V-clip to exhaust turbocharger</b>			Used in step <a href="#">65</a>
V-band clamp	Renew V-band clamp.	Tightening torque	15 Nm
<b>Bracket to diesel particulate filter top</b>			Used in step <a href="#">65</a>
M8		Tightening torque	19 Nm
<b>Coolant lines for SCR metering module</b>			Used in step <a href="#">65</a>
M6X16		Tightening torque	8 Nm
<b>Rear silencer to bumper support</b>			Used in step <a href="#">66</a>
M8		Tightening torque	19 Nm
<b>Exhaust system to rear axle carrier</b>			Used in step <a href="#">66</a>
M8 nut		Tightening torque	19 Nm
<b>Exhaust system to transmission</b>			Used in step <a href="#">66</a>
M8		Tightening torque	19 Nm
<b>Exhaust system to diesel particle filter</b>			Used in step <a href="#">66</a>
M8	If necessary, renew clamp.	Tightening torque	26 ±2 Nm
<b>SCR metering module V-clip to exhaust system</b>			Used in step <a href="#">66</a>
V-band clamp	Renew V-band clamp.	Tightening torque	8 Nm
<b>Exhaust-gas temperature sensor upstream of SCR catalytic converter</b>			Used in step <a href="#">66</a>
Sensor		Tightening torque	30 Nm
<b>Diesel particulate sensor to exhaust system</b>			Used in step <a href="#">66</a>
Sensor		Tightening torque	50 Nm
<b>Nitrogen oxide sensor downstream of SCR catalytic converter</b>			Used in step <a href="#">66</a>
Sensor		Tightening torque	55 Nm
<b>Underbody panelling</b>			Used in step <a href="#">66</a> <a href="#">68</a>
Screw		Tightening torque	2,6 Nm
Plastic nut		Tightening torque	2,6 Nm
<b>Torsion strut to mounting</b>			Used in step <a href="#">66</a>
M12	Renew screws.	Tightening torque	100 Nm
		Angle of rotation	90 °
<b>Torsion strut to compression strut</b>			Used in step <a href="#">66</a>
M8		Tightening torque	28 Nm

<b>Connecting support on tunnel to body</b>			Used in step <a href="#">67</a>
M8x25 screw	Tightening torque		20 Nm
<b>Nitrogen oxide sensor before SCR catalytic converter</b>			Used in step <a href="#">69</a>
Sensor	Tightening torque		50 Nm
<b>Monitoring oxygen sensor</b>			Used in step <a href="#">70</a>
Sensor	Tightening torque		50 Nm
<b>Exhaust temperature sensor for the exhaust system after catalytic converter before diesel particulate filter</b>			Used in step <a href="#">71</a>
Sensor	Tightening torque		30 Nm
<b>Front oxygen sensor to top of diesel particulate filter</b>			Used in step <a href="#">72</a>
Sensor	Tightening torque		50 Nm
<b>Exhaust-gas temperature sensor to diesel particulate filter</b>			Used in step <a href="#">73</a>
Sensor	Tightening torque		30 Nm
<b>Differential pressure sensor of diesel particulate filter on cylinder head cover</b>			Used in step <a href="#">74</a>
TS5x20	Tightening torque		4 Nm
<b>Clamp for the pressure hose on the differential pressure sensor</b>			Used in step <a href="#">74</a>
Clamp 15–19mm	Tightening torque		3 Nm
<b>Air conditioning compressor in component carrier</b>			Used in step <a href="#">75</a>
M10	Tightening torque		38 Nm
<b>Clean air pipe to exhaust turbocharger</b>			Used in step <a href="#">78</a>
M6X20	Tightening torque		8 Nm
<b>Clean air pipe to upper section of intake filter housing</b>			Used in step <a href="#">79</a> <a href="#">80</a>
Clamp	Tightening torque		3 Nm
<b>Top clean air pipe on the clean air pipe below</b>			Used in step <a href="#">79</a>
Clamp	Tightening torque		3 Nm
<b>Intake silencer housing to resonator</b>			Used in step <a href="#">80</a>
TS5x20	Tightening torque		2.5 Nm
<b>Intake filter housing upper section to intake filter housing lower section</b>			Used in step <a href="#">80</a>
TS5x20 / TS5x26	Tightening torque		2,5 Nm
<b>Top rear cross connection to bonnet lock support</b>			Used in step <a href="#">85</a>
Hexagon screw M6x20	Tightening torque		8 Nm
<b>Rear top cross connection to wheel arch carrier support</b>			Used in step <a href="#">85</a>
M10x50 screw	Renew screw.	Jointing torque	56 Nm
		Angle of rotation	90 °
<b>Front end strut</b>			Used in step <a href="#">87</a>
Screw	Tightening torque		56 Nm

<b>Front cross connection</b>		Used in step <a href="#">88</a>
Screw	Tightening torque	11,8 Nm
<b>Resonator to clean air pipe</b>		Used in step <a href="#">90</a>
Clamp	Tightening torque	3 Nm
<b>Resonator to intake filter housing</b>		Used in step <a href="#">90</a>
Screw	Tightening torque	2,8 Nm
<b>Resonator on the cross connection</b>		Used in step <a href="#">90</a>
	Tightening torque	11,8 Nm
<b>Oil filler plug</b>		Used in step <a href="#">96</a>
M18x1.5	Tightening torque	35 Nm
<b>Bulkhead upper part</b>		Used in step <a href="#">99</a>
Hexagon screw		3 Nm
<b>Windscreen wiper arm</b>		Used in step <a href="#">103</a>
Combination hexagon nut	Tightening torque	35 Nm
<b>Cover to transmission cross member</b>		Used in step <a href="#">105</a>
Screw		2,6 Nm
<b>Underbody protection</b>		Used in step <a href="#">106</a> <a href="#">108</a> <a href="#">110</a>
Hexagon screw	Tightening torque	3 Nm
<b>Cover, steering unit</b>		Used in step <a href="#">107</a>
Screw	Tightening torque	3 Nm
<b>Wheel arch cover (screws)</b>		Used in step <a href="#">109</a>
Thermoplastic hexagon screw	Tightening torque	3 Nm

## Overview of Special Tools

### 0 493 200 (51 2 160) Support

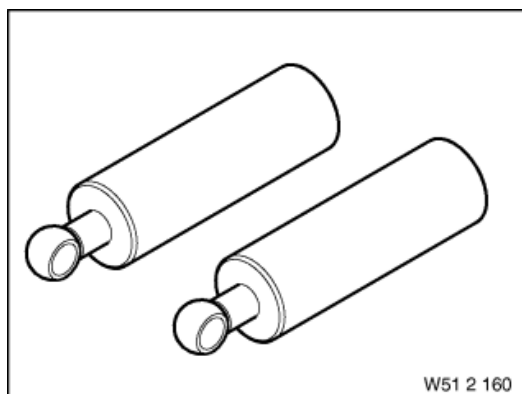

<b>Common</b>		Used in step <a href="#">1</a>
Usage	(Bonnet support (2 x)) For retaining engine compartment lid in working position	
Included in the tool or work		
Storage location	C1	
Replaced by		
In connection with		
SI-Number	01 02 98 (302)	

### 2 452 007 Cover

<b>Common</b>		Used in step <a href="#">11</a> <a href="#">101</a>
Usage	During the disassembly of the bonnet, the vehicle grounding wire may come into contact with the	



positive battery wire. A protective mat must be used to prevent this.

Included in the tool or work

Storage location Individual

Replaced by

In connection with

SI-Number 02 21 17 (452)

### 0 496 268 (11 0 390) Pin

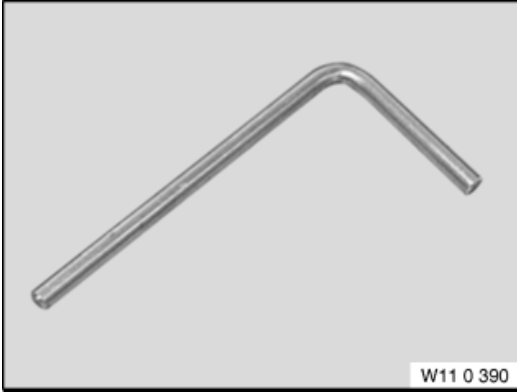

#### Common

Used in step [25](#) [82](#)

Usage (roll pin) For securing new tensioning pulley (poly-V belt)

Included in the tool or work

Storage location B24

Replaced by

In connection with

SI-Number 01 15 07 (390)

### 2 219 012 Hydraulic lifter



#### Common

Used in step [53](#)

Usage For raising and lowering various vehicle components.

Included in the tool or work

Storage location

Replaced by

In connection with

SI-Number 01 05 90 (207)

### 0 495 498 (23 4 050) Fixture

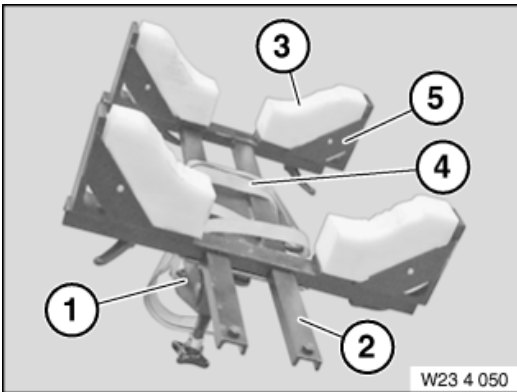

#### Common

Used in step [53](#)

Usage (universal gearbox holder) Support for removing and installing manual gearboxes and automatic transmissions for BMW & RR.

Included in the tool or work

Storage location Individual

Replaced by

In connection with

SI-Number 01 07 06 (256)

#### Consisting of

Pos	BMW Order number	Replaced by	Designation	In Connection with
3	<a href="#">0 495 549 (23 4 053)</a>		<b>Insert</b> (foam inserts (1 set = 4 pcs.))	

1 [0 495 547 \(23 4 051\)](#)

**Joint**

Available only as a complete tool set 23 4 050 (83 30 0 495 498) - as of 16.07.12.

2 [0 495 548 \(23 4 052\)](#)

**Frame**

(Basic frame) Available only as a complete tool set 23 4 050 (83 30 0 495 498) - as of 16.07.12.

4 [0 495 550 \(23 4 054\)](#)

**Belt**

(Tensioning strap) Available only as a complete tool set 23 4 050 (83 30 0 495 498) - as of 16.07.12.

5 [0 496 018 \(23 4 055\)](#)

**Fixture**

(Fixture for foam insert) Available only as a complete tool set 23 4 050 (83 30 0 495 498) - as of 16.07.12.

**0 493 380 (11 6 480) Connector**

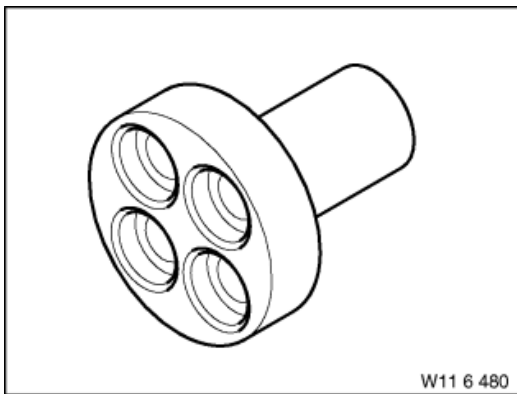

**Common**

Used in step [53](#) [56](#)

Usage For turning over engine at crankshaft hub (vibration absorber).

Included in the tool or work

Storage location

Replaced by

In connection with

SI-Number 01 11 98 (338)

**0 494 478 (24 4 161) Basic body**

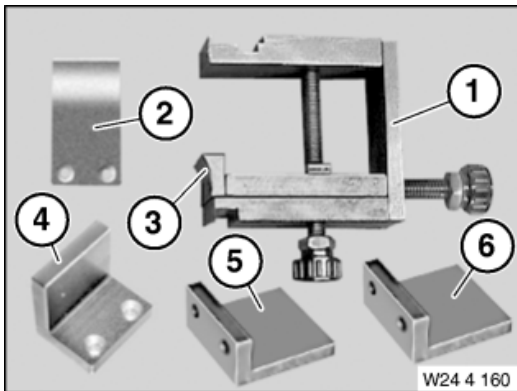

**Common**

Used in step [53](#)

Usage

Included in the tool or work 0 494 451

Storage location B45

Replaced by

In connection with

SI-Number

**0 494 965 (24 4 165) Shaped element**

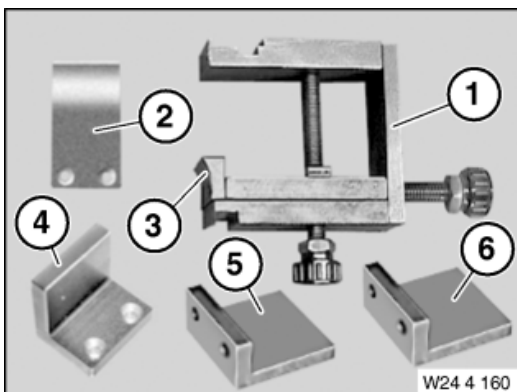

**Common**

Used in step [53](#)

Usage Gearbox: GA6 HP19 in E87, E90 Discontinued, available as part of set of special tools only

Included in the tool or work 0 494 451

Storage location B45

Replaced by

In connection with

SI-Number 01 15 04 (117)

**0 494 451 (24 4 160) Holder**

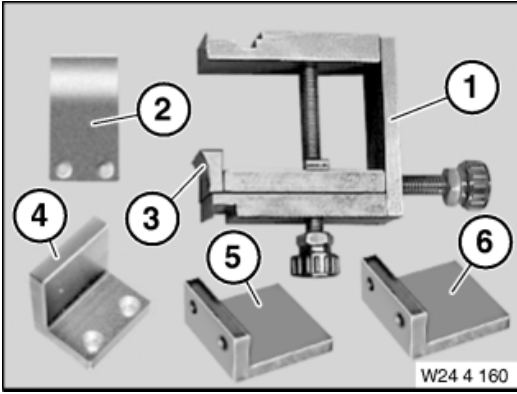

### Common

Used in step [53](#) [56](#)

Usage	For securing converter during removal and installation of transmission
Included in the tool or work	
Storage location	B45
Replaced by	
In connection with	
SI-Number	01 11 02 (908)

### Consisting of

Pos	BMW Order number	Replaced by	Designation	In Connection with
2	<a href="#">0 494 479 (24 4 162)</a>		<b>Shaped element</b> For converter version N73 discontinued, available as part of set of special tools only	
5	<a href="#">0 494 965 (24 4 165)</a>		<b>Shaped element</b> Transmission: GA6 HP19 in E87, E90 Discontinued, available as part of set of special tools only	
3	<a href="#">0 494 477 (24 4 163)</a>		<b>Shaped element</b> For converter version M57TU discontinued, available as part of set of special tools only	
1	<a href="#">0 494 478 (24 4 161)</a>		<b>Basic body</b>	
4	<a href="#">0 494 622 (24 4 164)</a>		<b>Shaped element</b> For converter version M54 discontinued, available as part of set of special tools only	
6	<a href="#">0 496 061 (24 4 166)</a>		<b>Shaped element</b> Transmission: GA6L45R (GM6) in E83 / N52K Discontinued, available as part of set of special tools only	

### 0 494 213 (24 2 390) Cap



### Common

Used in step [53](#) [56](#)

Usage	(protective cap) For sealing off the guide sleeve of the transmission connector
Included in the tool or work	
Storage location	C49
Replaced by	
In connection with	
SI-Number	01 14 01 (766)

### 2 220 718 Workshop crane

### Common

Used in step [54](#)

Usage	WSK 1000
-------	----------



Included in the tool or work

Storage location Individual

Replaced by

In connection with

SI-Number 06 01 11 (701)

### 0 490 561 (11 0 000) Lifting gear

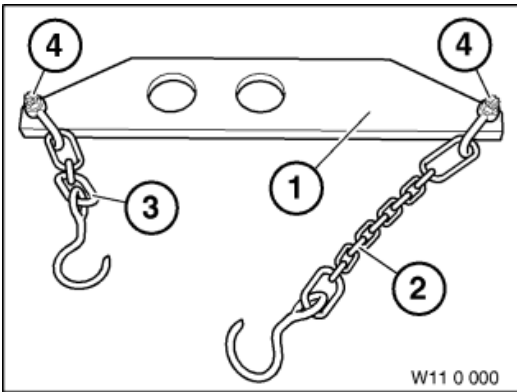

**Common** Used in step [54](#) [55](#)

Usage (Hoisting gear) For removing and installing engines. As of 08/2011 only available as a complete set. Delivered with TÜV inspection certificate and operating instructions. No delivery of separate parts.

Included in the tool or work

Storage location Individual

Replaced by

In connection with

SI-Number 01 13 94 (888)

#### Consisting of

Pos	BMW Order number	Replaced by	Designation	In Connection with
4	<a href="#">0 490 565 (11 0 009)</a>		<b>Shackle</b> (Shackle) 2 pieces. As of 08/2001, only available as a complete set via 11 0 000 = 0490561. Delivered with TÜV inspection certificate and operating instructions.	
1	<a href="#">0 490 562 (11 0 001)</a>		<b>Lifting gear</b> (Cross member) As of 08/2001, only available as a complete set via 11 0 000 = 0490561. Delivered with TÜV inspection certificate and operating instructions.	
2	<a href="#">0 490 563 (11 0 002)</a>		<b>Chain</b> (Chain) Equipment specification: long As of 08/2001, only available as a complete set via 11 0 000 = 0490561. Delivered with TÜV inspection certificate and operating instructions.	
3	<a href="#">0 490 564 (11 0 003)</a>		<b>Chain</b> (Chain) Equipment specification: short As of 08/2001, only available as a complete set via 11 0 000 = 0490561. Delivered with TÜV inspection certificate and operating instructions.	

### 0 490 189 (00 2 550) Measurement aid

**Common** Used in step [56](#)

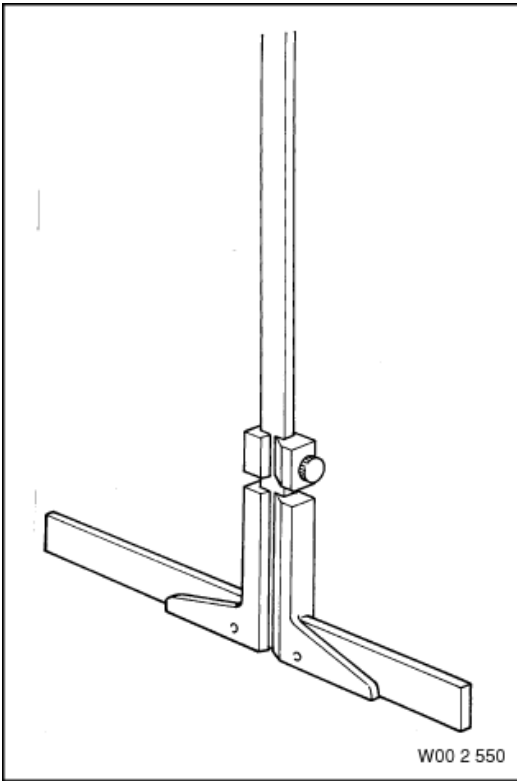

Usage (Depth gauge) E.g. for determining side clearance of transmission shaft and basic adjustment dimension for installing bevel pinion in rear axle final drives

Included in the tool or work

Storage location A4

Replaced by

In connection with

SI-Number

**0 491 667 (24 1 110) Socket wrench insert**

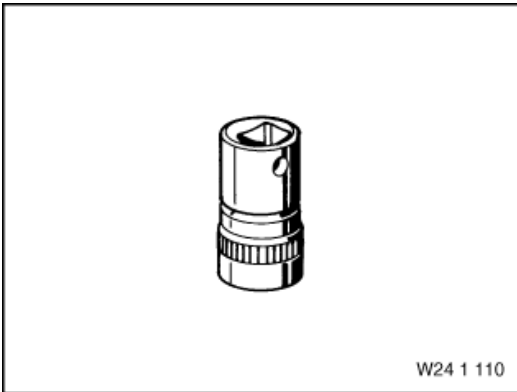

**Common** Used in step [56](#)

---

Usage Loosening and fastening the converter fastener

Included in the tool or work

Storage location A14

Replaced by

In connection with

SI-Number 01 04 86 (566)

**0 490 504 (00 9 120) Torque angle measuring dial**



**Common** Used in step [59](#)

---

Usage For torsion angle adjustment of cylinder head bolts (all engines) And reinforcement plate front axle support E46

Included in the tool or work

Storage location A4

Replaced by

In connection with

SI-Number

**2 405 614 Socket wrench**

**Common** Used in step [96](#)

---

Usage For opening and closing the oil filler plug. Contour-graphic silhouette foil is included in delivery specification. Further information on the contour-graphic silhouette foil can be found in service information 00 22 13 (969). Replaced by 2455997

Included in the tool or work

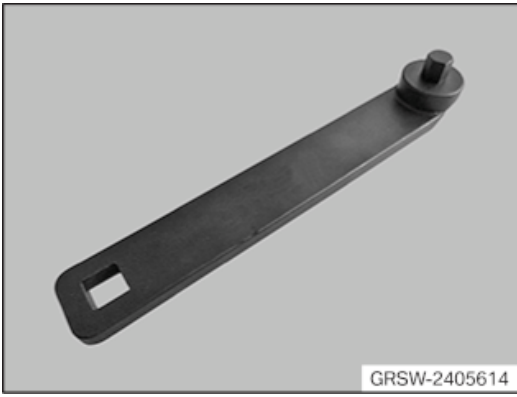

Storage location  
 Replaced by  
 In connection with  
 SI-Number 01 33 15 (305)

## Overview Technical Data

### Distance from window pane edge to wiper blade Used in step [103](#)

Wiper arm right (A)	87,3 mm
Wiper arm left (B)	67,2 mm

### Engine oil B47D20U1 / B47D20O1 / B47D20T1 Used in step [93](#)

Filling capacity, engine oil change with oil filter element	5,5 l
Engine oil: Technically suitable engine oils for BMW Group engines	

### GA8HP51Z transmission capacity Used in step [96](#)

	min. 9,28 l
Transmission oil: Automatic transmission fluid ATF 3+	

### GA8HP76Z transmission capacity Used in step [96](#)

	min. 9,35 l
Transmission oil: Automatic transmission fluid ATF 3+	

### Oil quantity between the two markings MIN and MAX of the oil dipstick Used in step [111](#)

1.0 l

# 24 00 039 Remove and install automatic transmission

## PRELIMINARY WORK

### 1 – Disconnecting all battery earth leads



- See additional information.

### 2 – Removing the acoustic cover

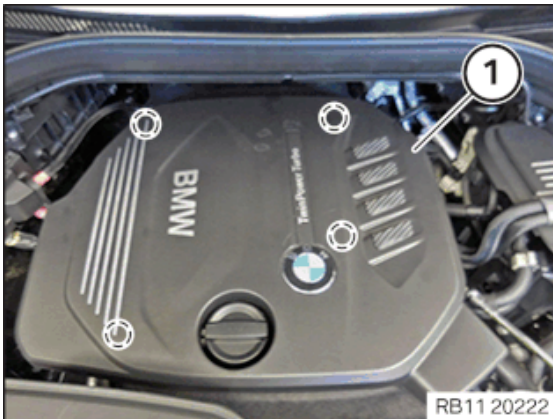

#### **Damage to the acoustic cover/design cover.**

**Jerky movements during disassembly and excessive application of force during installation may result in breakage of the acoustic cover/design cover.**

- Disassemble or mount the acoustic cover/design cover carefully.
  - Disassemble or mount snap-lock couplings of the ball pivots one after the other.
  - Disassemble or mount acoustic cover/design cover only at temperatures  $>20$  °C.
  - Use only distilled water as an auxiliary material during installation, no lubricants.
- Unclip the acoustic cover (1) from the marked areas towards the top.

### 3 – Remove resonator



**Hot surfaces.**

**Risk of burning!**

- Perform all work only on components that have cooled down.

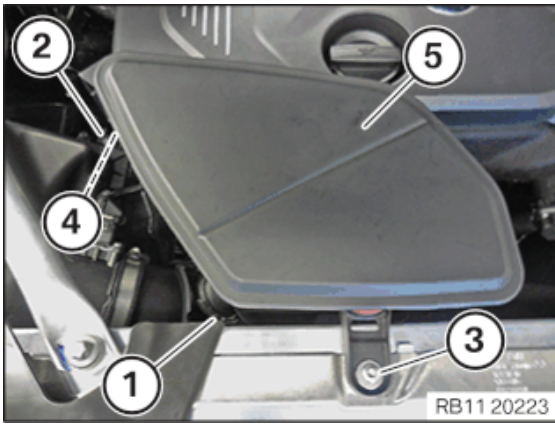

- Unfasten clamp (1).
- Loosen screw (2).
- Loosen screw (3).
- Loosen clamp (4).
- Guide out and remove the resonator (5).

#### 4 – Removing the front underbody protection

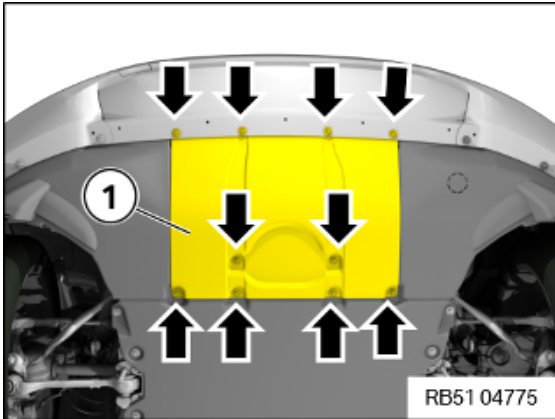

- Remove screws (arrows).
- Feed out the front underbody protection (1).

#### 5 – Remove acoustic cover of the front engine



**Hot surfaces.**

**Risk of burning!**

- Perform all work only on components that have cooled down.

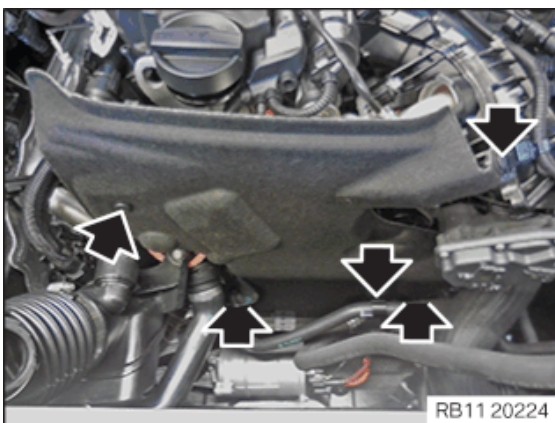

- Unlock and release the clamps (arrows).
- Guide the acoustic cover out and remove.

#### 6 – Removing the centre underbody protection

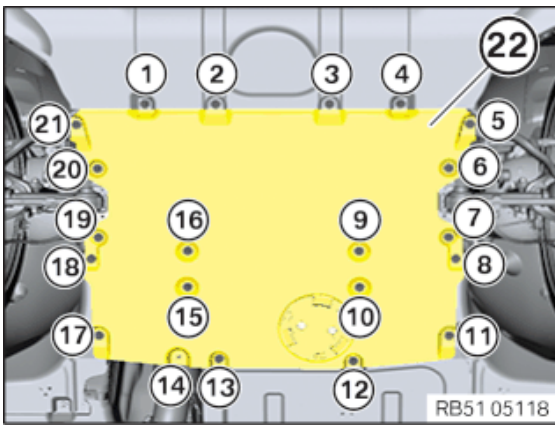

- Loosen screws (1) to (21).
- Guide out the centre underbody protection (22) at an angle toward the rear.

### 7 – Removing rear underbody protection

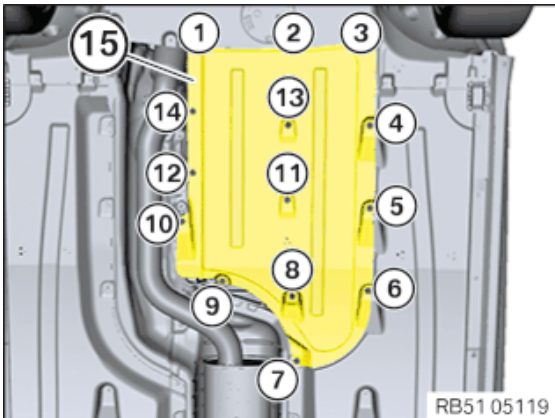

- Loosen screws (1) to (14).
- Guide out the rear underbody protection (15) at an angle toward the rear.

### 8 – If installed: Remove the underbody panelling of the transmission on the side

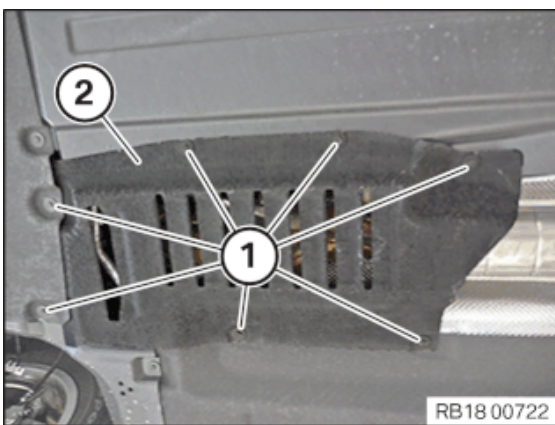

- Loosen screws (1).
- Remove the underbody panelling (2).

### 9 – Remove tank cover on left and right



The description is for one component only. The procedure is identical for all further components.

### ► Removing the tank cover

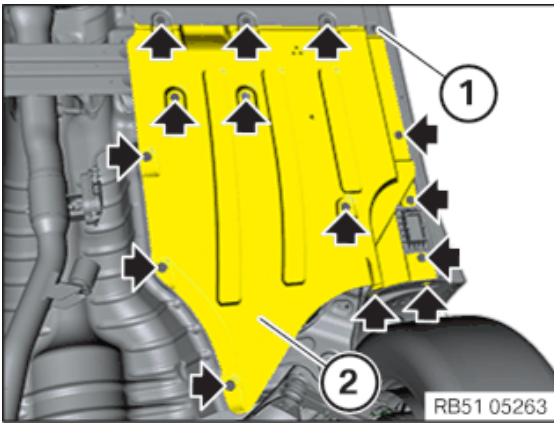

- Release the plastic nut (1).
- Release all bolts (arrows).
- Guide out and remove the tank cover (2) .

## 10 – Remove the connecting support from the tunnel

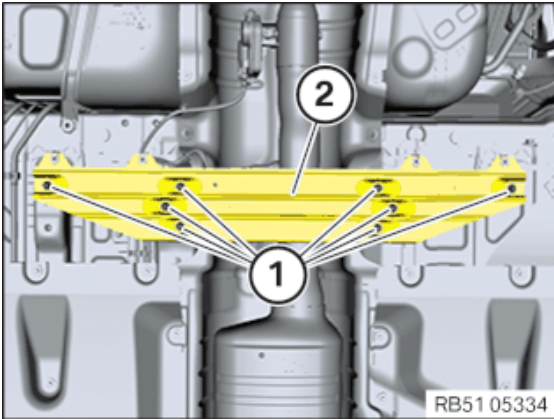

- Loosen screws (1).
- Remove the connecting support (2) at the tunnel.

## 11 – Remove exhaust system



**Hot surfaces.**

**Risk of burning!**

- Perform all work only on components that have cooled down.



**Component with heavy weight.**

**Danger of injury!**

- Note component's centre of gravity.
- Support component using a jack.
- Secure component against falling off the jack.



**Heavy component.**

**Heavy components can lead to injury or damage.**

- Remove and install heavy components with the aid of another person/other persons.

► If installed: Remove the right torsion strut



Driving without a torsion strut is not permitted.

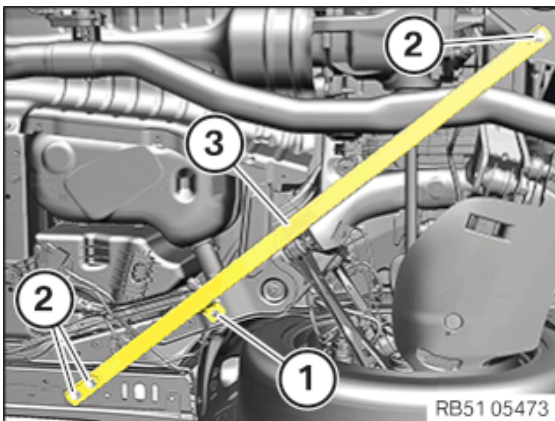

- Unfasten nut (1).
- Loosen screws (2).
- Thread out torsion strut (3) at right and remove.

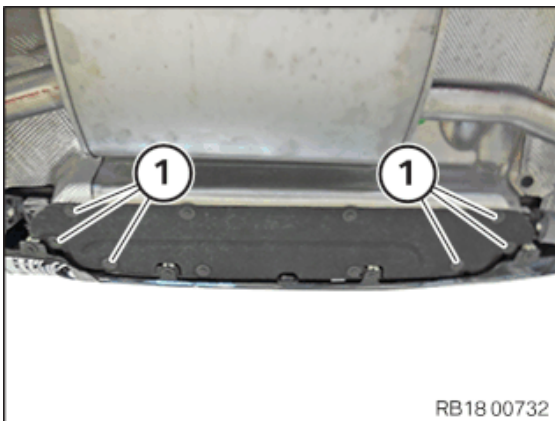

- Loosen screws (1).
- Partially detach the cover.

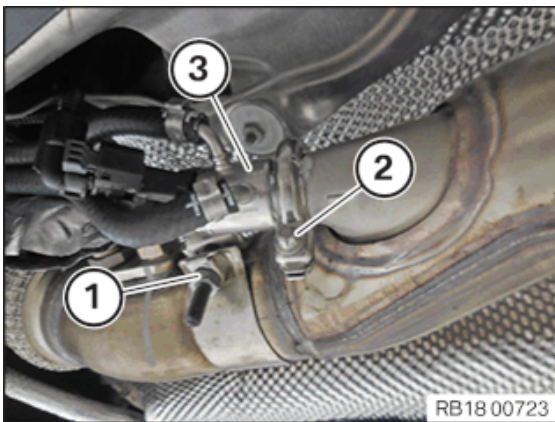

- Unfasten clamp (1).
- Detach the clamp (2) of the SCR metering module (3).
- Release the SCR metering module (3) from the exhaust system and set aside.

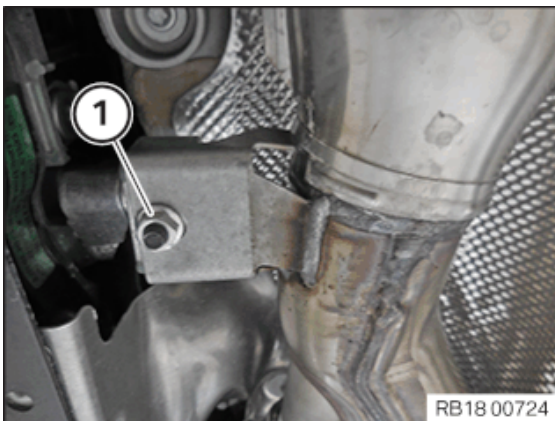

- Loosen nut (1).

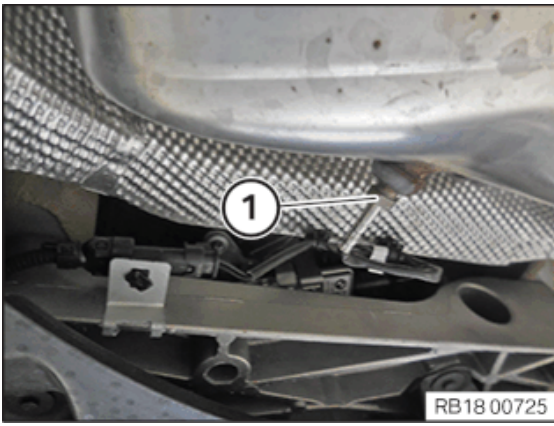

- Detach the exhaust temperature sensor (1) from the exhaust system.

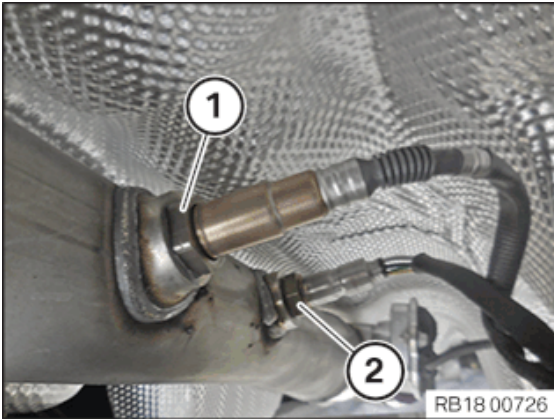

- Release the diesel particulate sensor (1)x from the exhaust system and set aside.
- Release the nitrogen oxide sensor (2) from the exhaust system and place to one side.

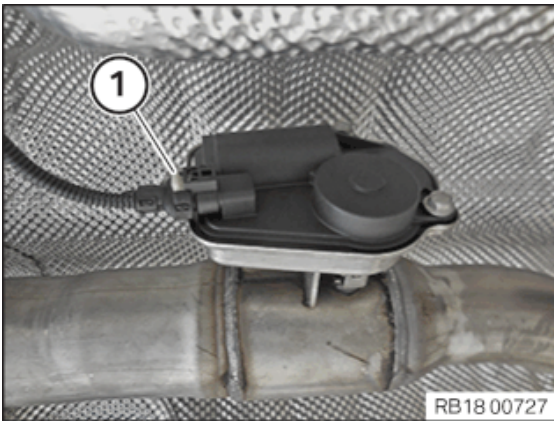

The following work step(s) is / are to be carried out if the specified component(s) is/are fitted.

- Unlock plug connection (1) and disconnect.

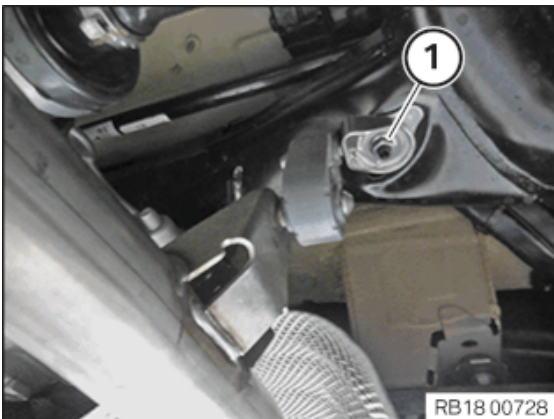

- Loosen nut (1).

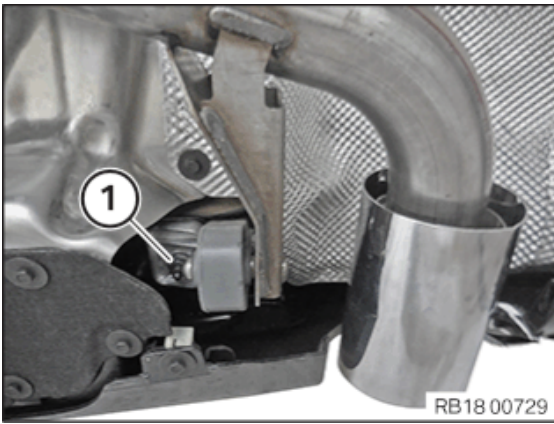

- Loosen nut (1).

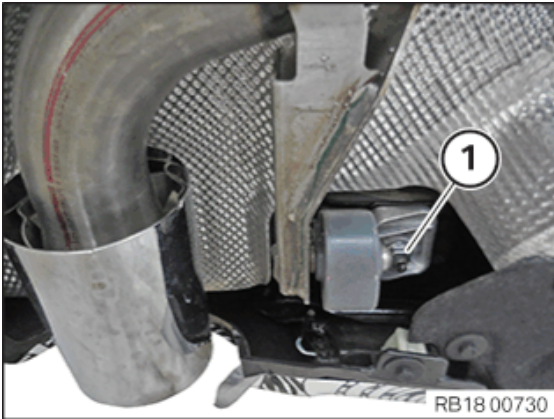

- Loosen nut (1).
- Lower the exhaust system with an auxiliary person, guide out and remove.

## 12 – Removing starter motor

### ► Removing the starter in vehicles with four-wheel drive

#### Prerequisite

Battery earth leads are disconnected.



**Hot surfaces.**

**Risk of burning!**

- Perform all work only on components that have cooled down.



**Working on 12 V vehicle electrical system.**

**Risk of short circuits! Risk of fire!**

- Make sure that **no charger** is connected to the jump start support point in the engine compartment.
- Detach battery earth lead from battery.
- With auxiliary batteries: Detach all battery earth leads from additional batteries.



Make sure that the acoustic cover is **not** damaged while removing the starter motor.  
A damaged lower acoustic cover can only be renewed when the front axle is lowered.

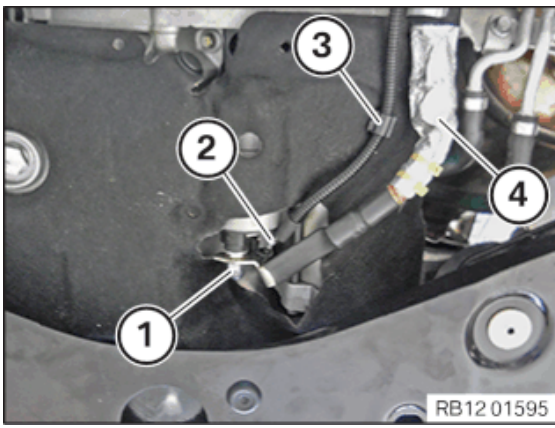

- **Version A:**

Unscrew the nut (1) and remove the positive battery cable from the starter motor.

Unscrew the nut (2) and disconnect the cable (terminal 50) from the starter motor.

Release the clamp (3) and put the cable to one side.

Release the positive battery cable from the clamp (4) and set aside.

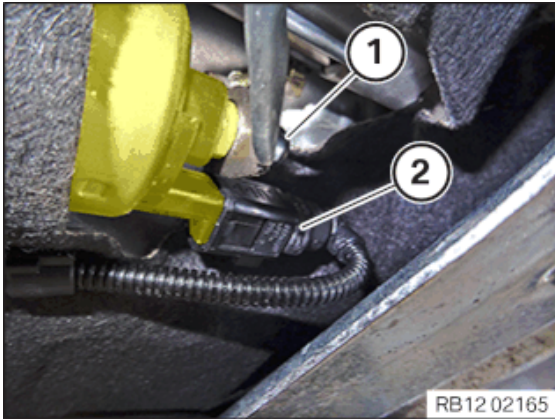

- **Version B:**

Loosen nut (1).

Unlock plug connection (2) and disconnect.

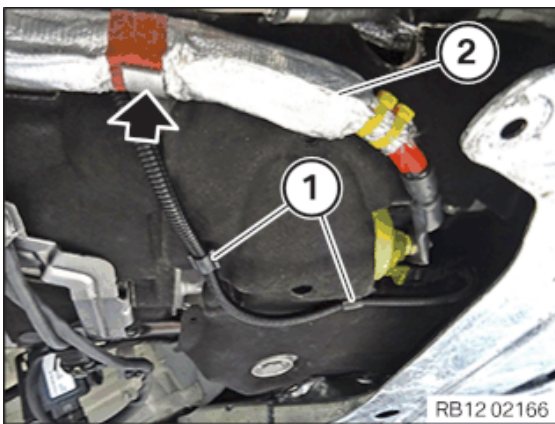

- Loosen clamps (1).

- Feed the positive battery cable (2) out of holder (Arrow) and place aside.

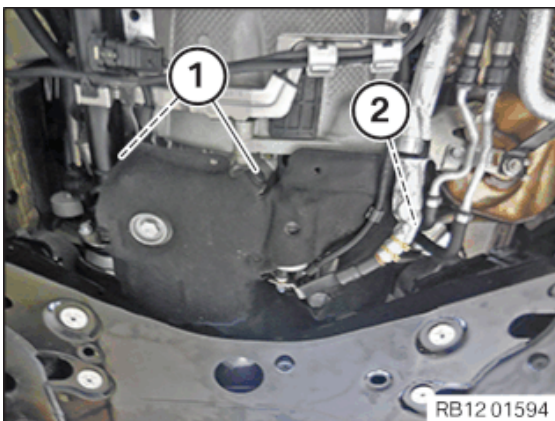

- Release the rear expanding rivet (1) from the acoustic cover.

- Loosen clip (2).

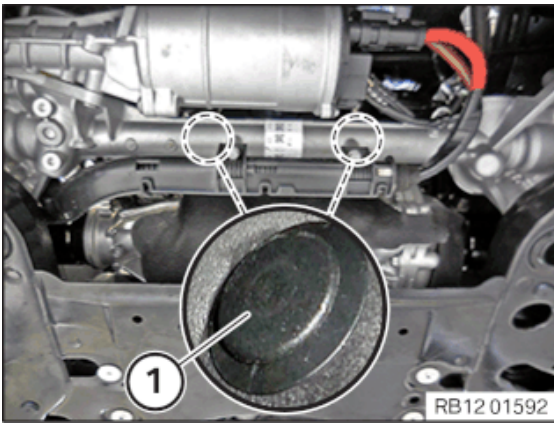

- Release the front expanding rivet (1) from the acoustic cover.

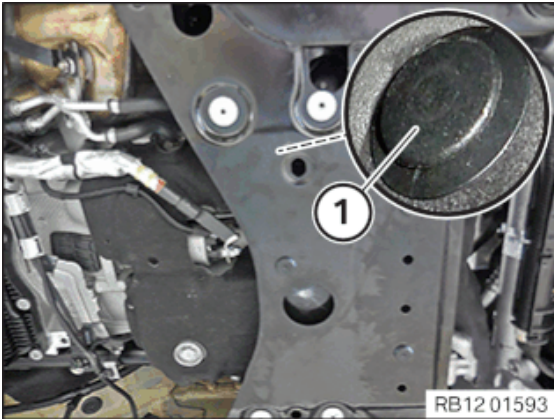

- Release the centre expanding rivet (1) from the acoustic cover.

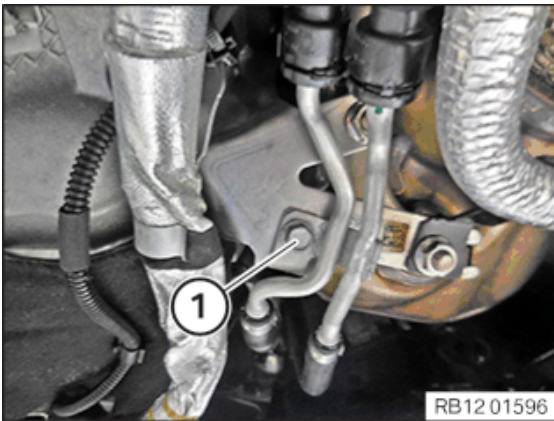

- Loosen screw (1).

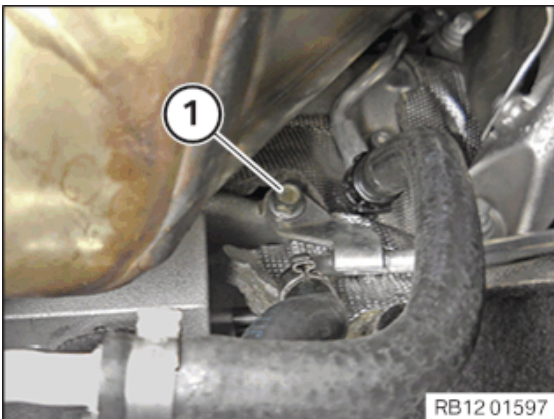

- Release the screw (1) and put the coolant lines to one side.

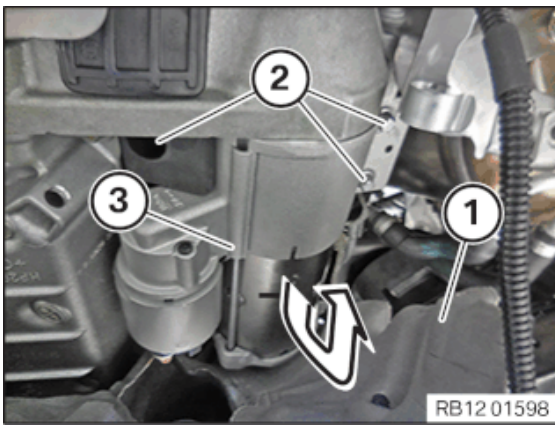

- Make sure that the acoustic cover (1) is not damaged.
- Carefully press the acoustic cover (1) to one side.
- Loosen screws (2).
- Carefully guide out the starter motor (3) in direction of arrow and remove.

### ► Removing the starter motor on vehicles with rear-wheel drive

#### Prerequisite

Battery earth leads are disconnected.



**Hot surfaces.**

**Risk of burning!**

- Perform all work only on components that have cooled down.



**Working on 12 V vehicle electrical system.**

**Risk of short circuits! Risk of fire!**

- Make sure that **no charger** is connected to the jump start support point in the engine compartment.
- Detach battery earth lead from battery.
- With auxiliary batteries: Detach all battery earth leads from additional batteries.



Make sure that the acoustic cover is **not** damaged while removing the starter motor.

A damaged lower acoustic cover can only be renewed when the front axle is lowered.

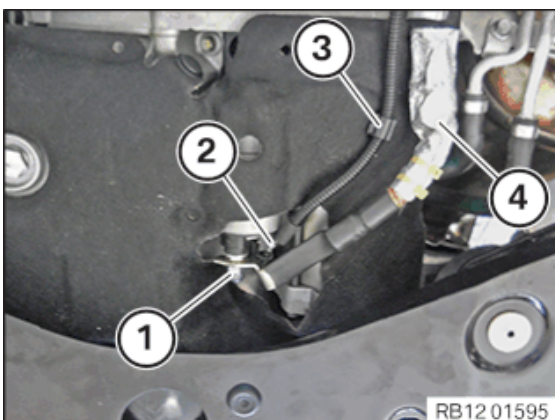

#### • Version A:

Unscrew the nut (1) and remove the positive battery cable from the starter motor.

Unscrew the nut (2) and disconnect the cable (terminal 50) from the starter motor.

Release the clamp (3) and put the cable to one side.

Release the positive battery cable from the clamp (4) and set it aside.

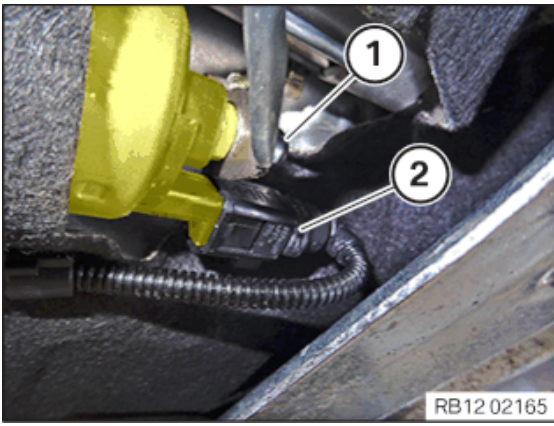

- **Version B:**  
Loosen nut (1).  
Unlock plug connection (2) and disconnect.

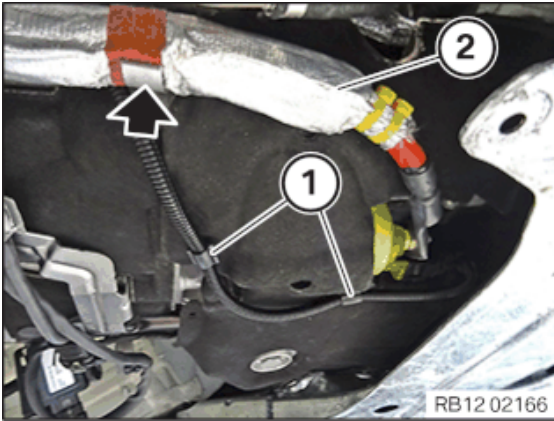

- Loosen clamps (1).
- Feed the positive battery cable (2) out of holder (Arrow) and place aside.

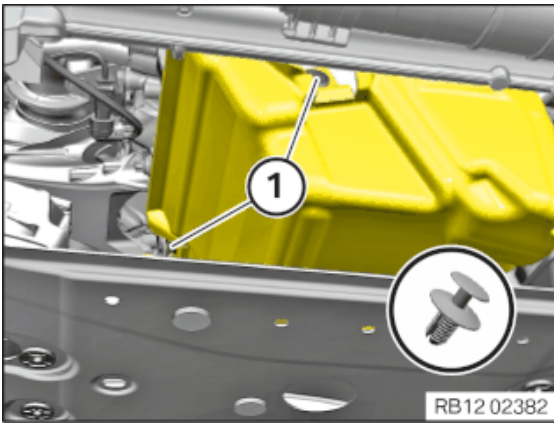

- Release the expanding rivet (1).

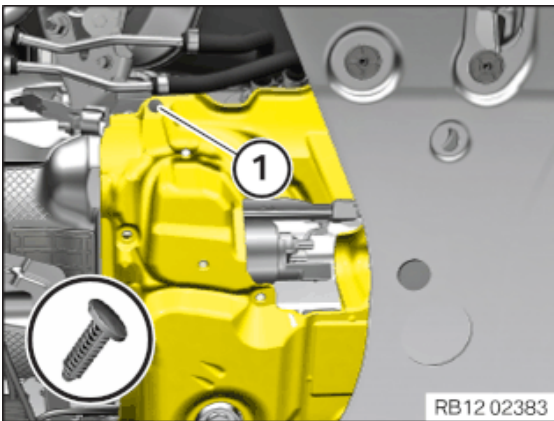

- Undo Christmas tree clip (1).

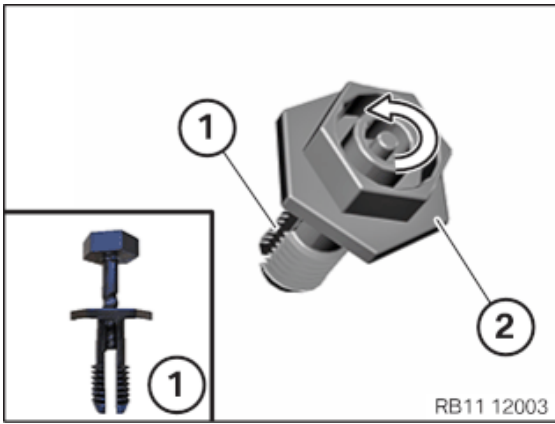

- Hold down expanding rivet (1) on the left side in area (2) and release it by turning it in the direction of the arrow.

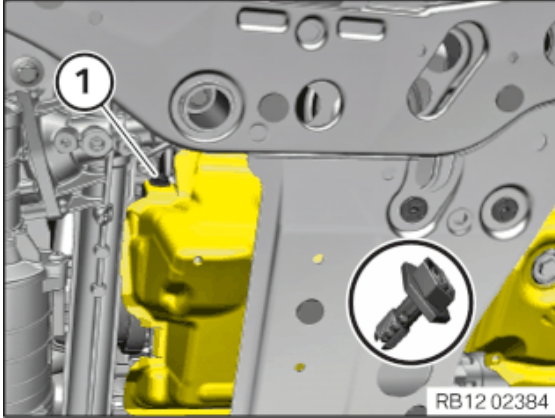

- Release expanding rivet (1).

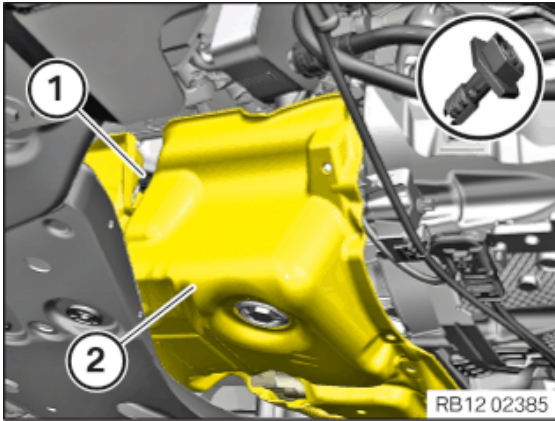

- Loosen expanding rivet (1).
- Feed out the oil sump acoustic cover (2) and place aside.

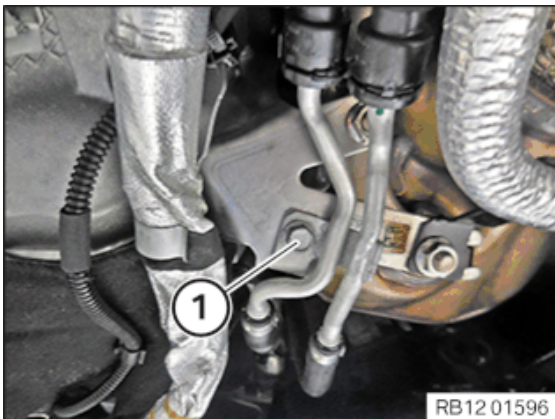

- Loosen screw (1).

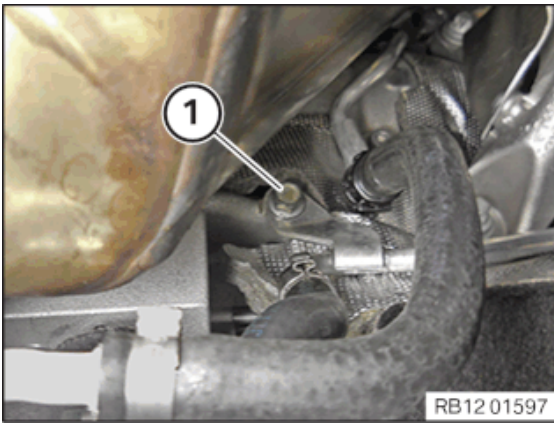

- Release the screw (1) and put the coolant lines to one side.

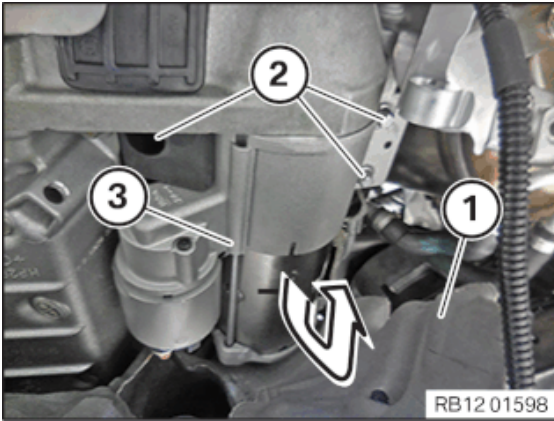

- Make sure that the acoustic cover (1) is not damaged.
- Carefully press the acoustic cover (1) to one side.
- Loosen screws (2).
- Carefully guide out the starter motor (3) in direction of arrow and remove.

### 13 – Remove the heat shield

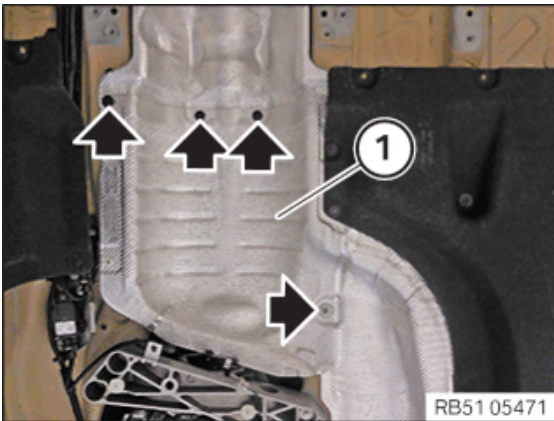

- Loosen bolts and nuts (arrows).
- Remove the heat shield (1).

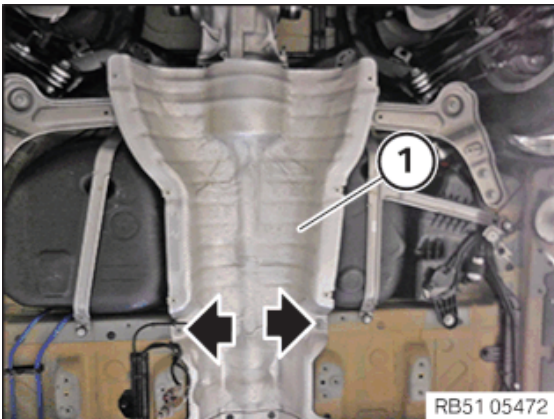

- Loosen bolts and nuts (arrows).
- Remove the heat shield (1).

### 14 – Remove the retaining plates

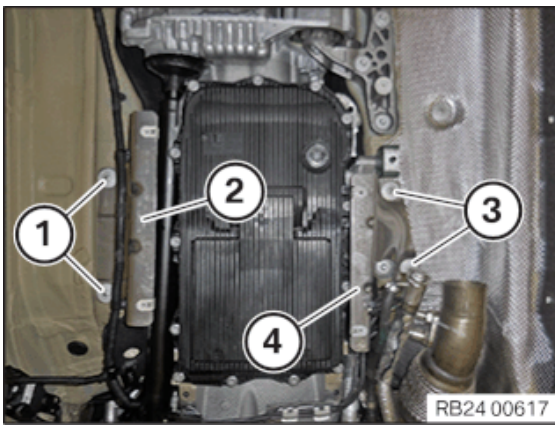

- Loosen nuts (1) and (3).
- Remove retaining plates (2) and (4).

## 15 – Partially releasing propeller shaft



### Damage to propeller shaft during removal.

**Non-observance of the removal guidelines for the propeller shaft on the rear axle differential may cause severe damage.**

- Do not disassemble the three-hole flange, flexible disc and propeller shaft. The three-hole flange to the rear axle differential is balanced with the flexible disc and propeller shaft.
- Loosen the recessed nut against the direction of travel in clockwise direction. The propeller shaft must be loosened on the recessed nut only and exclusively in the direction of rotation otherwise the anti-twist lock of the bi-hexagonal flange nut is damaged.
- In the event of a damaged anti-twist lock on the bi-hexagonal flange nut: Replace the rear axle differential.

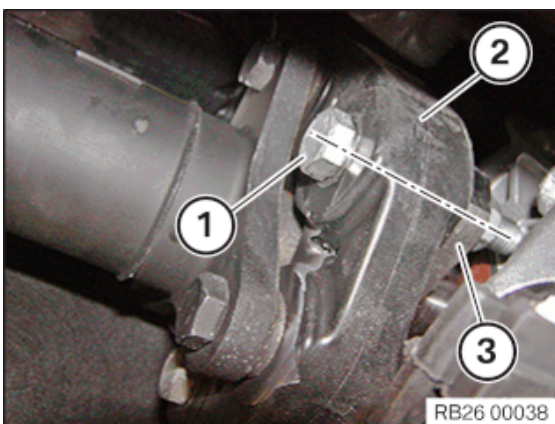

- Mark installation position of screw connection (1) of flexible disc (2) and of three-hole flange (3).

The mark makes it possible for the propeller shaft to be installed again in the same position. This should prevent a humming noise from the drive train during driving.

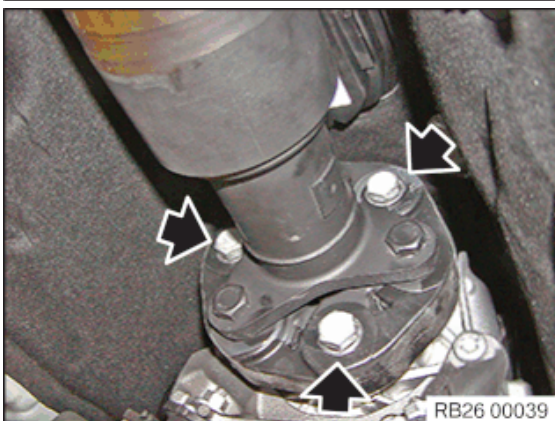

- Remove screws (arrows).

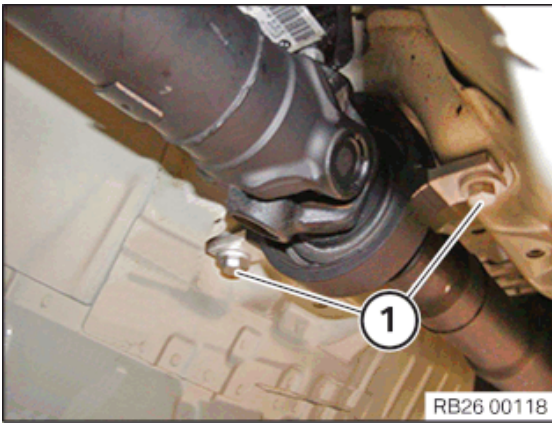

- Unscrew the bolts (1) on the centre mount and hold down the propeller shaft.  
Major deflection angles of the propeller shaft may damage the propeller shaft and/or the joints.
- Tie up propeller shaft to underbody.

## MAIN WORK

---

### 16 – Remove automatic transmission (GA8HP51Z)



**Materials harmful to health.**

**Contact with fluids harmful to health!**

- Note and follow safety information on containers.
- Conduct all work in appropriate personal protective equipment only.



**Damage to the engine block.**

**Serious damage to the engine block and transmission due to damaged and corroded bolts.**

- It is imperative that protruding threads of the transmission bolts are checked for corrosion and damage prior to removal.
- It is imperative that all rust is removed from corroded threads and that they are cleaned prior to removal.
- Renew rusted and damaged bolts.



**Damage of components in the engine compartment.**

**When removing the transmission, tilting of the engine may damage components in the engine compartment.**

- Before removing the transmission: Support engine.
- Secure the engine against tilt movements.
- Follow the specifications of the repair instructions.



**Damage to the transmission.**

**Damage to the transmission by unapproved transmission oil.**

- Use only the approved transmission oil.
- Check the transmission oil level after completing the repair.

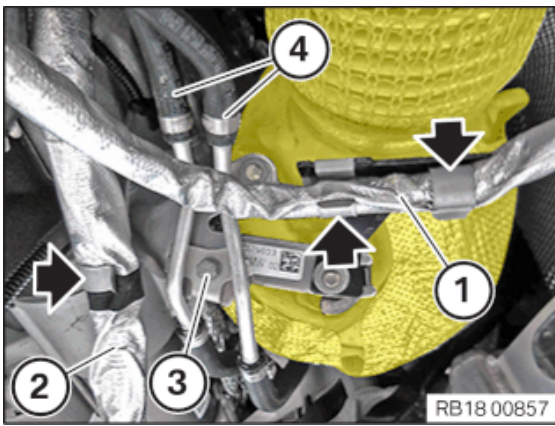

- Release the metering line (1) from clamps (Arrows).
- Release positive battery cable (2) from starter motor from clamp (Arrow).
- Loosen screws (3).
- Thread off coolant line (4) and place to the side.

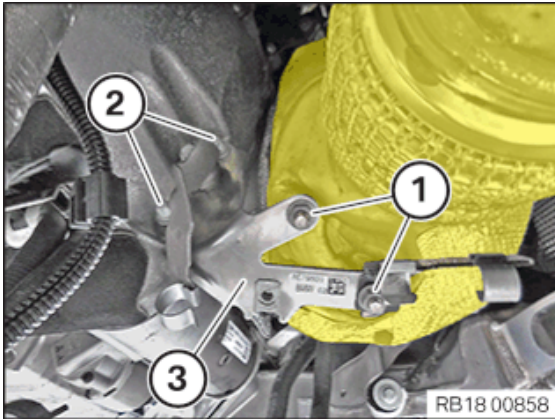

- Loosen nuts (1).
- Loosen screws (2).
- Guide out and remove holder (3).

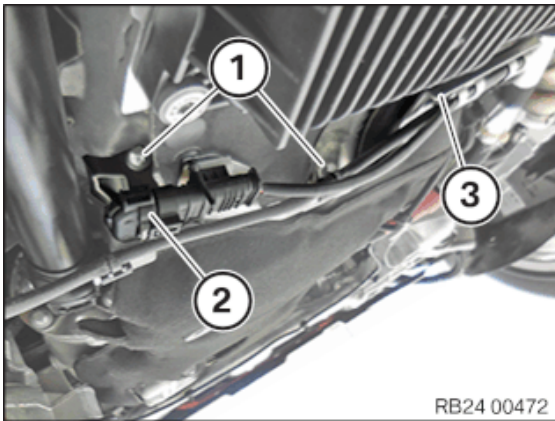

- Loosen screws (1).
- Disconnect the connector (2).
- Remove holder (3).

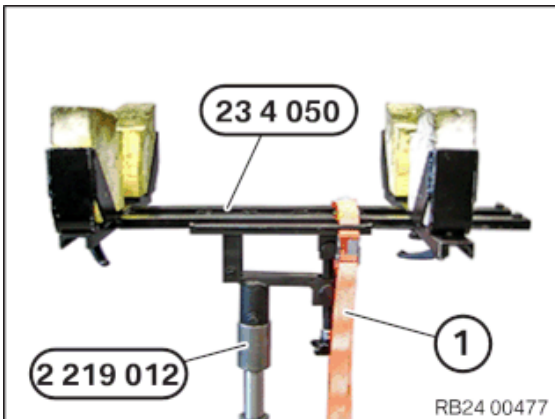

- Support the transmission using special tools **2 219 012** and **0 495 498 (23 4 050)**.
- Secure the transmission with the tensing strap (1).

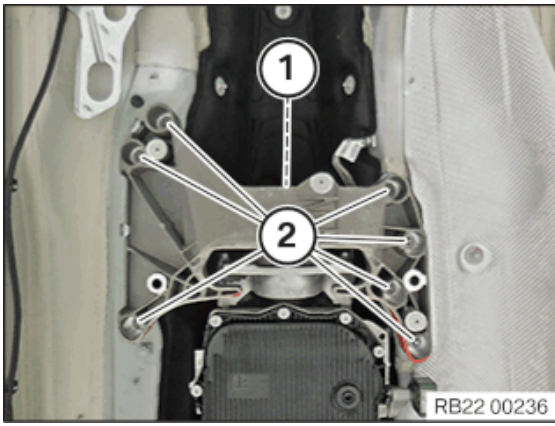

- Loosen screw (1).
- Loosen screws (2).
- Remove transmission cross member.

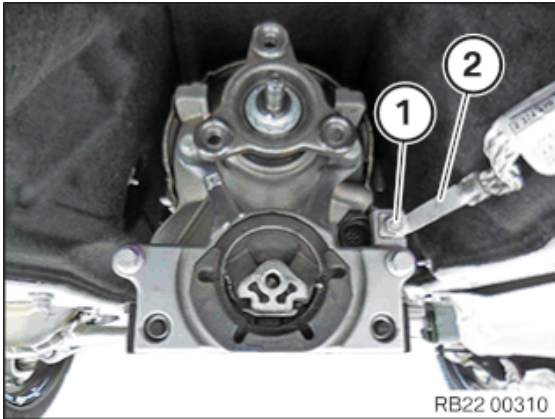

- Unscrew the bolt (1) and disconnect the ground strap (2).

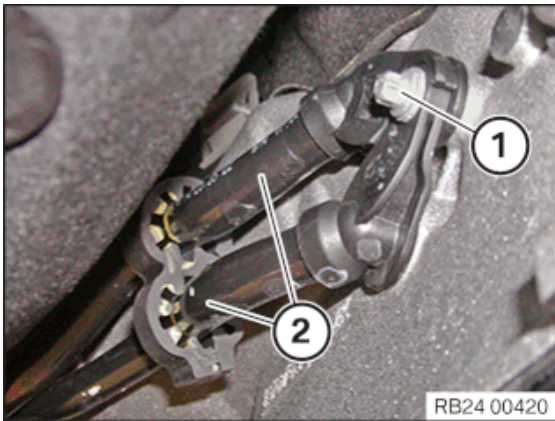

- Loosen screw (1).
- Disconnect hydraulic lines (2) to transmission oil cooler.

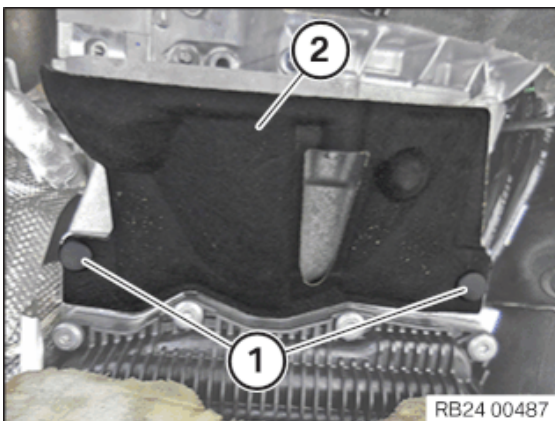

- Pull the expanding rivet (1) off.
- Remove the acoustic cover (2).

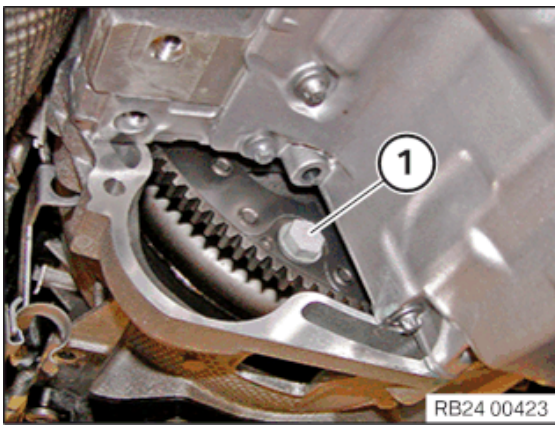

**Only G05 and G07**

In vehicles with active anti-roll bar (ARS) the fan cowl must be removed in order to spin the engine.

For additional information see: 17 11 035 Removing and installing/replacing the fan cowl including electric fan

- Turn the engine on the vibration damper with the special tool **0 493 380 (11 6 480)** in the direction of rotation until the bolt (1) becomes visible in the recess.
- Undo all 6 screws (1) on the torque converter.
- Prepare special tool **0 494 478 (24 4 161)** (1) with the shaped element **0 494 965 (24 4 165)** (2) as shown.

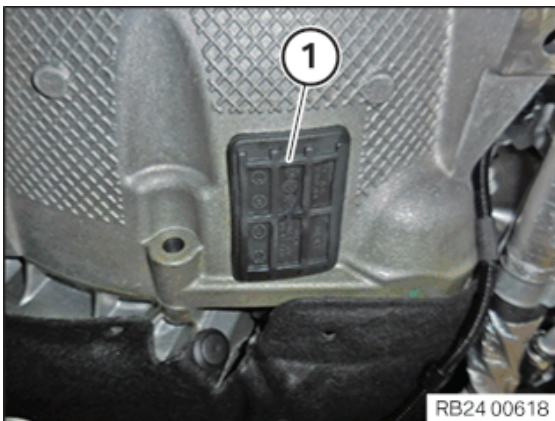
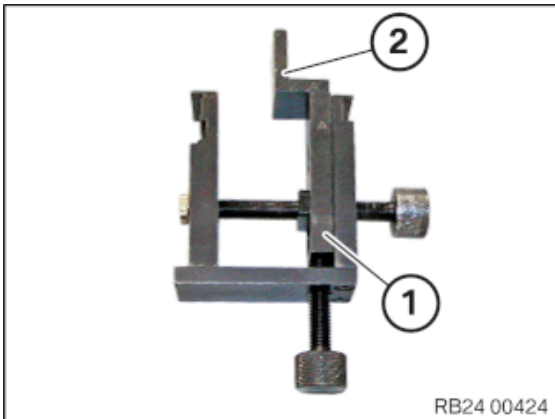

- Remove the sealing cap (1).

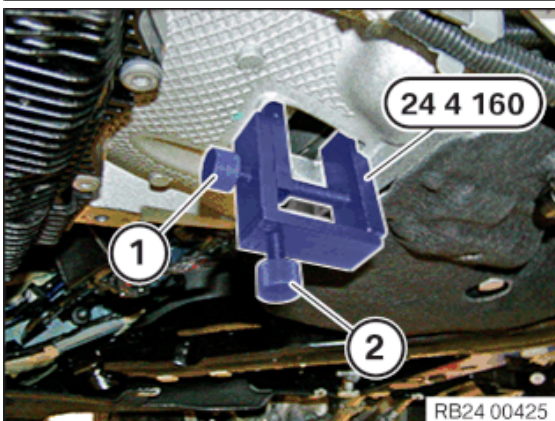

- Insert special tool **0 494 451 (24 4 160)** into the recess of the transmission housing and apply slight tension using the screw (1).
- Screw the bolt (2) in to the stop.
- Tighten down screw (1).

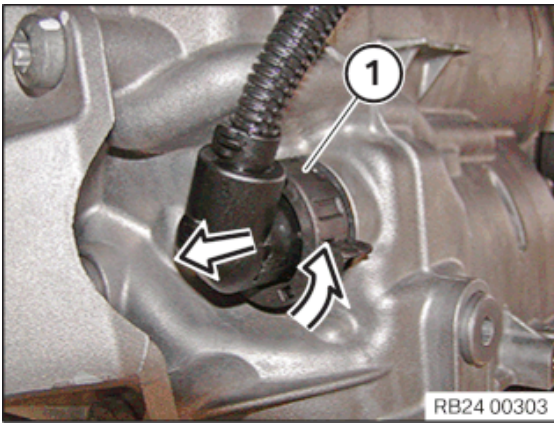

**i**

Notes on mechatronics are a fundamental requirement for these repair instructions and must be complied with at all times.

For additional information see: 24 34 ... Notes on mechatronics

(GA8HP50Z/GA8HP51Z/GA8HP75Z/GA8HP76Z/GA8HP95Z)

- Unlock connector (1) by turning and pull off.
- Do not touch pins.
- Loosen all cable clips.
- Insert the special tool **0 494 213 (24 2 390)** into the sealing sleeve (1).

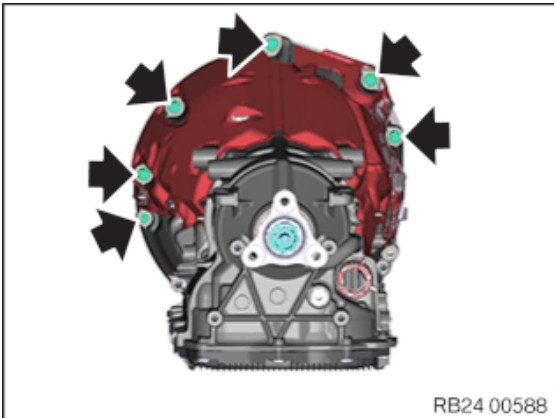
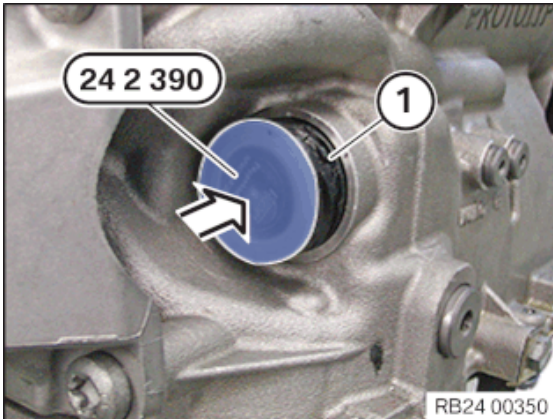

- Support engine.
- Unscrew the remaining 6 transmission bolts (arrows) and remove the transmission.

## 17 – Install automatic transmission (GA8HP51Z)



**Damage to the transmission.**

**Damage to the transmission by unapproved transmission oil.**

- Use only the approved transmission oil.
- Check the transmission oil level after completing the repair.

**i**

After completion of the work, program the control unit for the electronic transmission control (EGS).

► **Checking mounting orientation of torque converter**

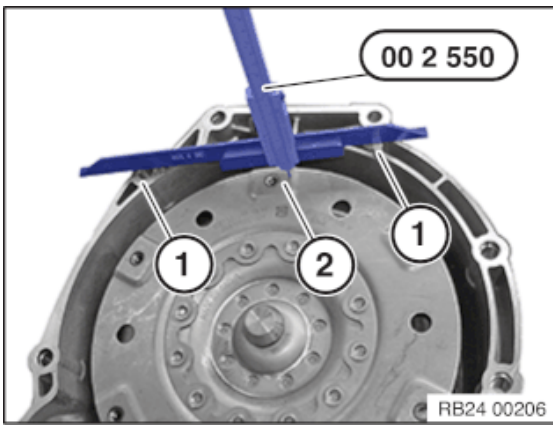

**Damage to the automatic transmission/impeller.**

**When disconnecting the engine and transmission, the torque converter can become loose! Failure to observe the correct installation positions of the torque converter may lead to damage to the impeller driver.**

- Make sure that the torque converter is in the correct installation position before installing the automatic transmission.

- Check the installation dimension between the contact surfaces (1) and the outer edge (2) of the torque converter threaded hole using special tool **0 490 189 (00 2 550)**.

See repair instructions

Remove and install/replace torque converter ()

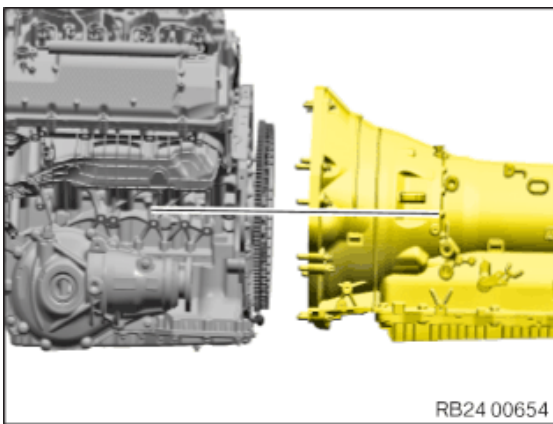

**Damage to flywheel and automatic transmission.**

**If the automatic transmission is not fitted horizontally while removing and installing it, then this can cause damage to the automatic transmission or the flywheel.**

- While removing and installing, align the automatic transmission fully horizontal to the engine.
- Check for a correct alignment before tightening the transmission bolts.

- Align the automatic transmission horizontal to the engine before installation.

- Check the fitting sleeves (1) for correct fit and damage and renew as needed.

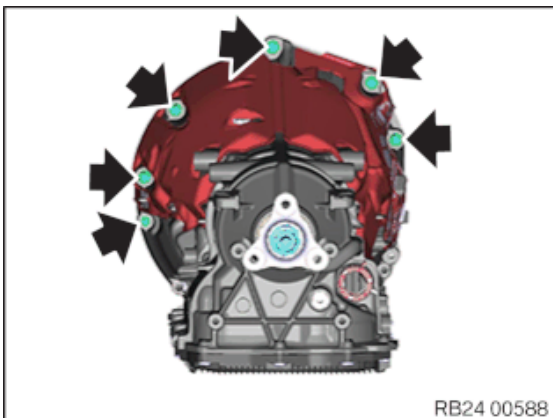
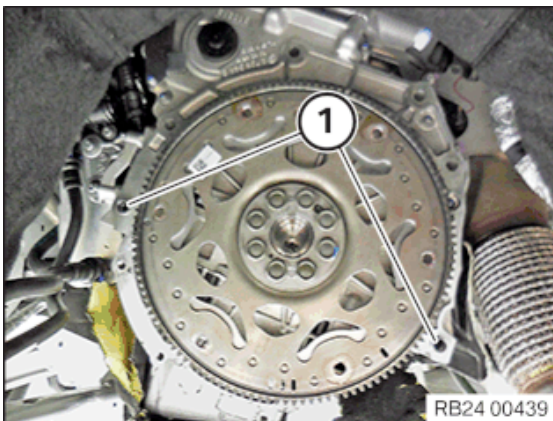

- Transmission flange-mount.
- Rotate torque converter until bore hole in torque converter is flush with bore hole in drive plate.
- Fit the transmission bolts (arrows) and apply hand-tight.

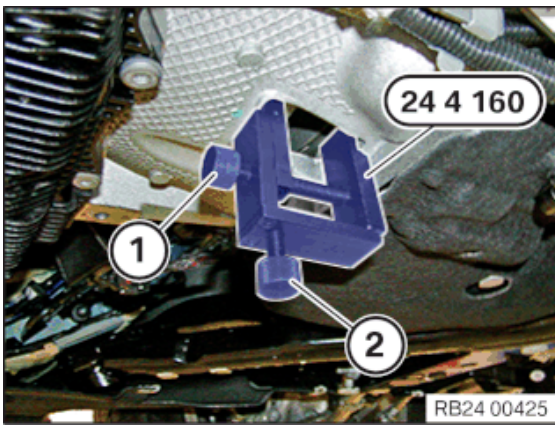

- Release screw (1) and screw (2).
- Remove special tool **0 494 451 (24 4 160)**.

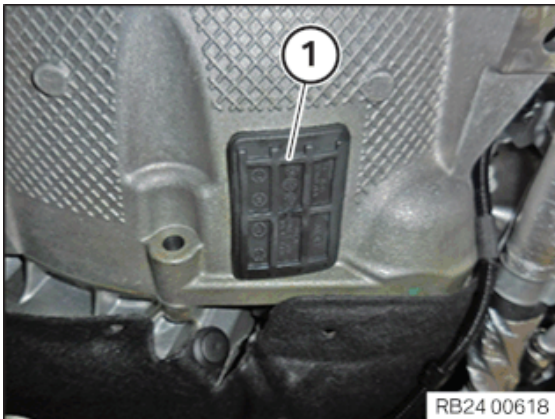

- Install the sealing cap (1).

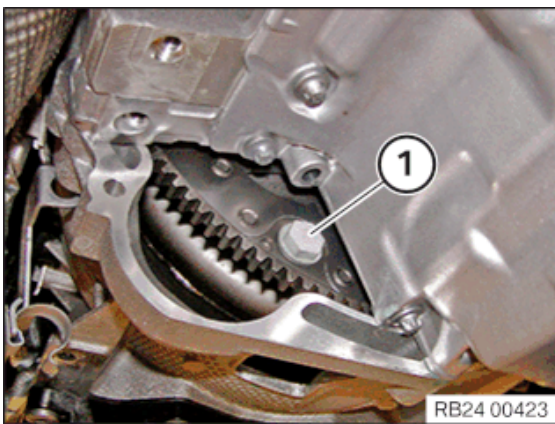

#### Only G05 and G07

In vehicles with active anti-roll bar (ARS) the fan cowl must be removed in order to spin the engine.

For additional information see: 17 11 035 Removing and installing/replacing the fan cowl including electric fan

- Renew screws.
- **Parts:** Screws
- Crank the engine on the vibration damper in the direction of rotation using special tool **0 493 380 (11 6 480)** to tighten all six screws (1).
- Tighten all 6 screws (1) of the torque converter using special tool **0 491 667 (24 1 110)**.

#### Torque converter to flywheel

M10	Renew screws.	Tightening torque	56 Nm
-----	---------------	-------------------	-------

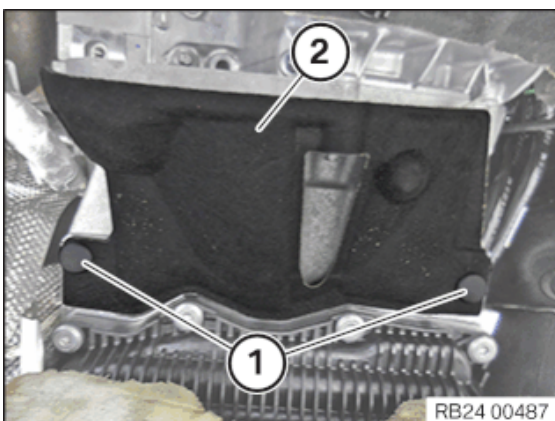

- Install acoustic cover (2).
- Install expanding rivet (1).

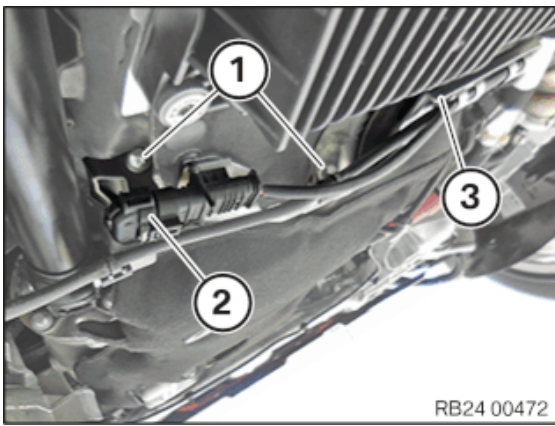

- Install holder (3).
- Connect connector (2).
- Insert screws (1) and tighten lightly.

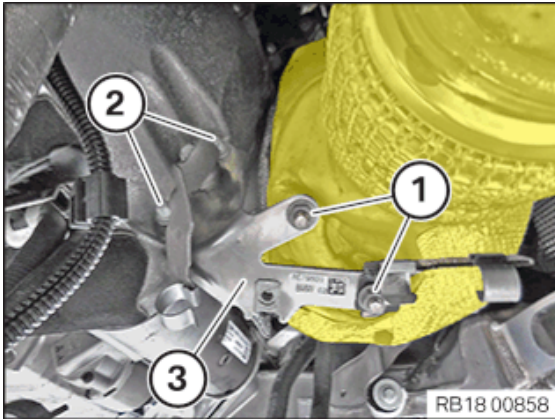

- Insert and install the holder (3).
- Tighten the screws (2) from the bracket (3).

**Bracket to transmission for diesel particulate filter holder bottom**

M8X20	Tightening torque	19 Nm
-------	-------------------	-------

- Tighten the nuts (1) on the holder (3).

**Lower holder to diesel particulate filter**

M8	Tightening torque	19 Nm
----	-------------------	-------

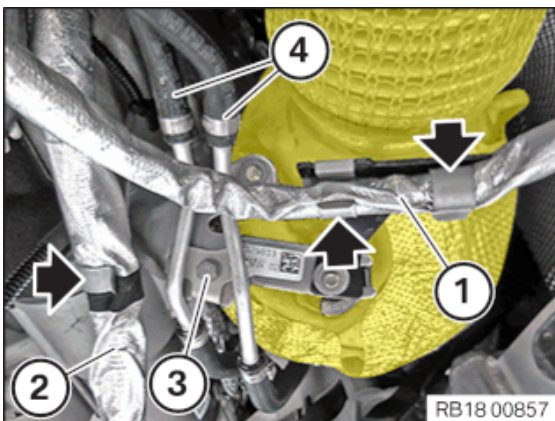

- Thread in and install coolant line (4).
- Tighten down screw (3).

**Coolant line to crankcase/diesel particulate filter**

M6x16	8 Nm
-------	------

- Secure the positive battery cable (2) of the starter motor at the clamp (arrow).
- Fasten the metering line (1) on the clamps (arrows).

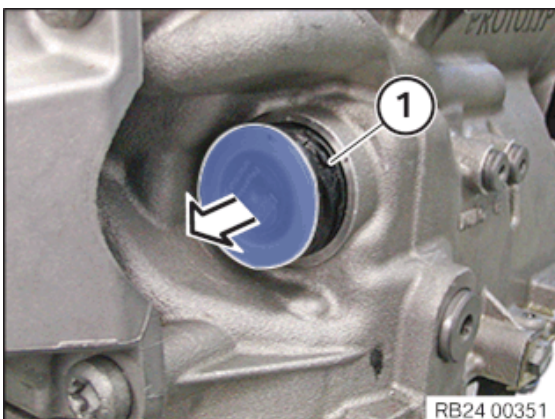

- Remove the special tool **0 494 213 (24 2 390)** from the sealing sleeve in direction of arrow.

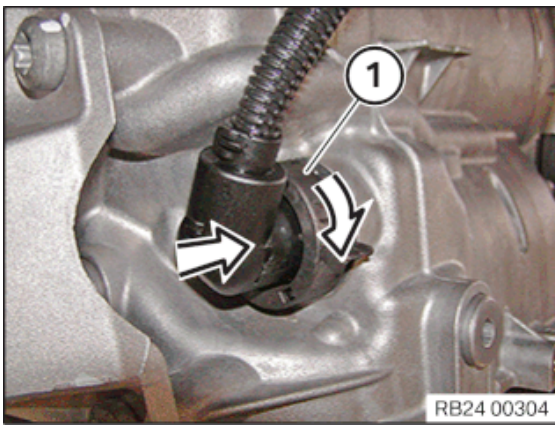

Notes on mechatronics are a fundamental requirement for these repair instructions and must be complied with at all times.

For additional information see: 24 34 ... Notes on mechatronics

(GA8HP50Z/GA8HP51Z/GA8HP75Z/GA8HP76Z/GA8HP95Z)

- Slide the connector (1) on and turn it to lock.
- Tighten the transmission bolts in sequence (1) to (9).

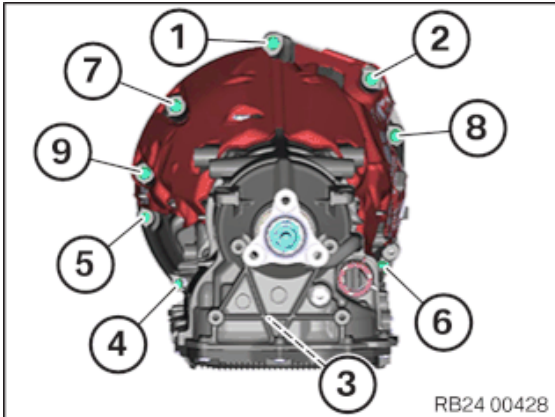

#### Transmission to engine

M8	Tightening torque	19 Nm
M12	Tightening torque	66 Nm

- Renew sealing rings.  
**Parts:** Sealing ring
- Install hydraulic lines (2) on transmission.
- Position and tighten the screw (1).

#### Transmission oil line to transmission

M6x25	Renew the sealing ring.	Tightening torque	8 Nm
-------	-------------------------	-------------------	------

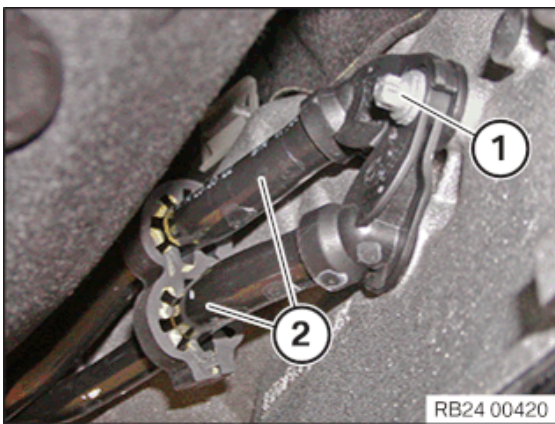

- Install the ground strap (2).
- Tighten down screw (1).

#### Ground strap to transmission or body

M8	Tightening torque	19 Nm
----	-------------------	-------

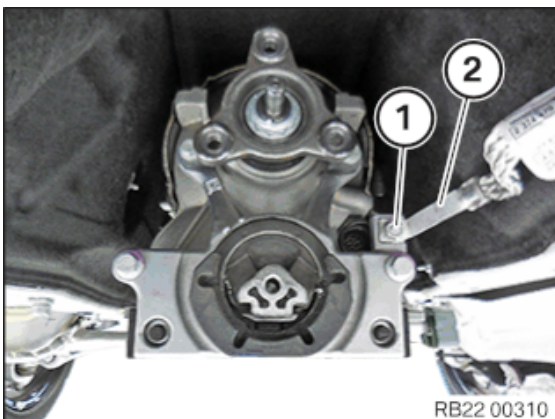

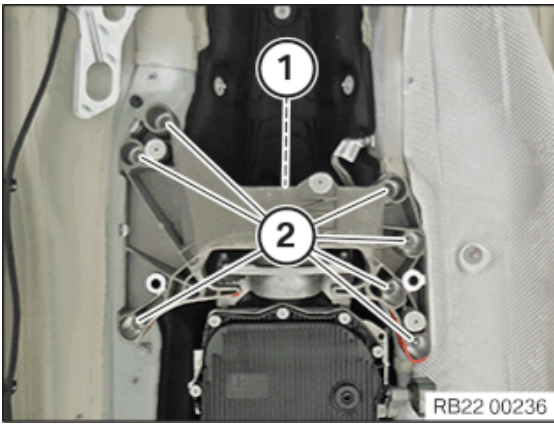

- Install transmission cross-member.
- Renew the screw (1).  
**Parts:** Screw
- Tighten down screw (1).

**Transmission cross member to rubber mounts**

M12	Tightening torque	100 Nm
-----	-------------------	--------

- Renew screws(2).
- Parts:** Screws
- Tighten the screws (2).

**Transmission cross member to body**

M8	Tightening torque	19 Nm
----	-------------------	-------

- Remove the transmission jack.

**POSTPROCESSES**

**18 – Securing propeller shaft (partially removed)**

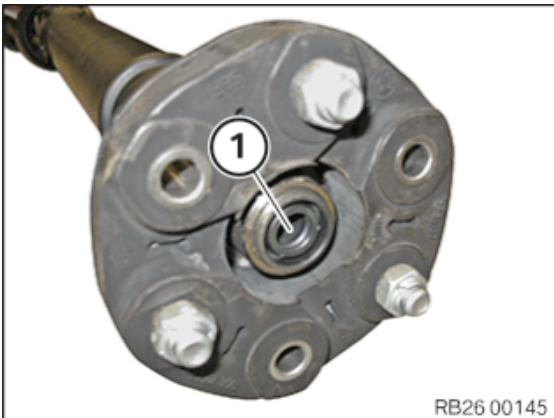

- Check centring (1) for damage; renew if necessary.

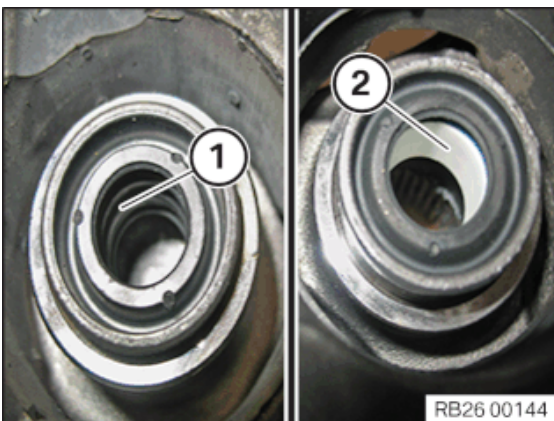

- Apply a thin coat of grease to the soft centring (1), if necessary.  
Do not grease the hard centring (2).

**Expendable materials**

Lubricating grease Olistamoly 2 LN 584 LO	100 g, Tube	83 19 0 447 919
---	----------------	-----------------

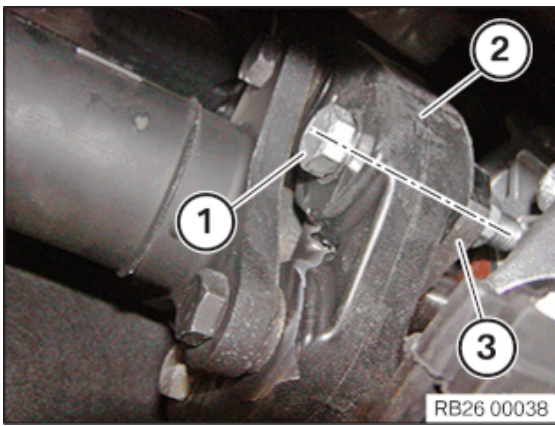

- Renew screws and the self-locking nuts.

**Parts:** Screws, self-locking nuts

- Assemble the screw connections (1) of the flexible disc (2) and the three-hole flange (3) according to the self-affixed identification.

This should prevent a humming noise from the drive train during driving.

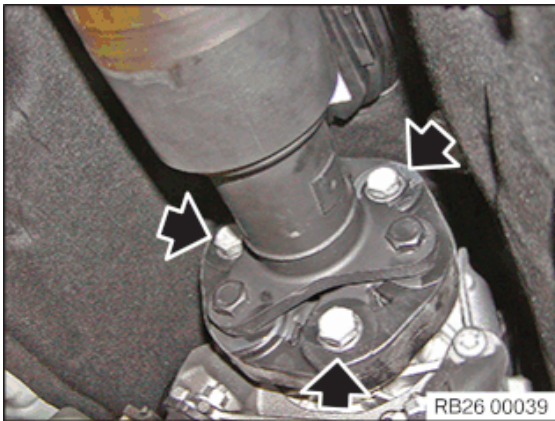

- Hand-tighten the screws and nuts (arrows), but do not tighten fully.

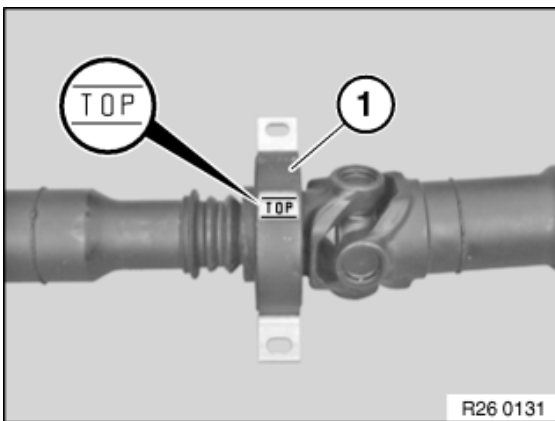

- Install the centre mount (1) with the designation **TOP** at the top in the transmission tunnel.

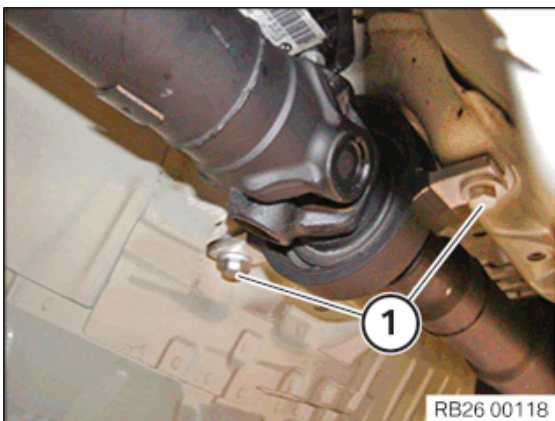

- Position centre mount.
- Hand-tighten the bolts (1), but do not tighten fully.

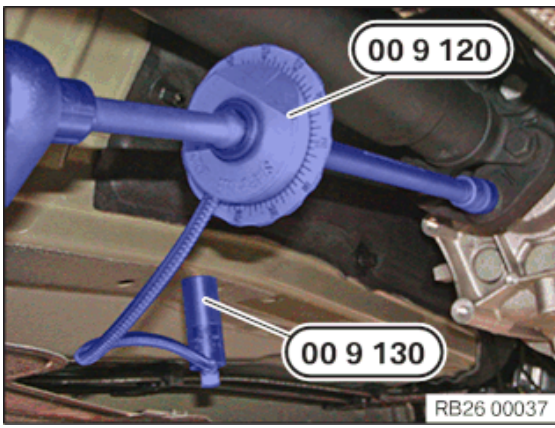

- Renew screws.

**Parts:** Screws

- Provide counter support for the bolts of the flexible disc on the nut and tighten with the bolts.

#### Front flexible disc to propeller shaft

M12	Renew screws. Comply with jointing torque and angle of rotation. Tightening via screw.	Jointing torque	55 Nm
		Angle of rotation	90 °

- Secure the special tool **0 490 504 (00 9 120)** with the special tool on the vehicle underbody and continue to screw it in according to the angle of rotation.

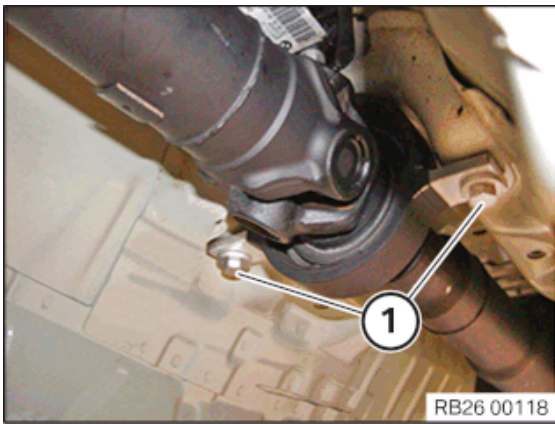

- Tighten the screws (1).

#### Centre mount to body

M8		Tightening torque	19 Nm
----	--	-------------------	-------

### 19 – Install the retaining plates

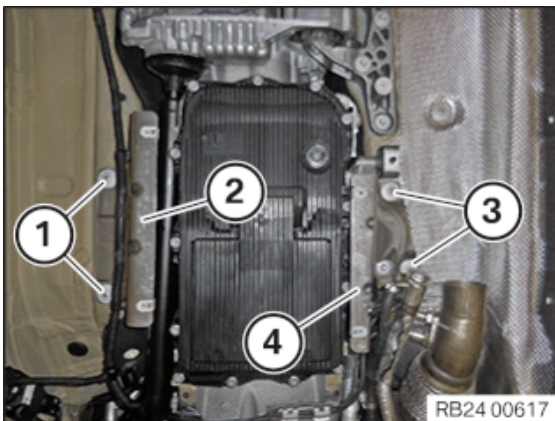

- Install the retaining plates (2) and (4).
  - Renew the nuts (1) and (3).
- Parts:** Nuts
- Tighten nuts (1) and (3).

#### Retaining plates for vehicle underbody cover

Sheet metal nut/plastic nut	Renew nuts.	Tightening torque	3 Nm
-----------------------------	-------------	-------------------	------

### 20 – Installing the heat shields

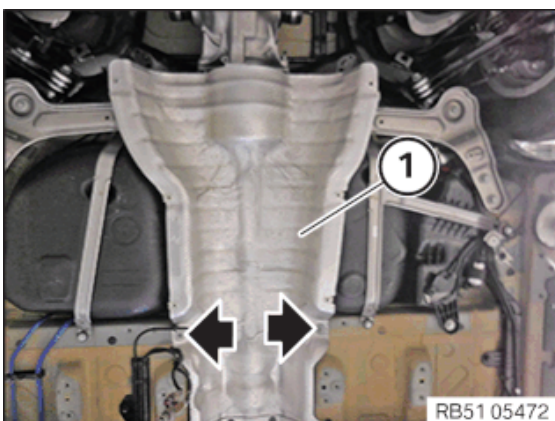

- Install heat shield (1).
- Tighten the nuts and bolts (arrows).

#### Heat shield to undercarriage

Screws and nuts		Tightening torque	3 Nm
-----------------	--	-------------------	------

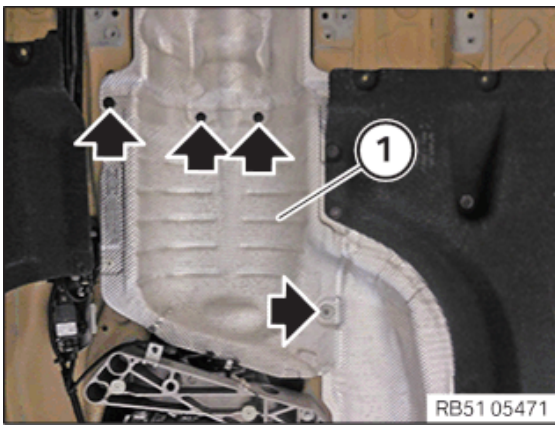

- Install heat shield (1).
- Tighten the nuts and bolts (arrows).

#### Heat shield to undercarriage

Screws and nuts	Tightening torque	3 Nm
-----------------	-------------------	------

## 21 – Installing starter motor

### ► Installing the starter motor on vehicles with all-wheel drive

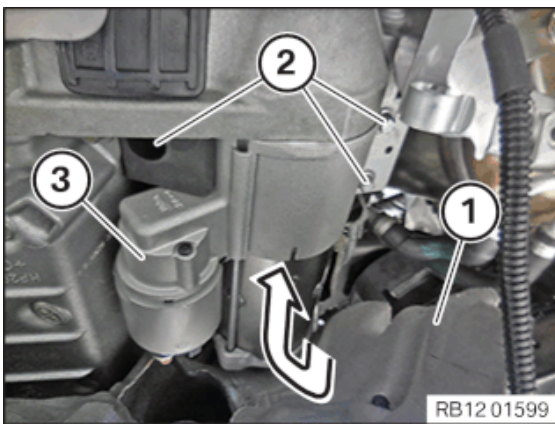

- Make sure that the acoustic cover (1) is not damaged.
- Carefully press the acoustic cover (1) to one side.
- Feed in and install the starter motor (3) in the direction of the arrow.
- Tighten the screws (2).

#### Starter motor to crankcase

M8x60	Tightening torque	19 Nm
-------	-------------------	-------

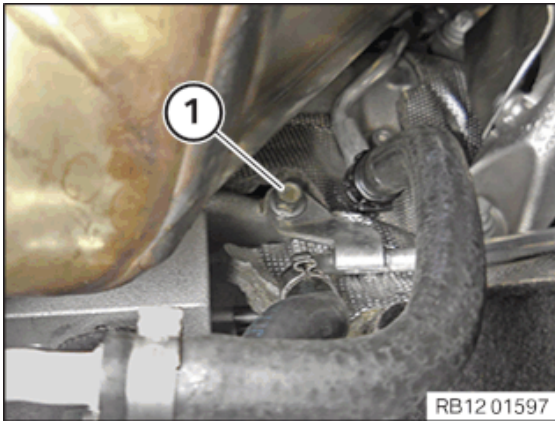

- Mount the coolant lines.
- Tighten down screw (1).

#### Coolant line to crankcase/diesel particulate filter

M6x16		8 Nm
-------	--	------

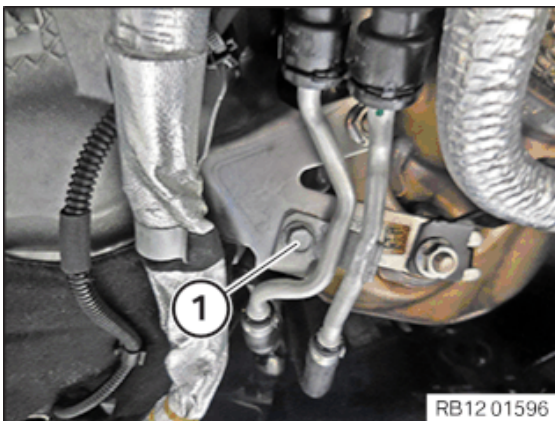

- Mount the coolant lines.
- Tighten down screw (1).

#### Coolant line to crankcase/diesel particulate filter

M6x16		8 Nm
-------	--	------

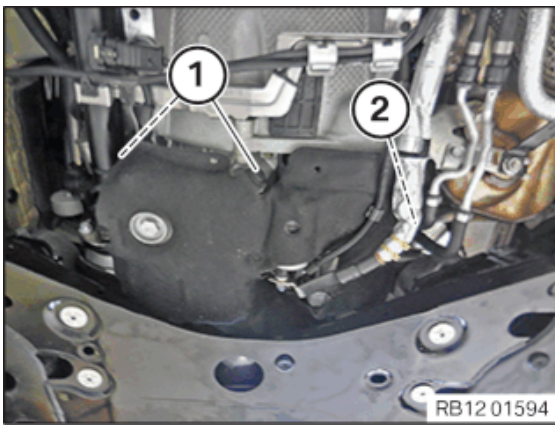

- Position acoustic cover.
  - Mount the expanding rivets (1) in the rear on the acoustic cover.
  - Renew the clip (2).
- Parts:** clip
- Mount the clip (2).

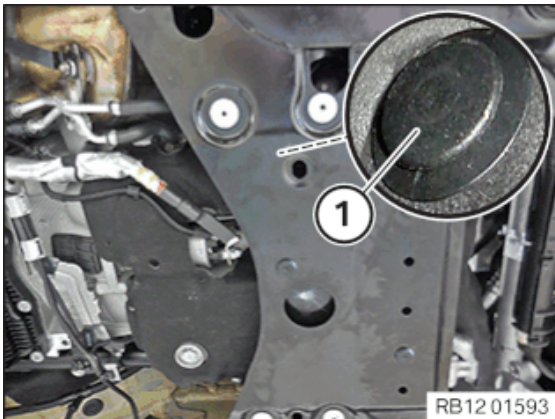

- Mount the expanding rivets (1) in the centre of the acoustic cover.

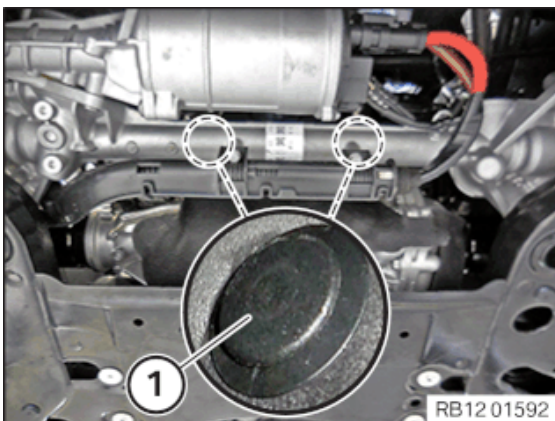

- Mount the expanding rivets (1) in the front on the acoustic cover.

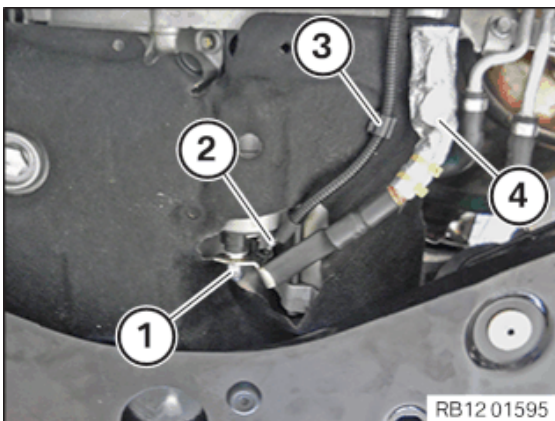

- **Version A:**
- Connect the cable (terminal 50) to the starter motor and secure it with the nut (2).
- Tighten nut (2).

**Terminal 50 to starter motor**

M6	Tightening torque	7,5 Nm
----	-------------------	--------

- Connect the positive battery cable to the starter motor and secure it with the nut (1).
- Tighten nut (1).

**Battery positive lead to starter**

M8	Tightening torque	13,5 Nm
----	-------------------	---------

- Secure the cable (terminal 50) at the clamp (3).
- Secure positive battery cable at the clamp (4).

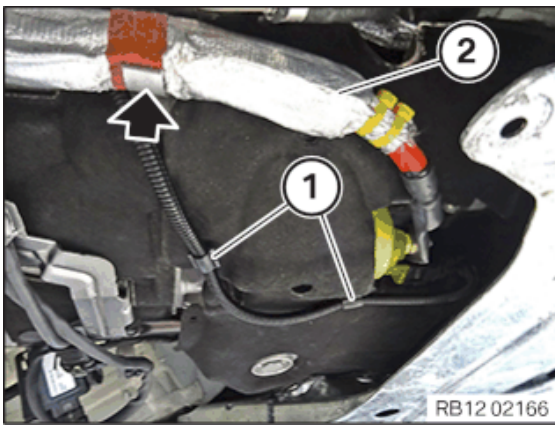

• **Version B:**

Secure and position positive battery cable (2) on the holder (arrow).

Secure clamps (1).

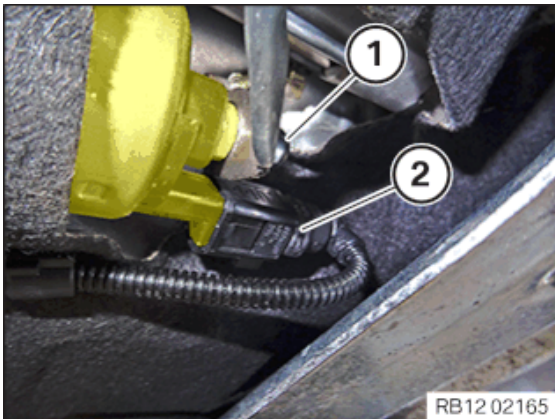

- Connect connectors (2) and lock.  
The connector (2) must engage audibly.
- Tighten the nut (1) hand-tight.

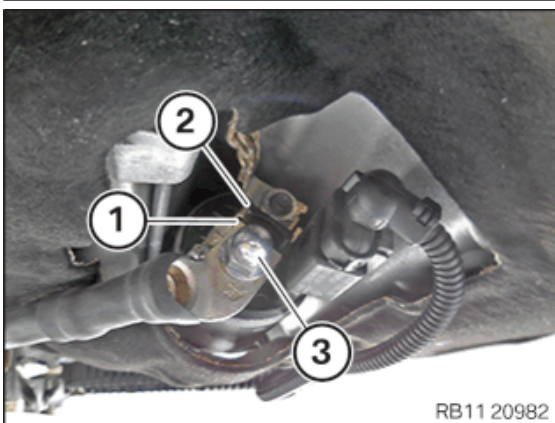

**Improper routing of the positive battery cable.**

**Risk of short circuits!**

- Route the positive battery cable without abrasions and do not trap.

- Attach the positive battery cable (1) **correctly** to anti-twist lock (2).
- Tighten nut (3).

**Terminal 50 to starter motor**

M6	Tightening torque	7,5 Nm
----	-------------------	--------

► **Installing the starter motor for vehicles with rear-wheel drive**

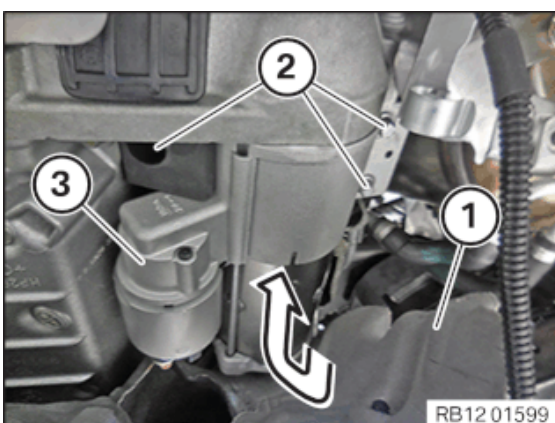

- Make sure that the acoustic cover (1) is not damaged.
- Carefully press the acoustic cover (1) to one side.
- Feed in and install the starter motor (3) in the direction of the arrow.
- Tighten the screws (2).

**Starter motor to crankcase**

M8x60	Tightening torque	19 Nm
-------	-------------------	-------

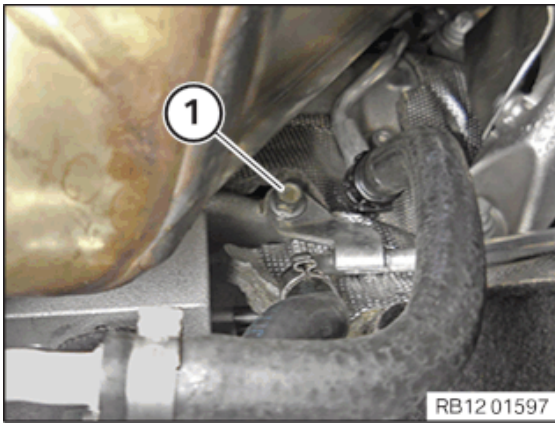

- Mount the coolant lines.
- Tighten down screw (1).

**Coolant line to crankcase/diesel particulate filter**

M6x16

8 Nm

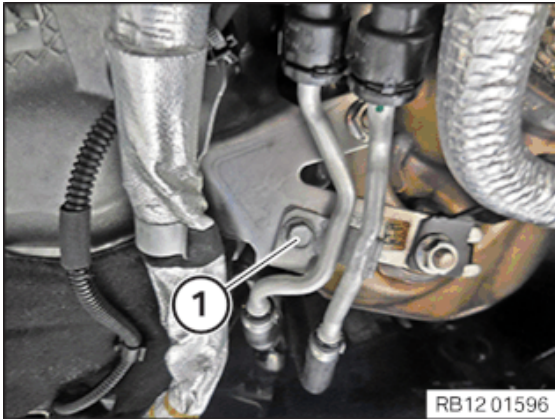

- Mount the coolant lines.
- Tighten down screw (1).

**Coolant line to crankcase/diesel particulate filter**

M6x16

8 Nm

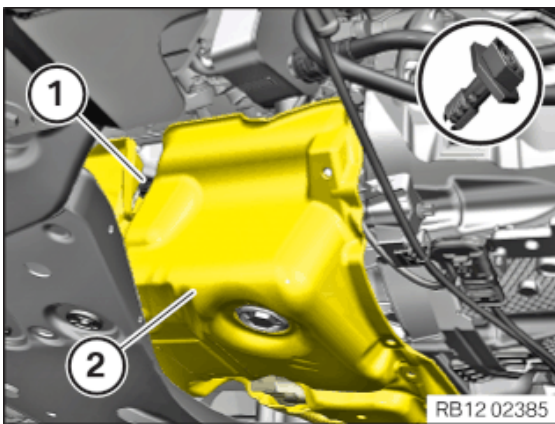

- Position the acoustic cover (2) of the oil sump.
- Secure expanding rivet (1).

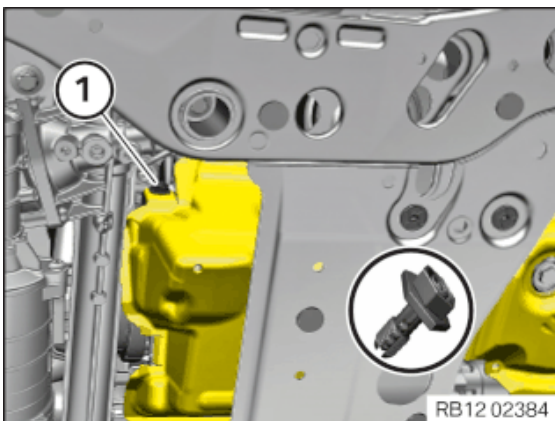

- Secure expanding rivet (1).

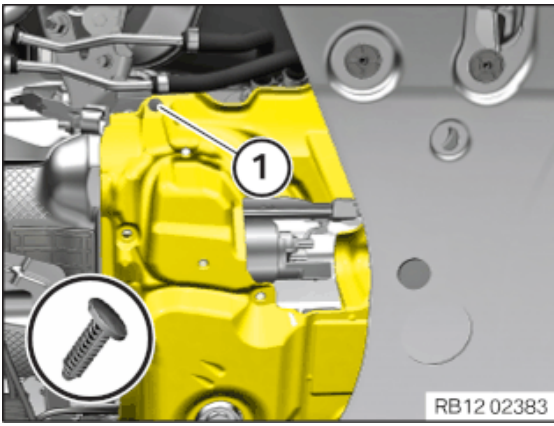

- Renew the fir tree clip (1).
- **Parts:** Fir tree clip
- Secure the fir tree clip (1).

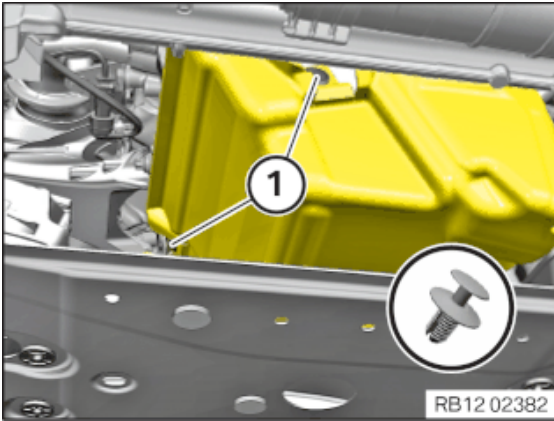

- Secure expanding rivet (1).

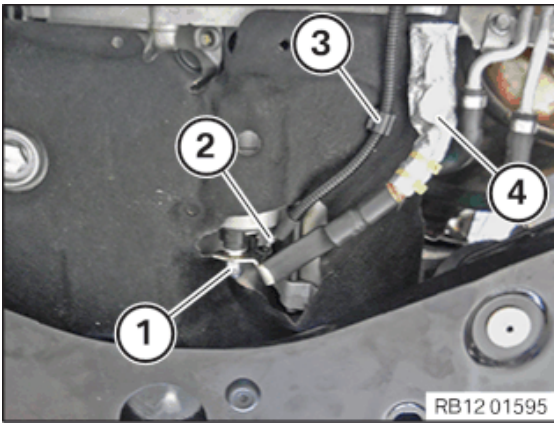

- **Version A:**
- Connect the cable (terminal 50) to the starter motor and secure it with the nut (2).
- Tighten nut (2).

**Terminal 50 to starter motor**

M6	Tightening torque	7,5 Nm
----	-------------------	--------

- Connect the positive battery cable to the starter motor and secure it with the nut (1).
- Tighten nut (1).

**Battery positive lead to starter**

M8	Tightening torque	13,5 Nm
----	-------------------	---------

- Secure the cable (terminal 50) at the clamp (3).
- Secure positive battery cable at the clamp (4).

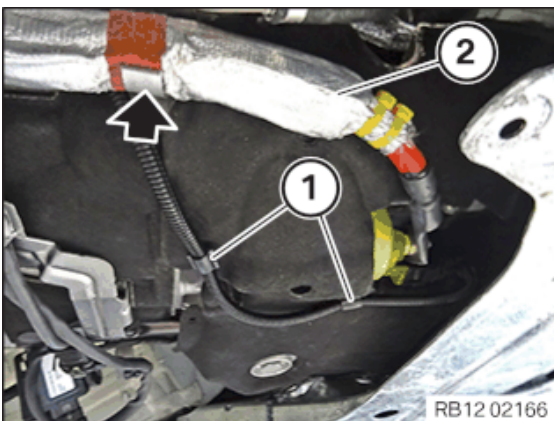

- **Version B:**
- Secure and position positive battery cable (2) on the holder (arrow).
- Secure clamps (1).

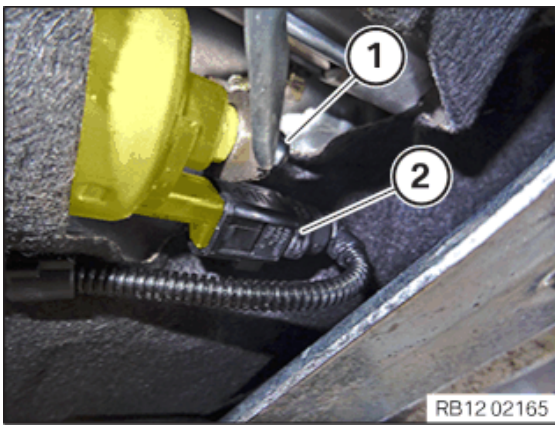

- Connect connectors (2) and lock.  
The connector (2) must engage audibly.
- Tighten the nut (1) hand-tight.

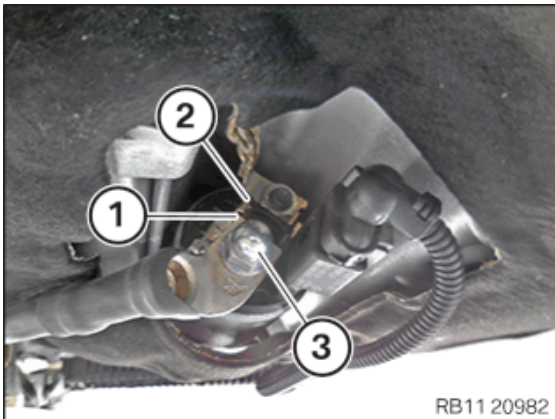

#### **Improper routing of the positive battery cable.**

#### **Risk of short circuits!**

- Route the positive battery cable without abrasions and do not trap.
- Attach the positive battery cable (1) **correctly** to anti-twist lock (2).
- Tighten nut (3).

#### **Terminal 50 to starter motor**

M6

Tightening  
torque

7,5 Nm

## **22 – Installing the exhaust system**



#### **Component with heavy weight.**

#### **Danger of injury!**

- Note component's centre of gravity.
- Support component using a jack.
- Secure component against falling off the jack.



#### **Heavy component.**

#### **Heavy components can lead to injury or damage.**

- Remove and install heavy components with the aid of another person/other persons.



#### **Grinding dust when grinding components.**

#### **Hazardous to health!**

- Directly draw off the grinding dust.
- Ensure adequate ventilation.
- Conduct all work in appropriate personal protective equipment only.



Mount the exhaust system in voltage-free state, maintaining the tightening sequence from the rear silencer towards the exhaust manifold.

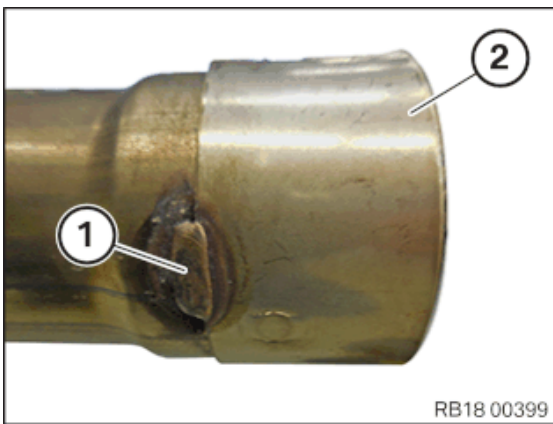
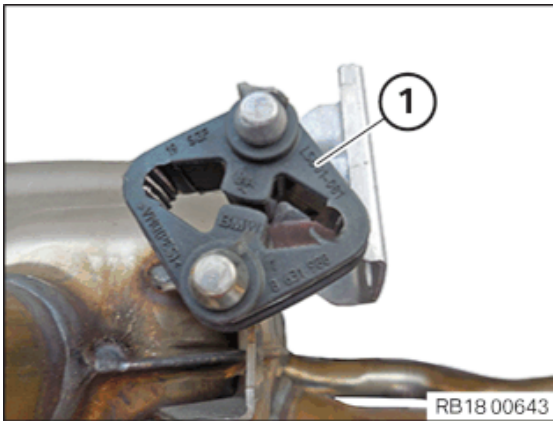

Schematic diagram is for example purposes. Some parts may differ in certain details.

- Check all the rubber mounts (1) of the exhaust system for damage.
- Replaced damaged rubber mounts.

**Parts:** Rubber mount



**Swarf resulting from sawing or grinding components.**

**Danger of injury!**



- Conduct all work in appropriate personal protective equipment only.



- Wear safety goggles and protective gloves.

- Open the weld seam (1) with a conventional tool.
- Remove the current clamp (2).
- Tighten nut (1).

#### Rear silencer to bumper support

M8	Tightening torque	19 Nm
----	-------------------	-------

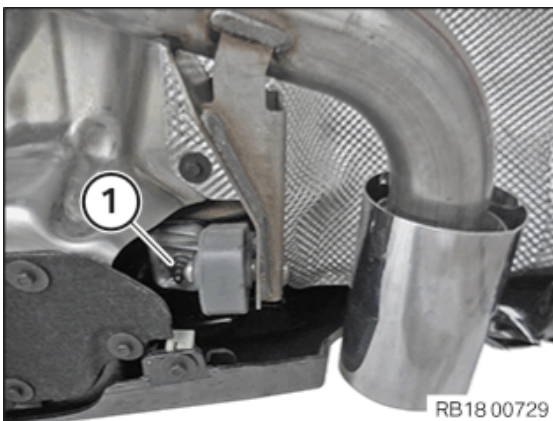

- Tighten nut (1).

#### Rear silencer to bumper support

M8	Tightening torque	19 Nm
----	-------------------	-------

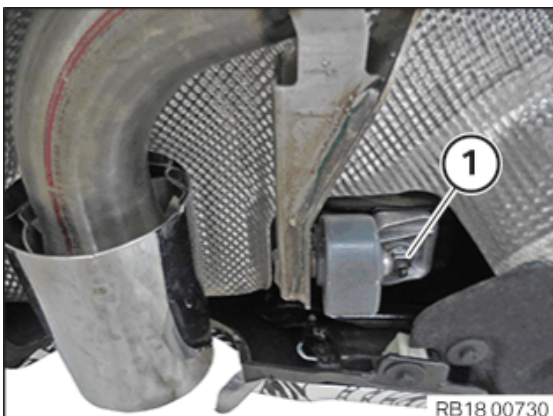

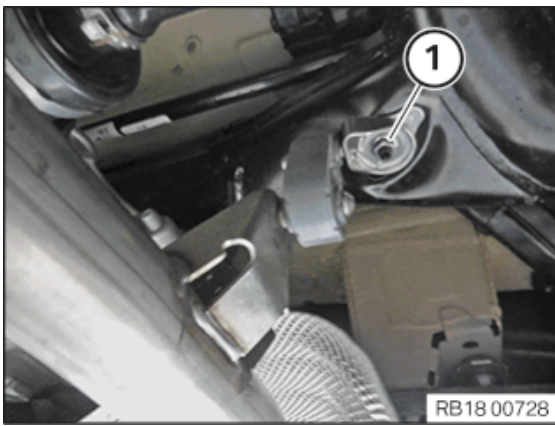

- Tighten nut (1).

#### Exhaust system to rear axle carrier

M8 nut		Tightening torque	19 Nm
--------	--	-------------------	-------

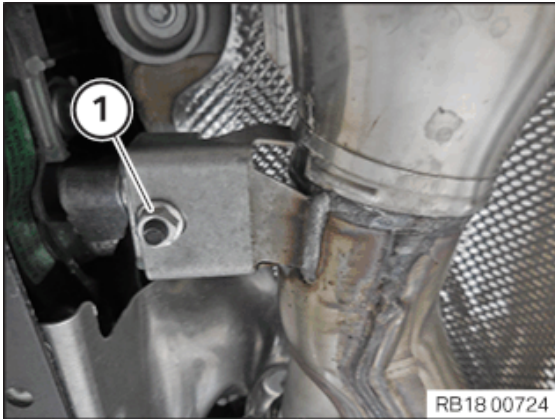

- Tighten nut (1).

#### Exhaust system to transmission

M8		Tightening torque	19 Nm
----	--	-------------------	-------

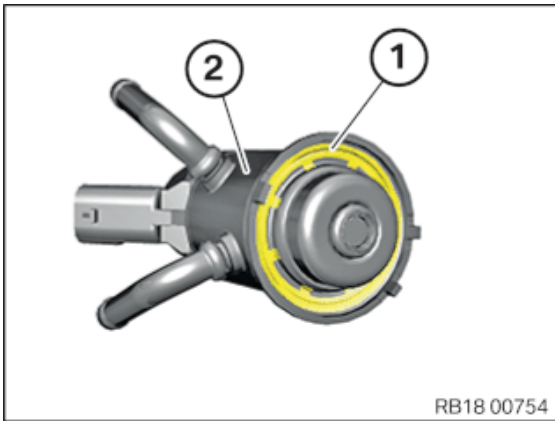

- Renew sealing ring (1) of the SCR metering module (2).

**Parts:** Sealing ring

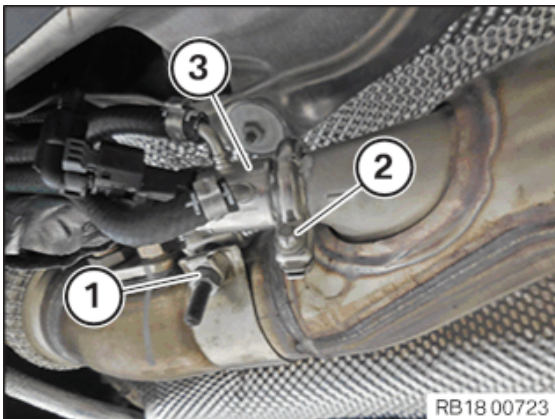

- If necessary, renew clamp (1).

**Parts:** Clamp

- Guide in the exhaust system with the assistance of a second person and connect it to the diesel particulate filter.

- Tighten clamp (1).

#### Exhaust system to diesel particle filter

M8	If necessary, renew clamp.	Tightening torque	26 ±2 Nm
----	----------------------------	-------------------	----------

- Renew the V-clip (2).

**Parts:** V-band clamp

- Install the SCR metering module (3) in the exhaust system.

- Tighten the V-clip (2) of the SCR metering module (3).

#### SCR metering module V-clip to exhaust system

V-band clamp	Renew V-band clamp.	Tightening torque	8 Nm
--------------	---------------------	-------------------	------

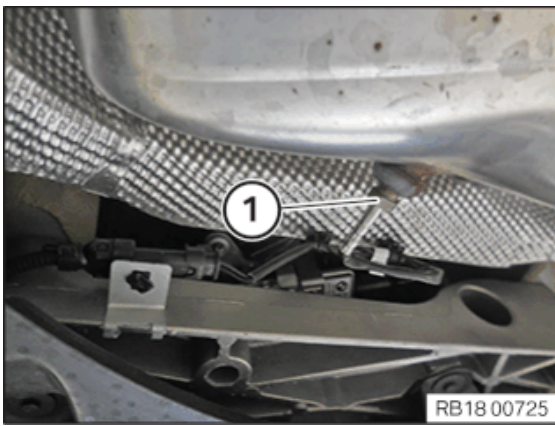

- Install the exhaust temperature sensor (1) in the exhaust system and tighten.

#### Exhaust-gas temperature sensor upstream of SCR catalytic converter

Sensor	Tightening torque	30 Nm
--------	-------------------	-------

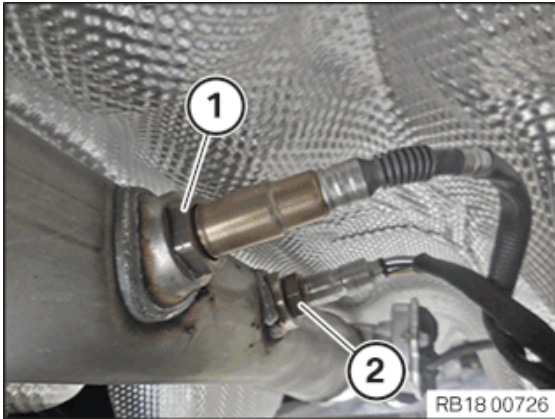

- Install the diesel particulate sensor (1) in the exhaust system and tighten.

#### Diesel particulate sensor to exhaust system

Sensor	Tightening torque	50 Nm
--------	-------------------	-------

- Install the nitrogen oxide sensor (2) in the exhaust system and tighten.

#### Nitrogen oxide sensor downstream of SCR catalytic converter

Sensor	Tightening torque	55 Nm
--------	-------------------	-------

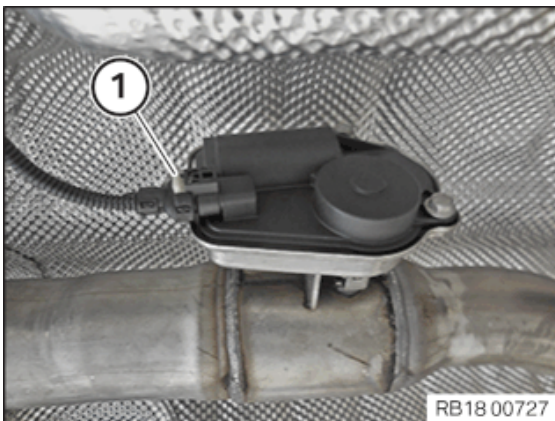

The following work step(s) is / are to be carried out if the specified component(s) is/are fitted.

- Connect connectors (1) and lock.  
The connector (1) must engage audibly.

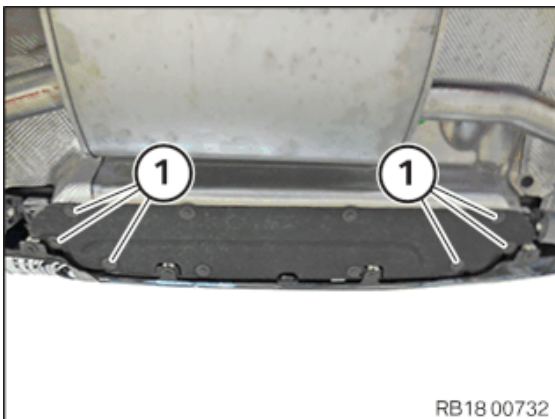

- Install cover.
- Tighten the screws (1).

#### Underbody panelling

Screw	Tightening torque	2,6 Nm
Plastic nut	Tightening torque	2,6 Nm

► If installed: Install the right torsion strut

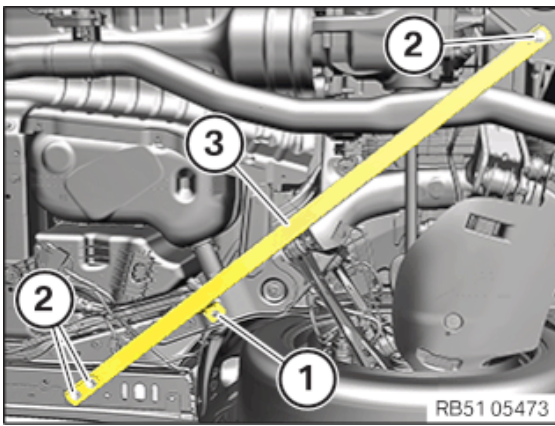

- Thread in torsion strut (3) at right and install.
- Renew screws (2).

**Parts:** Bolts

- Tighten down screws (2).

**Torsion strut to mounting**

M12	Renew screws.	Tightening torque	100 Nm
		Angle of rotation	90 °

- Tighten nut (1).

**Torsion strut to compression strut**

M8		Tightening torque	28 Nm
----	--	-------------------	-------

**23 – Install the connecting supports on the tunnel**

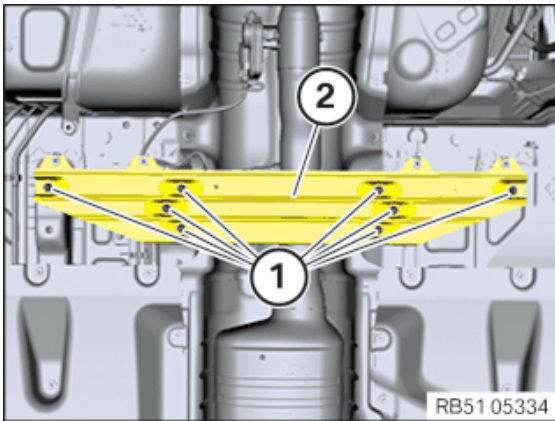

- Position the connecting support (2) on the tunnel.
- Tighten the screws (1).

**Connecting support on tunnel to body**

M8x25 screw		Tightening torque	20 Nm
-------------	--	-------------------	-------

**24 – Install tank cover on left and right**



The description is for one component only. The procedure is identical for all further components.

**► Installing tank cover**

- Guide in tank cover (2) and position correctly.
- Tighten all bolts (arrows) and the plastic nuts (1).

**Underbody panelling**

Screw		Tightening torque	2,6 Nm
Plastic nut		Tightening torque	2,6 Nm

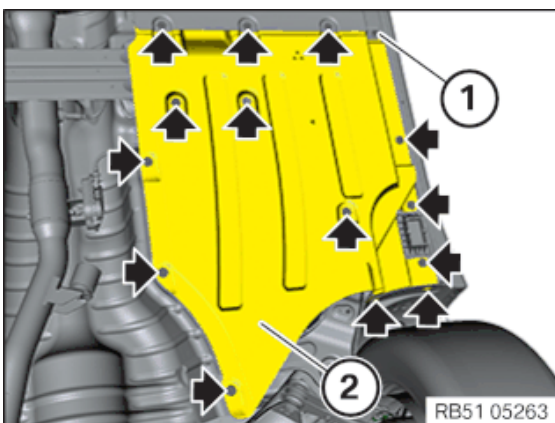

**25 – If installed: Install the underbody panelling of the transmission on the side**

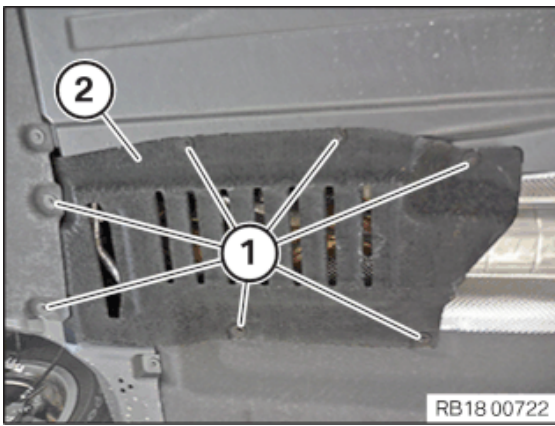

- Install the underbody panelling (2).
- Tighten the screws (1).

#### Underbody panelling

Screw	Tightening torque	2,6 Nm
Plastic nut	Tightening torque	2,6 Nm

## 26 – Connecting all battery earth leads



- See additional information.

## 27 – Checking/topping up oil level in automatic transmission

### Prerequisite

Vehicle is in a horizontal position.

The vehicle is secured against rolling away.



**Materials harmful to health.**

**Contact with fluids harmful to health!**

- Note and follow safety information on containers.
- Conduct all work in appropriate personal protective equipment only.



To set the correct oil level, it is mandatory that the service function "Transmission control unit: Oil-level adjustment" is carried out with the diagnosis system.



Carry out oil-level adjustment:

Certain fault memory entries may require an oil-level adjustment in the automatic transmission and after repairs have been completed (e.g. exchange of mechatronics, exchange of the converter, exchange of the transmission, automatic transmission oil service).



The automatic transmission fluid specified by BMW must be used for the automatic transmission.  
For additional information see: SBS-ANL-SBS1996-240596143\_A14 (automatic transmission fluid for ZF transmissions, etc.)

- Connect diagnosis system.
- Observe the predefined transmission oil temperatures for the oil-level adjustment with the diagnosis system:
  - Initial condition: Transmission oil temperature 30°C to 40°C.
  - Final condition: Transmission oil temperature 40°C to 50°C.
- Call up service function (drive).
- Carry out oil-level adjustment in accordance with the instructions.
- Loosen the oil filler plug (1) using the special tool **2 405 614**.
- Top up automatic transmission fluid according to the instructions in the diagnosis system.

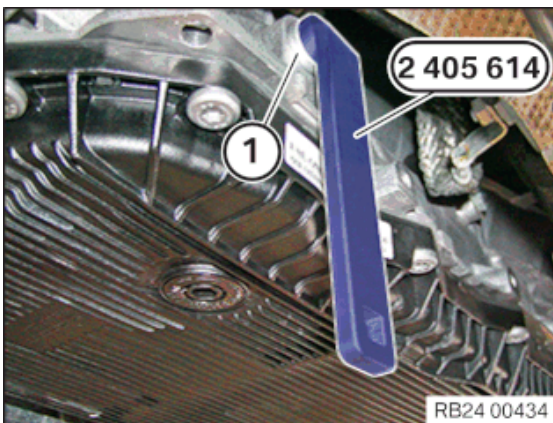

#### GA8HP51Z transmission capacity

min. 9,28 l

Transmission oil: Automatic transmission fluid ATF 3+

#### GA8HP76Z transmission capacity

min. 9,35 l

Transmission oil: Automatic transmission fluid ATF 3+

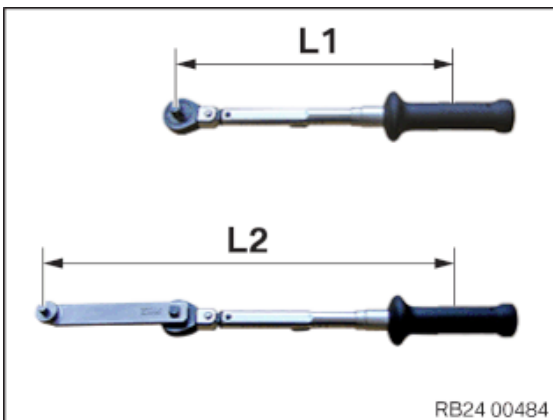

The setpoint torque deviates from the torque to be set when using special tool 2 405 614.

- Converting the setpoint torque into the torque to be set:  
(setpoint torque x L1) : L2 = Torque to be set  
L1 = Length from the centre of the handle to the reversible ratchet head  
L2 = Length from the centre of the handle to the engaging of the special tool in the bolt
  - Renew the oil filler plug (1) and the sealing ring.
- Parts:** Oil filler plug, sealing ring
- Make sure that the special tool **2 405 614** and the torque wrench (2) align while tightening the oil filler plug (1).
  - Tighten the oil filler plug (1) with the special tool **2 405 614** and the torque wrench (2).

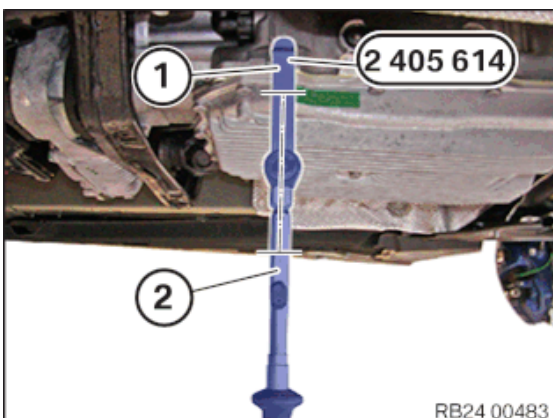

#### Oil filler plug

M18x1.5	Tightening torque	35 Nm
---------	-------------------	-------

## 28 – Install acoustic cover for the engine, front

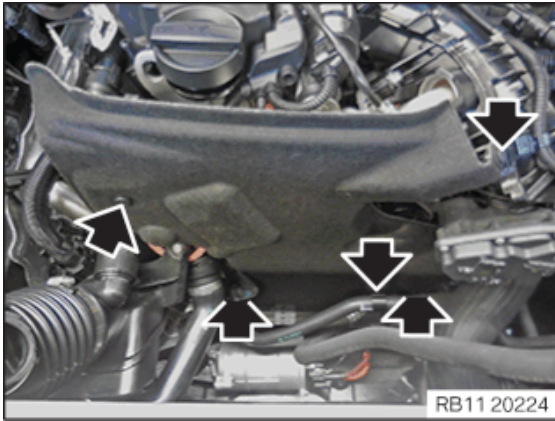

- Feed the acoustic cover in and install.
- Secure the acoustic cover using the clamps (arrows).

## 29 – Install resonator

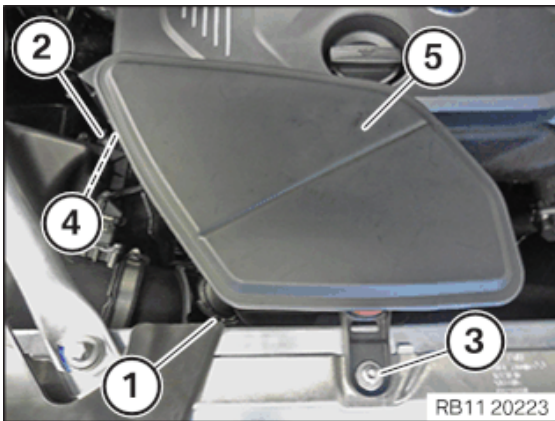

- Insert and install the resonator (5).
- Tighten clamp (1).

### Resonator to clean air pipe

Clamp	Tightening torque	3 Nm
-------	-------------------	------

- Tighten down screw (2).

### Resonator to intake filter housing

Screw	Tightening torque	2,8 Nm
-------	-------------------	--------

- Tighten down screw (3).

### Resonator on the cross connection

	Tightening torque	11,8 Nm
--	-------------------	---------

- Secure clamps (4).

## 30 – Install acoustic cover



### Damage to the acoustic cover/design cover.

**Jerky movements during disassembly and excessive application of force during installation may result in breakage of the acoustic cover/design cover.**

- Disassemble or mount the acoustic cover/design cover carefully.
- Disassemble or mount snap-lock couplings of the ball pivots one after the other.
- Disassemble or mount acoustic cover/design cover only at temperatures >20 °C.
- Use only distilled water as an auxiliary material during installation, no lubricants.

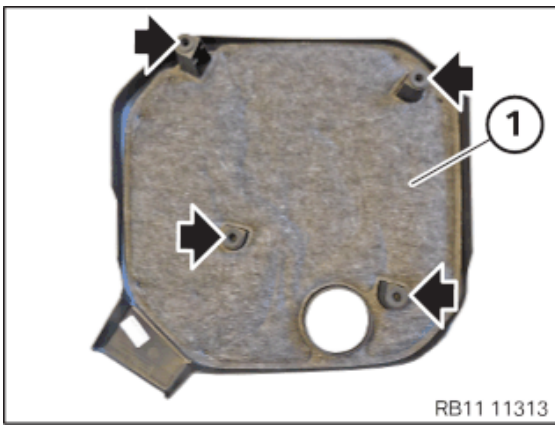

- Check for correct installation of all rubber mounts (arrows) in the acoustic cover (1).

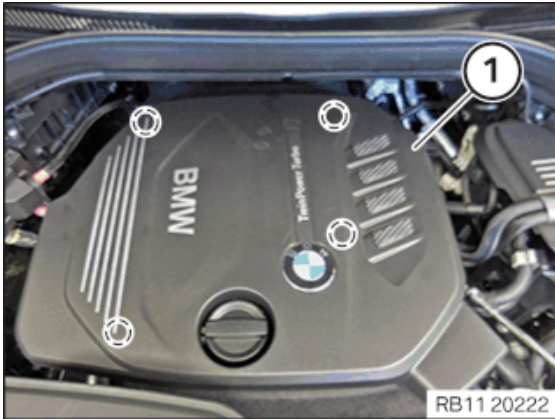

- Clip in the acoustic cover (1) into the holders in the indicated areas.
- Make sure that the acoustic cover (1) engages audibly.

### 31 – Installing the front underbody protection

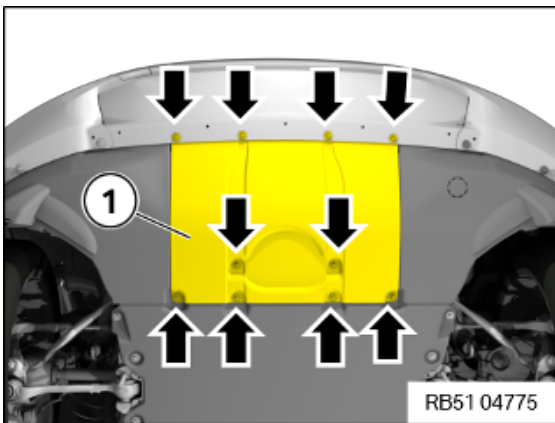

- Insert the front underbody protection (1).
- Tighten screws (arrows).

#### Underbody protection

Hexagon screw	Tightening torque	3 Nm
---------------	-------------------	------

### 32 – Installing the centre underbody protection

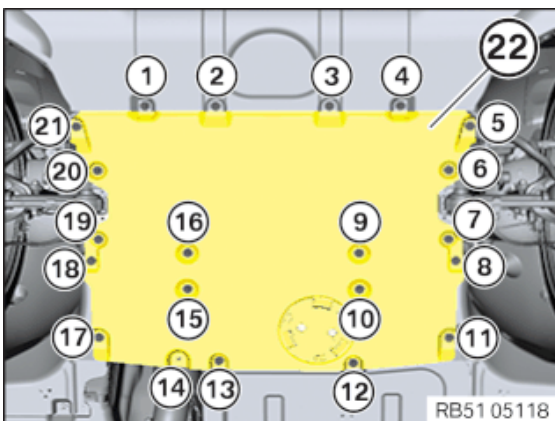

- Guide in the centre underbody protection (22) at an angle toward the front.
- Tighten the screws (1) to (21).

#### Underbody protection

Hexagon screw	Tightening torque	3 Nm
---------------	-------------------	------

### 33 – Installing underbody protection at rear

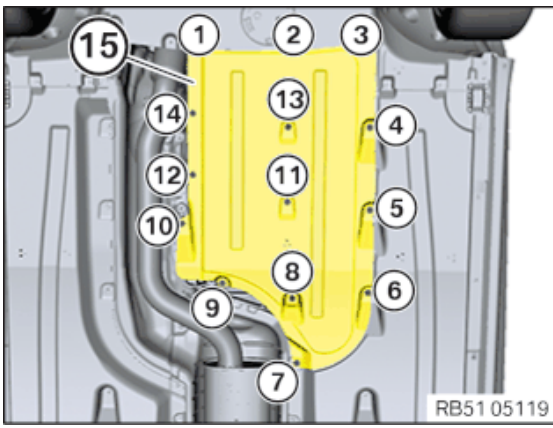

- Guide in the rear underbody protection (15) at an angle toward the front.
- Tighten the screws (1) to (14).

### Underbody protection

Hexagon screw	Tightening torque	3 Nm
---------------	-------------------	------

## Additional Information

### Overview of Tightening Torques

<b>Torque converter to flywheel</b>		Used in step <a href="#">17</a>	
M10	Renew screws.	Tightening torque	56 Nm
<b>Bracket to transmission for diesel particulate filter holder bottom</b>		Used in step <a href="#">17</a>	
M8X20		Tightening torque	19 Nm
<b>Lower holder to diesel particulate filter</b>		Used in step <a href="#">17</a>	
M8		Tightening torque	19 Nm
<b>Coolant line to crankcase/diesel particulate filter</b>		Used in step <a href="#">17</a> <a href="#">21</a>	
M6x16			8 Nm
<b>Transmission to engine</b>		Used in step <a href="#">17</a>	
M8		Tightening torque	19 Nm
M12		Tightening torque	66 Nm
<b>Transmission oil line to transmission</b>		Used in step <a href="#">17</a>	
M6x25	Renew the sealing ring.	Tightening torque	8 Nm
<b>Ground strap to transmission or body</b>		Used in step <a href="#">17</a>	
M8		Tightening torque	19 Nm
<b>Transmission cross member to rubber mounts</b>		Used in step <a href="#">17</a>	
M12		Tightening torque	100 Nm
<b>Transmission cross member to body</b>		Used in step <a href="#">17</a>	
M8		Tightening torque	19 Nm
<b>Front flexible disc to propeller shaft</b>		Used in step <a href="#">18</a>	
M12	Renew screws.	Jointing torque	55 Nm
	Comply with jointing torque and angle of rotation.	Angle of rotation	90 °
	Tightening via screw.		

<b>Centre mount to body</b>			Used in step <a href="#">18</a>
M8		Tightening torque	19 Nm
<b>Retaining plates for vehicle underbody cover</b>			Used in step <a href="#">19</a>
Sheet metal nut/plastic nut	Renew nuts.	Tightening torque	3 Nm
<b>Heat shield to undercarriage</b>			Used in step <a href="#">20</a>
Screws and nuts		Tightening torque	3 Nm
<b>Starter motor to crankcase</b>			Used in step <a href="#">21</a>
M8x60		Tightening torque	19 Nm
<b>Terminal 50 to starter motor</b>			Used in step <a href="#">21</a>
M6		Tightening torque	7,5 Nm
<b>Battery positive lead to starter</b>			Used in step <a href="#">21</a>
M8		Tightening torque	13,5 Nm
<b>Rear silencer to bumper support</b>			Used in step <a href="#">22</a>
M8		Tightening torque	19 Nm
<b>Exhaust system to rear axle carrier</b>			Used in step <a href="#">22</a>
M8 nut		Tightening torque	19 Nm
<b>Exhaust system to transmission</b>			Used in step <a href="#">22</a>
M8		Tightening torque	19 Nm
<b>Exhaust system to diesel particle filter</b>			Used in step <a href="#">22</a>
M8	If necessary, renew clamp.	Tightening torque	26 ±2 Nm
<b>SCR metering module V-clip to exhaust system</b>			Used in step <a href="#">22</a>
V-band clamp	Renew V-band clamp.	Tightening torque	8 Nm
<b>Exhaust-gas temperature sensor upstream of SCR catalytic converter</b>			Used in step <a href="#">22</a>
Sensor		Tightening torque	30 Nm
<b>Diesel particulate sensor to exhaust system</b>			Used in step <a href="#">22</a>
Sensor		Tightening torque	50 Nm
<b>Nitrogen oxide sensor downstream of SCR catalytic converter</b>			Used in step <a href="#">22</a>
Sensor		Tightening torque	55 Nm
<b>Underbody panelling</b>			Used in step <a href="#">22</a> <a href="#">24</a> <a href="#">25</a>
Screw		Tightening torque	2,6 Nm
Plastic nut		Tightening torque	2,6 Nm

<b>Torsion strut to mounting</b>			Used in step <a href="#">22</a>
M12	Renew screws.	Tightening torque	100 Nm
		Angle of rotation	90 °
<b>Torsion strut to compression strut</b>			Used in step <a href="#">22</a>
M8		Tightening torque	28 Nm
<b>Connecting support on tunnel to body</b>			Used in step <a href="#">23</a>
M8x25 screw		Tightening torque	20 Nm
<b>Oil filler plug</b>			Used in step <a href="#">27</a>
M18x1.5		Tightening torque	35 Nm
<b>Resonator to clean air pipe</b>			Used in step <a href="#">29</a>
Clamp		Tightening torque	3 Nm
<b>Resonator to intake filter housing</b>			Used in step <a href="#">29</a>
Screw		Tightening torque	2,8 Nm
<b>Resonator on the cross connection</b>			Used in step <a href="#">29</a>
		Tightening torque	11,8 Nm
<b>Underbody protection</b>			Used in step <a href="#">31</a> <a href="#">32</a> <a href="#">33</a>
Hexagon screw		Tightening torque	3 Nm

## Overview of Special Tools

### 2 219 012 Hydraulic lifter



<b>Common</b>		Used in step <a href="#">16</a>
Usage	For raising and lowering various vehicle components.	
Included in the tool or work		
Storage location		
Replaced by		
In connection with		
SI-Number	01 05 90 (207)	

### 0 495 498 (23 4 050) Fixture

<b>Common</b>		Used in step <a href="#">16</a>
Usage	(universal gearbox holder) Support for removing and installing manual gearboxes and automatic transmissions for BMW & RR.	
Included in the tool or work		
Storage location	Individual	
Replaced by		
In connection		

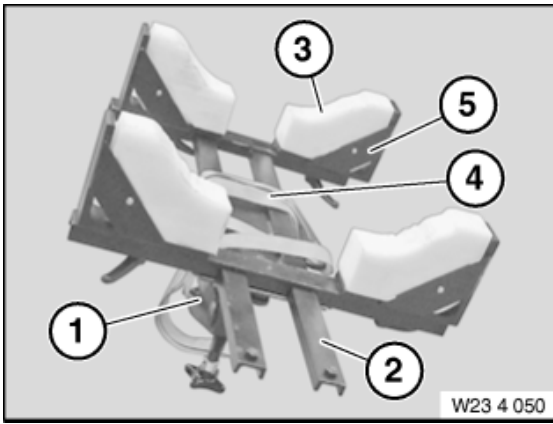

with

SI-Number 01 07 06 (256)

**Consisting of**

Pos	BMW Order number	Replaced by	Designation	In Connection with
3	<a href="#">0 495 549 (23 4 053)</a>		<b>Insert</b> (foam inserts (1 set = 4 pcs.))	
1	<a href="#">0 495 547 (23 4 051)</a>		<b>Joint</b> Available only as a complete tool set 23 4 050 (83 30 0 495 498) - as of 16.07.12.	
2	<a href="#">0 495 548 (23 4 052)</a>		<b>Frame</b> (Basic frame) Available only as a complete tool set 23 4 050 (83 30 0 495 498) - as of 16.07.12.	
4	<a href="#">0 495 550 (23 4 054)</a>		<b>Belt</b> (Tensioning strap) Available only as a complete tool set 23 4 050 (83 30 0 495 498) - as of 16.07.12.	
5	<a href="#">0 496 018 (23 4 055)</a>		<b>Fixture</b> (Fixture for foam insert) Available only as a complete tool set 23 4 050 (83 30 0 495 498) - as of 16.07.12.	

**0 493 380 (11 6 480) Connector**

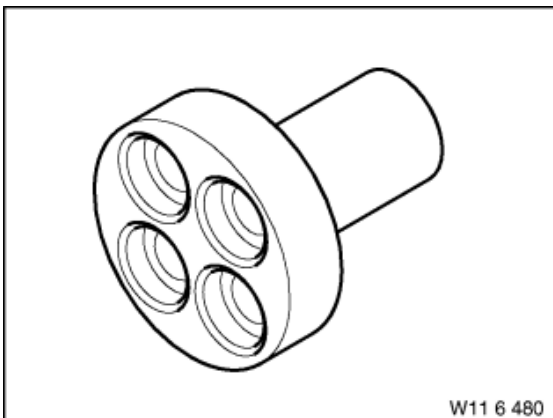

**Common**

Used in step [16](#) [17](#)

Usage

For turning over engine at crankshaft hub (vibration absorber).

Included in the tool or work

Storage location

Replaced by

In connection with

SI-Number 01 11 98 (338)

**0 494 478 (24 4 161) Basic body**

**Common**

Used in step [16](#)

Usage

Included in the tool or work

0 494 451

Storage location

B45

Replaced by

In connection

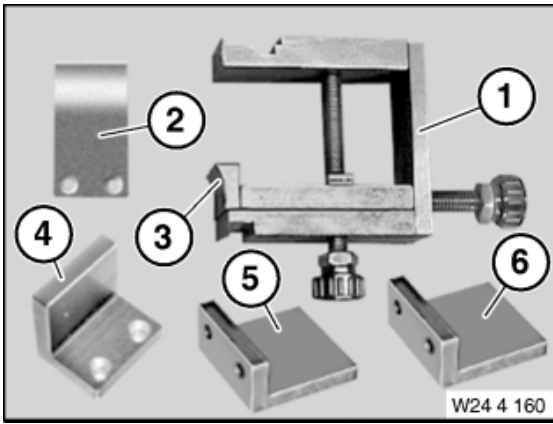

with  
SI-Number

**0 494 965 (24 4 165) Shaped element**

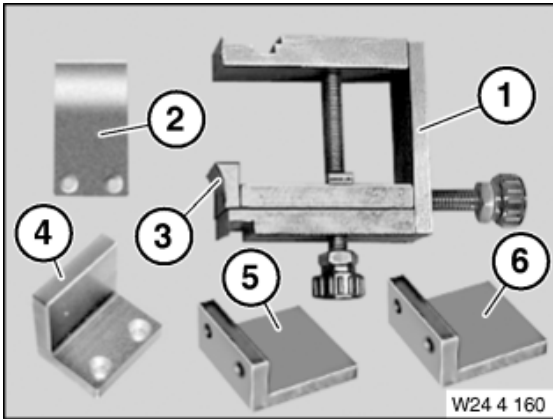

Common		Used in step	16
Usage	Gearbox: GA6 HP19 in E87, E90 Discontinued, available as part of set of special tools only		
Included in the tool or work	0 494 451		
Storage location	B45		
Replaced by			
In connection with			
SI-Number	01 15 04 (117)		

**0 494 451 (24 4 160) Holder**

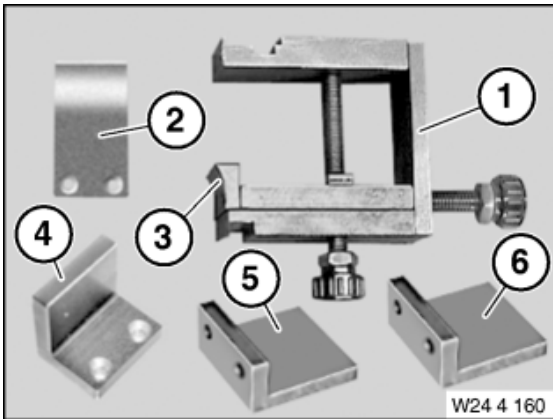

Common		Used in step	16	17
Usage	For securing converter during removal and installation of transmission			
Included in the tool or work				
Storage location	B45			
Replaced by				
In connection with				
SI-Number	01 11 02 (908)			

**Consisting of**

Pos	BMW Order number	Replaced by	Designation	In Connection with
2	<a href="#">0 494 479 (24 4 162)</a>		<b>Shaped element</b> For converter version N73 discontinued, available as part of set of special tools only	
5	<a href="#">0 494 965 (24 4 165)</a>		<b>Shaped element</b> Transmission: GA6 HP19 in E87, E90 Discontinued, available as part of set of special tools only	

3 [0 494  
477 \(24  
4 163\)](#)

**Shaped element**

For converter version  
M57TU discontinued,  
available as part of set of  
special tools only

1 [0 494  
478 \(24  
4 161\)](#)

**Basic body**

4 [0 494  
622 \(24  
4 164\)](#)

**Shaped element**

For converter version  
M54 discontinued,  
available as part of set of  
special tools only

6 [0 496  
061 \(24  
4 166\)](#)

**Shaped element**

Transmission: GA6L45R  
(GM6) in E83 / N52K  
Discontinued, available  
as part of set of special  
tools only

**0 494 213 (24 2 390) Cap**



**Common**

Used in step [16](#) [17](#)

Usage (protective cap) For sealing off the guide sleeve of the transmission connector

Included in the tool or work

Storage location C49

Replaced by

In connection with

SI-Number 01 14 01 (766)

**0 490 189 (00 2 550) Measurement aid**

**Common**

Used in step [17](#)

Usage (Depth gauge) E.g. for determining side clearance of transmission shaft and basic adjustment dimension for installing bevel pinion in rear axle final drives

Included in the tool or work

Storage location A4

Replaced by

In connection with

SI-Number

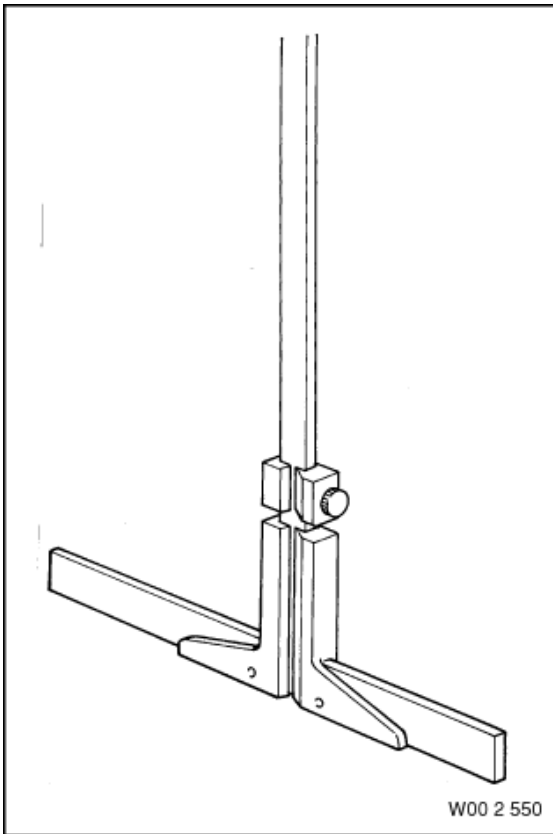

**0 491 667 (24 1 110) Socket wrench insert**

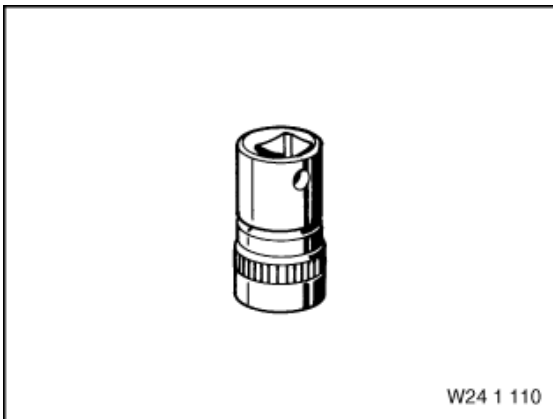

**Common**

Used in step [17](#)

Usage	Loosening and fastening the converter fastener
Included in the tool or work	
Storage location	A14
Replaced by	
In connection with	
SI-Number	01 04 86 (566)

**0 490 504 (00 9 120) Torque angle measuring dial**



**Common**

Used in step [18](#)

Usage	For torsion angle adjustment of cylinder head bolts (all engines) And reinforcement plate front axle support E46
Included in the tool or work	
Storage location	A4
Replaced by	
In connection with	
SI-Number	

**2 405 614 Socket wrench**

**Common**

Used in step [27](#)

Usage	For opening and closing the oil filler plug.
-------	--

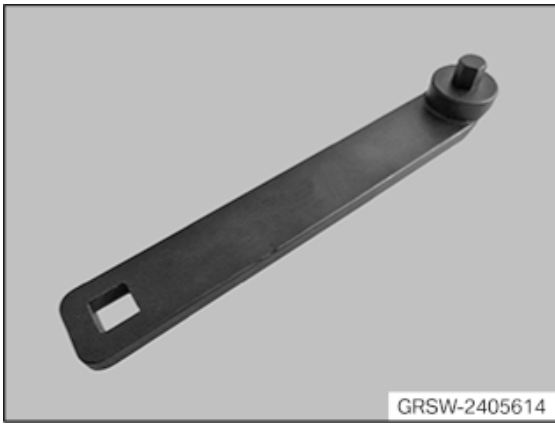

Contour-graphic silhouette foil is included in delivery specification. Further information on the contour-graphic silhouette foil can be found in service information 00 22 13 (969). Replaced by 2455997

Included in the tool or work

Storage location

Replaced by

In connection with

SI-Number 01 33 15 (305)

## Overview Technical Data

### GA8HP51Z transmission capacity

Used in step [27](#)

min. 9,28 l

Transmission oil: Automatic transmission fluid ATF 3+

### GA8HP76Z transmission capacity

Used in step [27](#)

min. 9,35 l

Transmission oil: Automatic transmission fluid ATF 3+