

# 11 00 598 Remove and install the engine on the front axle

## PRELIMINARY WORK

---

### 1 – Remove the front axle completely with the engine and transmission

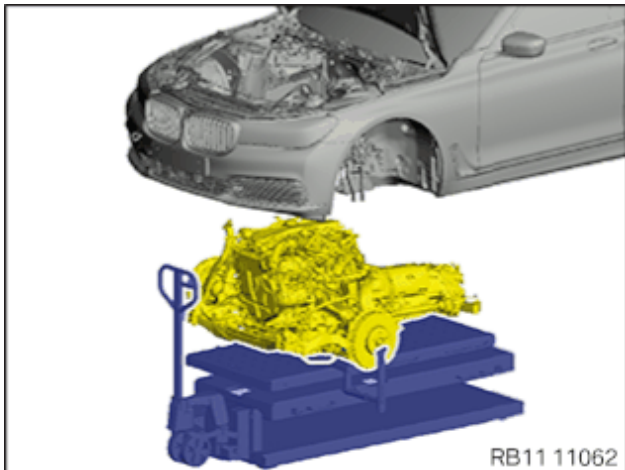

- See additional information.

### 2 – Removing the front drive shafts (on the mobile lifting table)



Carry out the following operations with an auxiliary person.



Perform the operations on the left and right side.

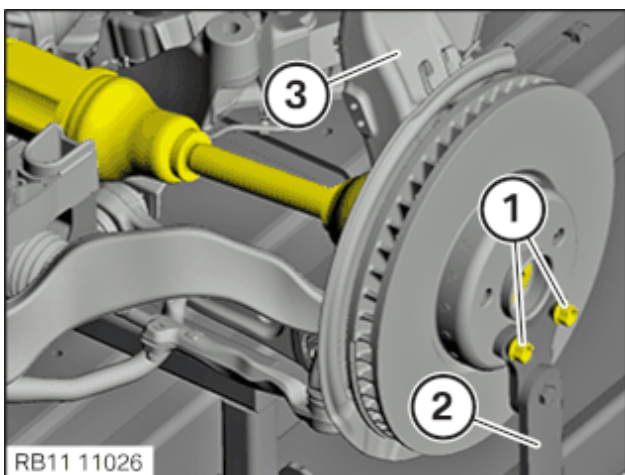

- Loosen screws (1).
- Remove the fixture (2) of the swivel bearing and set it aside.
- Hold the swivel bearing (3) with the special tool **2 220 718**.

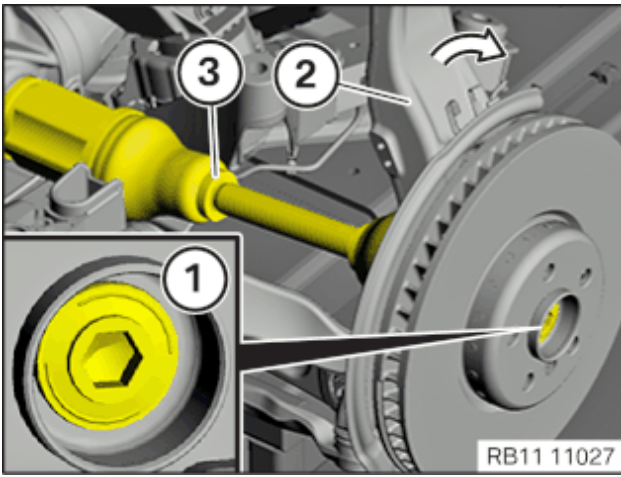

- Loosen screw (1).
- Tilt the swivel bearing (2) slightly forward.
- Loosen and remove the output shaft (3) at the front axle differential with a suitable tool.

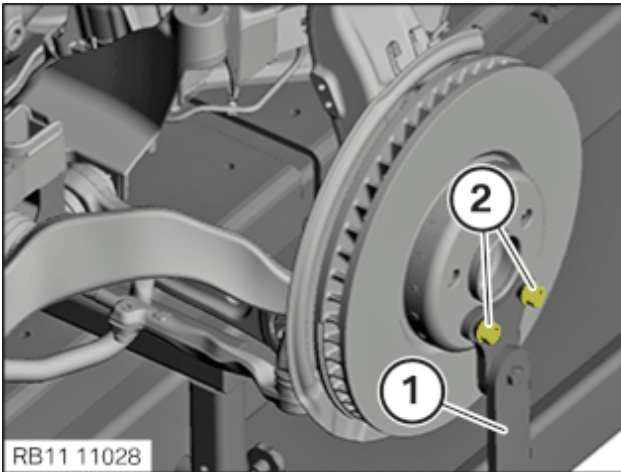

- Install the fixture (1) of the swivel bearing.
- Tighten the screws (2).

### 3 – Removing the acoustic cover for the engine at the front

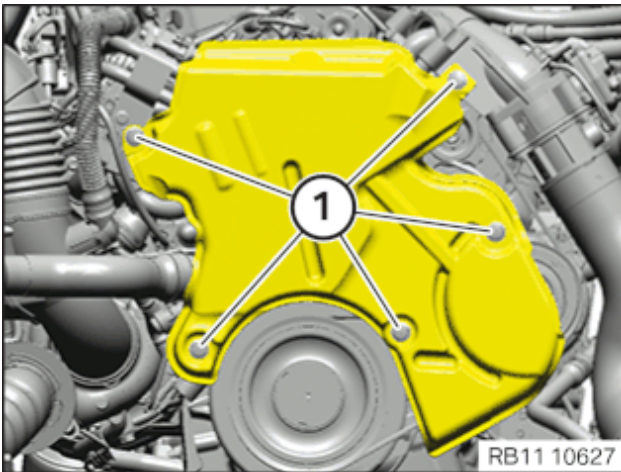

- Open the expanding rivets (1) and remove the acoustic cover.

### 4 – Removing acoustic cover at rear

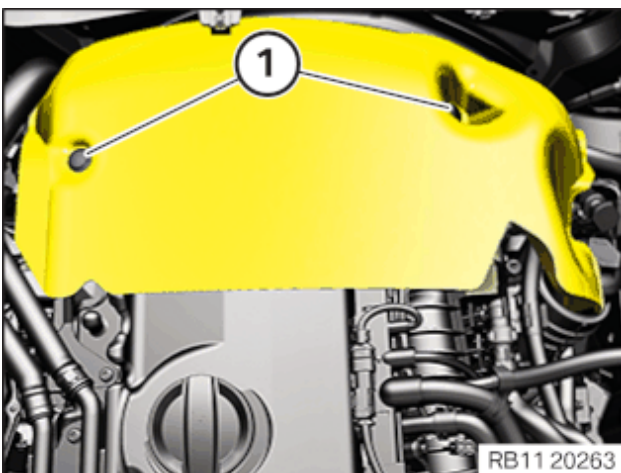

- Release the expanding rivets (1) and set aside.

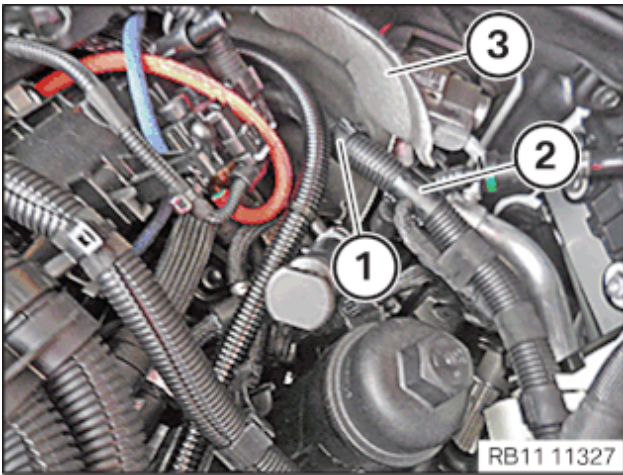

- Unlock and loosen clamp (1).
- Remove the wiring harness (2) and put to one side.
- Guide the acoustic cover (3) out and remove.

### 5 – Remove bottom clean air pipe

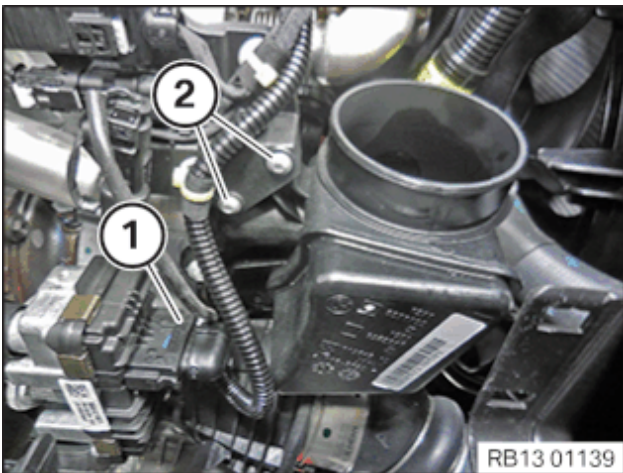

- Unlock plug connection (1) and disconnect.
- Loosen screws (2).

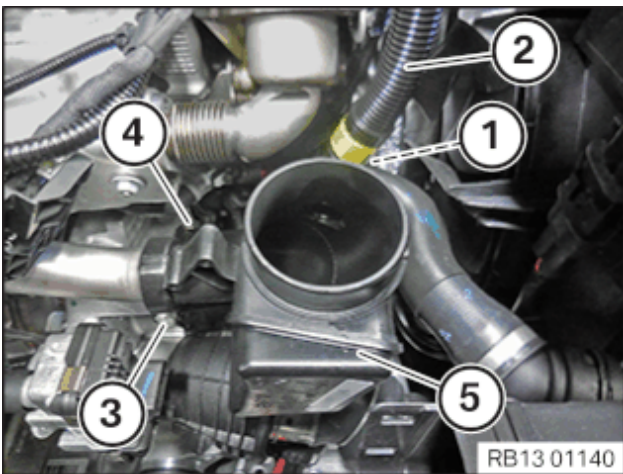

- Unlock and loosen lock (1).
- Guide the line (2) out and set it aside.
- Loosen screw (3).
- Loosen clamp (4).
- Feed out lower clean air pipe (5) and remove.

### 6 – Remove diesel particulate filter (on mobile lifting table)

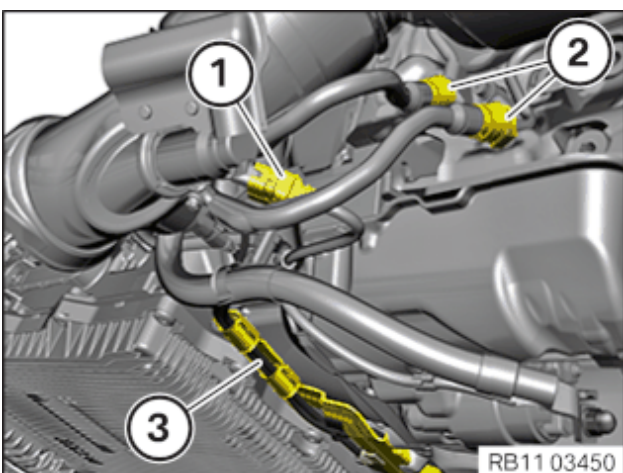

- Disconnect the plug connection (1) on the SCR metering module.
- Unlock and pull off the coolant hoses (2).
- Detach wiring harness from the holder (3).

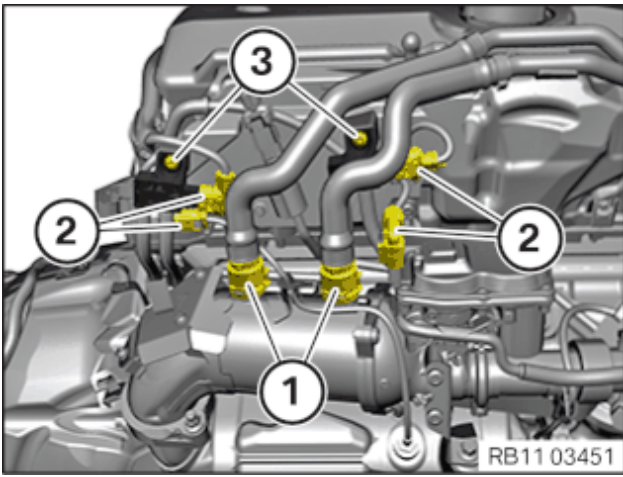

- Unlock and pull off the coolant hoses (1).
- Unlock and disconnect plug connections (2).
- Loosen screws (3).
- Guide out the differential pressure sensors.

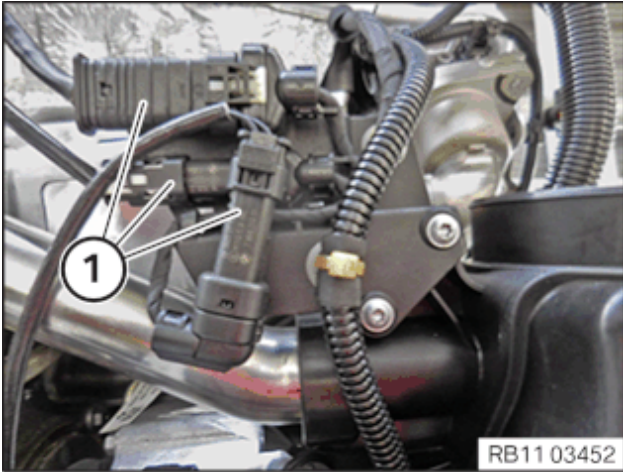

- Unfasten plug connections (1).

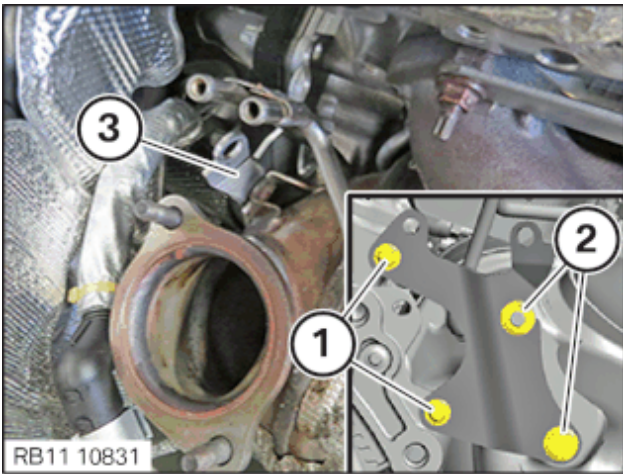

- Loosen screws (1).
- Unscrew the bolt (2) and the nut (2).
- Disassemble sheet metal bracket (3) of the diesel particulate filter on the cylinder head.

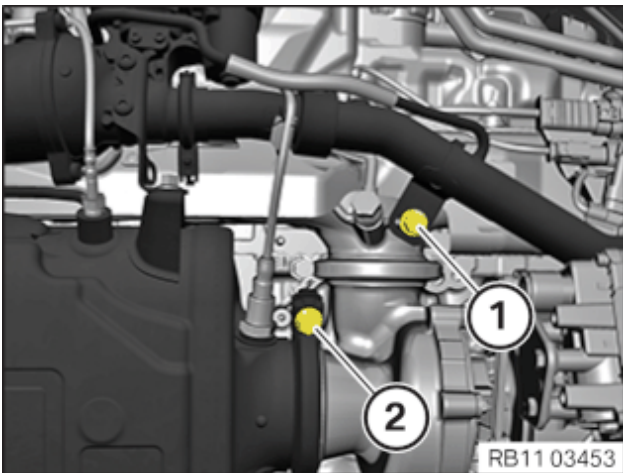

- Release the bolt (1) on the exhaust pipe.
- Loosen screw (2).
- Guide out the diesel particulate filter with low-pressure exhaust-gas recirculation cooler, differential pressure sensors and exhaust pipe and remove.
- Unclip lines.

## 7 – Removing the assembly (engine removed)

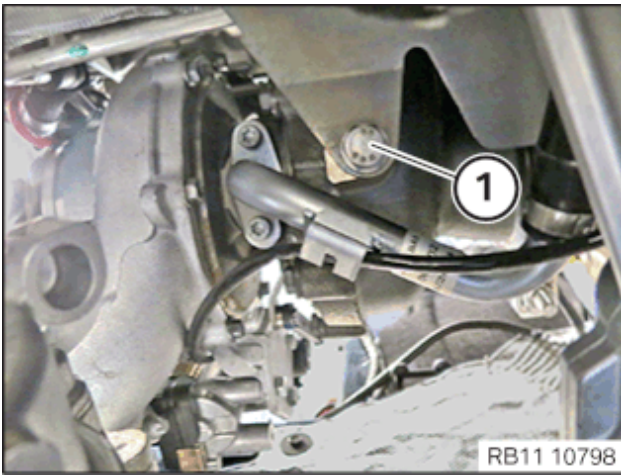

- Loosen screw (1).

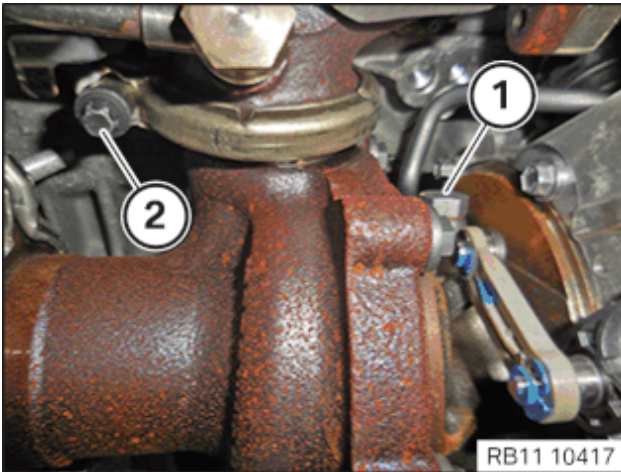

- Release the banjo bolt (1) of the oil feed line.
- Loosen screw (2).
- Remove the V hose clamp.
- Thread out and remove exhaust turbocharger .

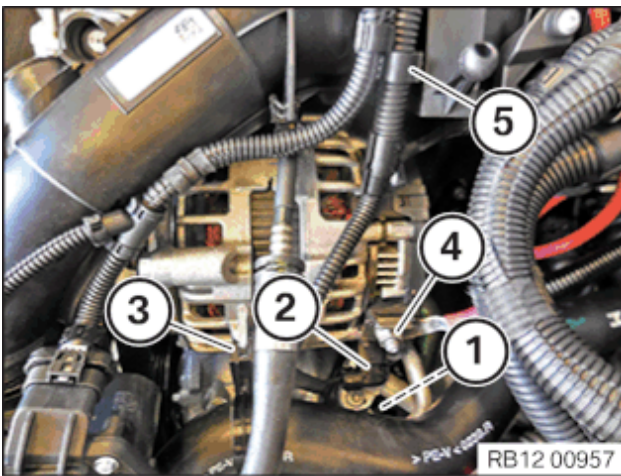

- Unlock and loosen the connector (1) on the air conditioning compressor.
- Unlock and loosen the connector (2) on the alternator.
- Loosen holder (3).
- Loosen nut (4), remove positive battery cable and place to one side.
- Unlock and loosen clamp (5).

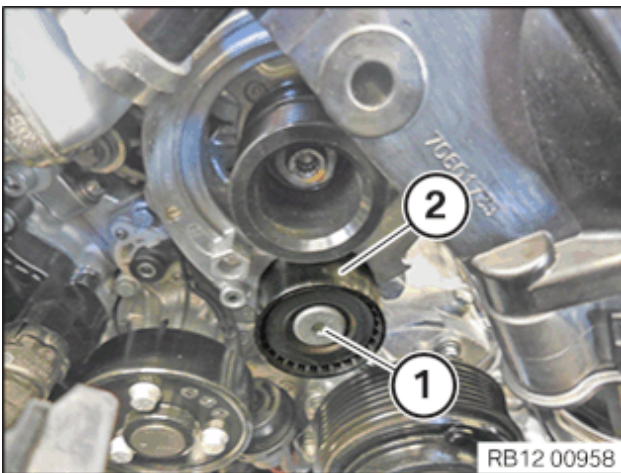

- Loosen screw (1).
- Remove the deflecting element (2).

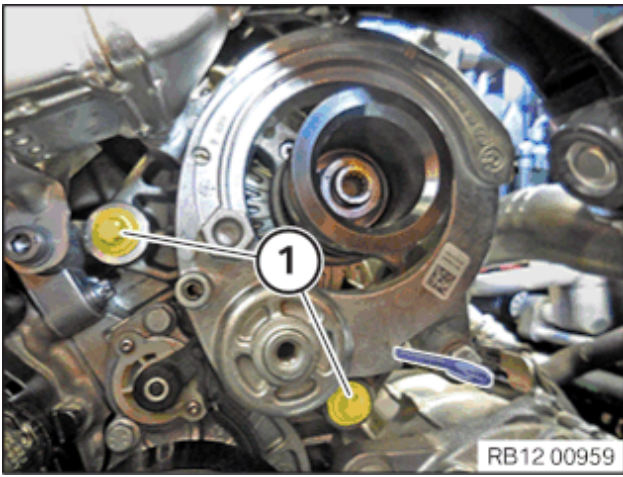

- Loosen screws (1).
- Feed out alternator and remove.

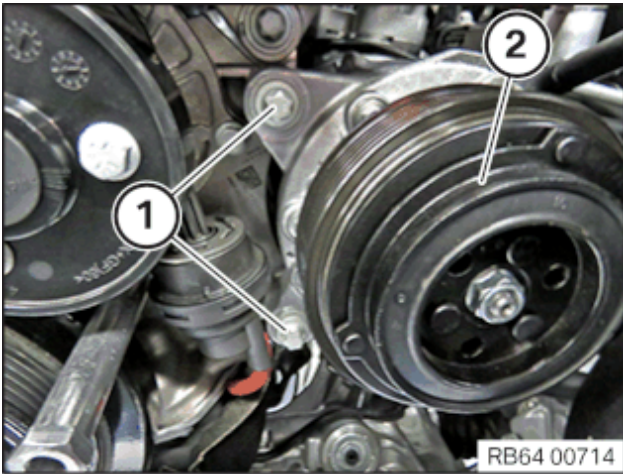

- Loosen screws (1).
- Guide out and remove the air conditioning compressor (2) with wires.

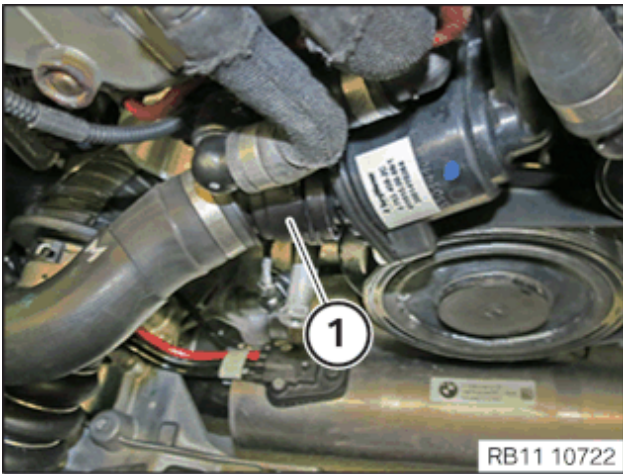

**i** Collect and dispose of emerging fluids. Observe country-specific waste disposal regulations.

- Unlock and pull off the coolant hose (1) on the coolant thermostat.

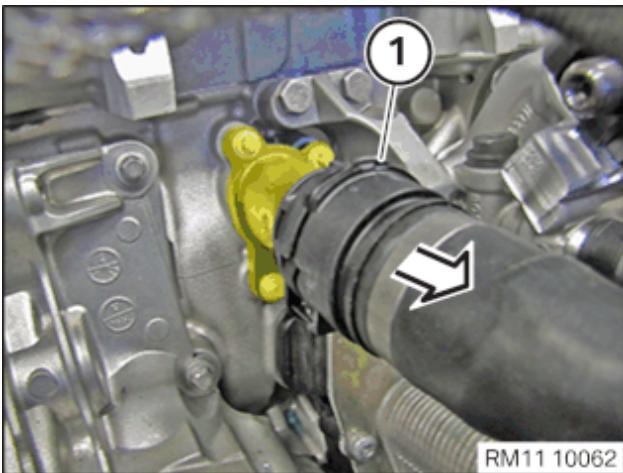

- Unlock the coolant hose (1) under the intake plenum.
- Pull off and remove the coolant hose (1).

## 8 – Removing starter motor

### Prerequisite

Battery earth leads are disconnected.



**Hot surfaces.**

**Risk of burning!**

- Perform all work only on components that have cooled down.



**Working on 12 V vehicle electrical system.**

**Risk of short circuits! Risk of fire!**

- Make sure that **no charger** is connected to the jump start support point in the engine compartment.
- Detach battery earth lead from battery.
- With auxiliary batteries: Detach all battery earth leads from additional batteries.

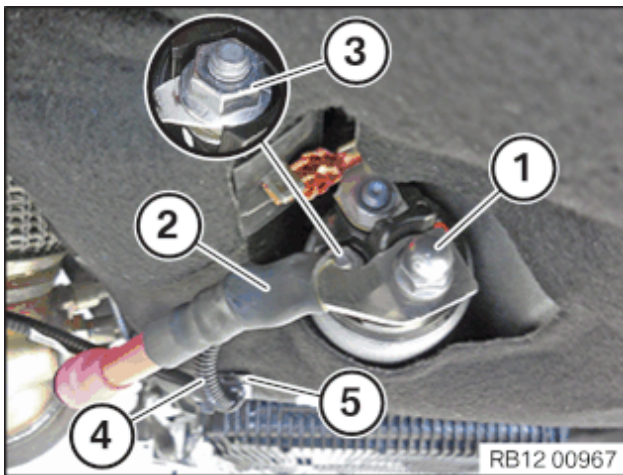

- Loosen nuts (1).
- Thread out positive battery cable (2) and set it aside.
- Loosen nut (3).
- Loosen clip (5).
- Feed out terminal 50 (4) and lay to one side.

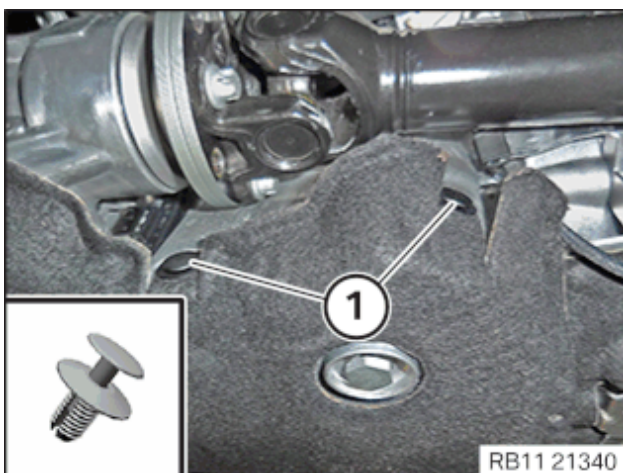

- Loosen the clips (1).

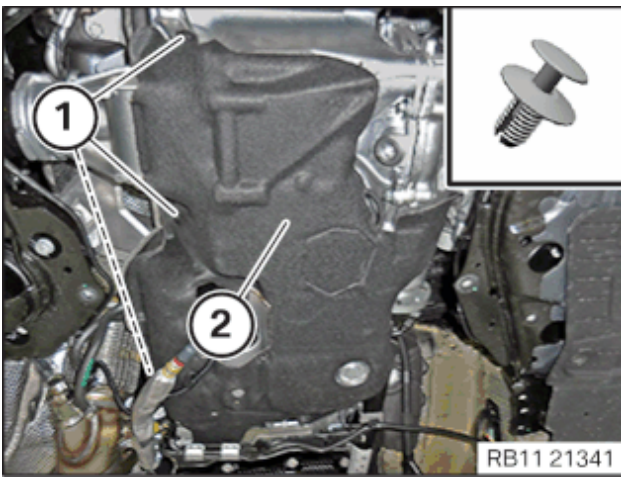

- Loosen the clips (1).
- Remove the acoustic cover (2) of the oil sump.

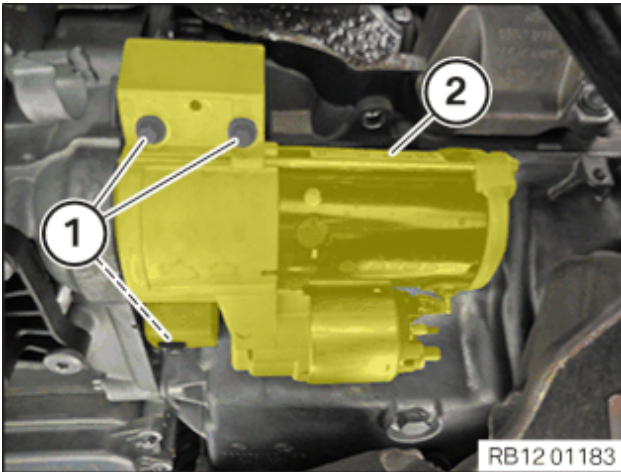

- Loosen screws (1).
- Remove the starter motor (2).

## 9 – Removing the automatic transmission (on mobile lifting table)



**Materials harmful to health.**

**Contact with fluids harmful to health!**

- Note and follow safety information on containers.
- Conduct all work in appropriate personal protective equipment only.



**Damage to the engine block.**

**Serious damage to the engine block and transmission due to damaged and corroded bolts.**

- It is imperative that protruding threads of the transmission bolts are checked for corrosion and damage prior to removal.
- It is imperative that all rust is removed from corroded threads and that they are cleaned prior to removal.
- Renew rusted and damaged bolts.



Collect and dispose of emerging fluids. Observe country-specific waste disposal regulations.

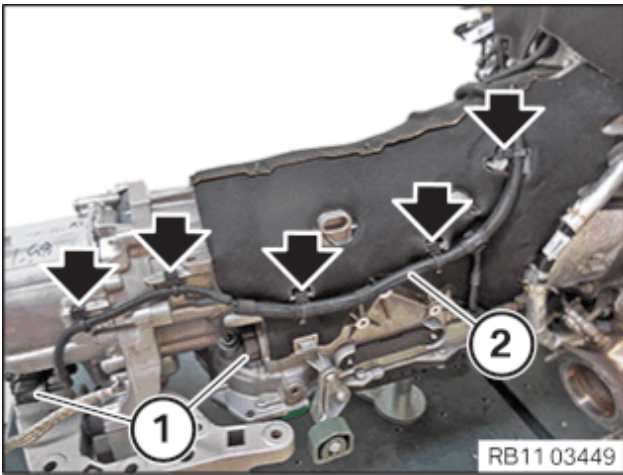

- Unlock and pull off the plug connections (1).
- Release the vehicle wiring harness (2) from the automatic transmission and place aside.

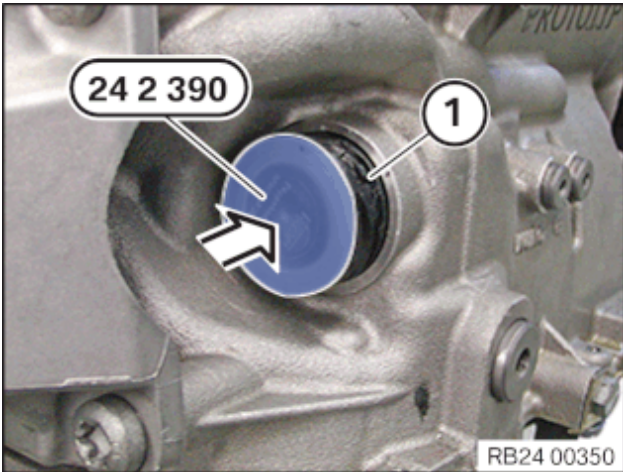

- Insert the special tool **0 494 213 (24 2 390)** into the sealing sleeve (1).

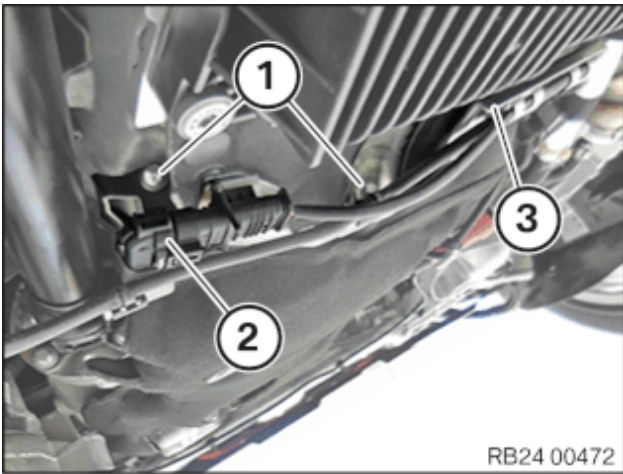

- Loosen screws (1).
- Disconnect the connector (2) .
- Remove holder (3).

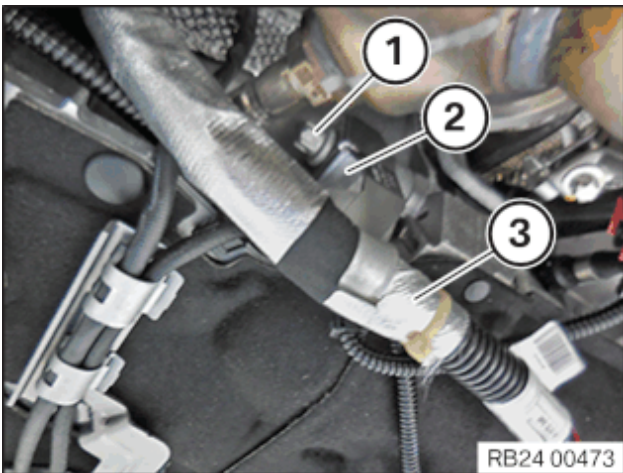

- Detach the line (3) from the holder (2).
- Loosen screw (1).
- Remove holder (2).

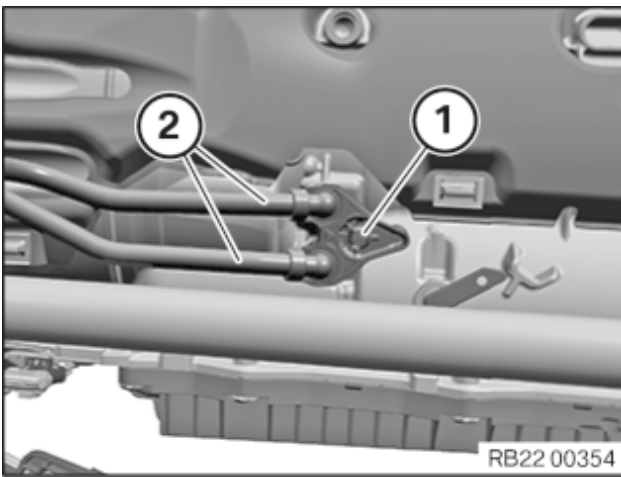

- Loosen screw (1).
- Disconnect hydraulic lines (2) to transmission oil cooler.

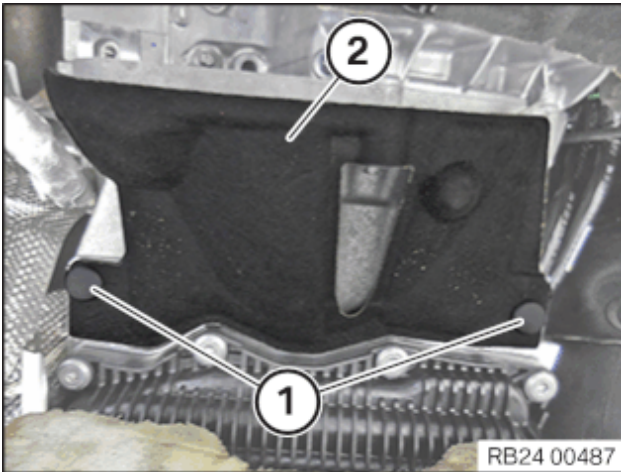

- Remove the expanding rivet (1).
- Remove the acoustic cover (2).

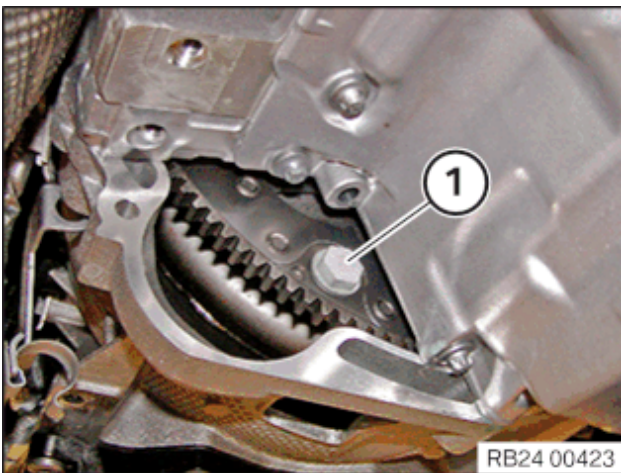

**i**

**Only G05 and G07**

In vehicles with active anti-roll bar (ARS) the fan cowl must be removed in order to spin the engine.

For additional information see: 17 11 035  
Removing and installing/replacing the fan cowl including electric fan

- Turn the engine on the vibration damper with the special tool **0 493 380 (11 6 480)** in the direction of rotation until the bolt (1) becomes visible in the recess.
- Undo all 6 screws (1) on the torque converter.
- Prepare special tool **0 494 478 (24 4 161)** (1) with the shaped element **0 494 622 (24 4 164)** (2) as shown.

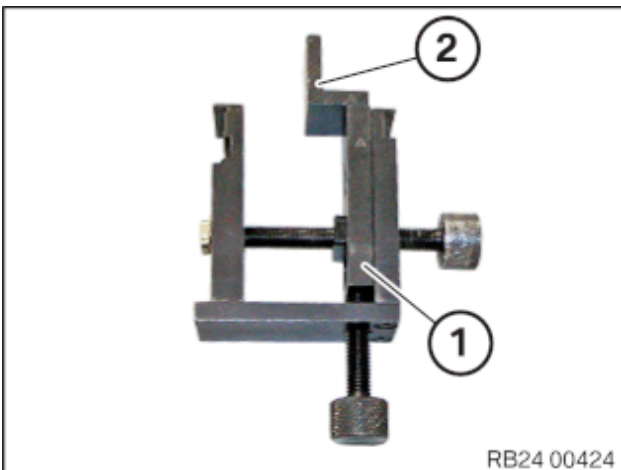

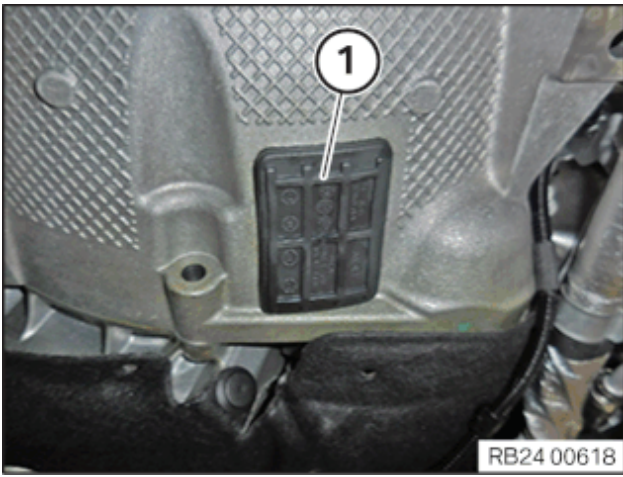

- Remove the sealing cap (1).

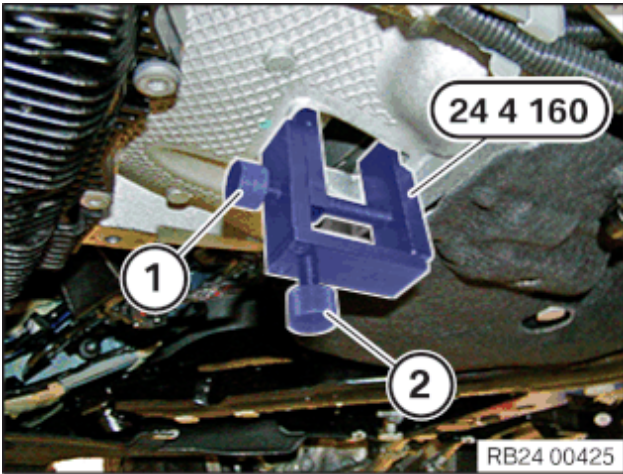

- Insert special tool **0 494 451 (24 4 160)** into the recess of the transmission housing and apply slight tension using the screw (1).
- Screw the bolt (2) in to the stop.
- Tighten down screw (1).

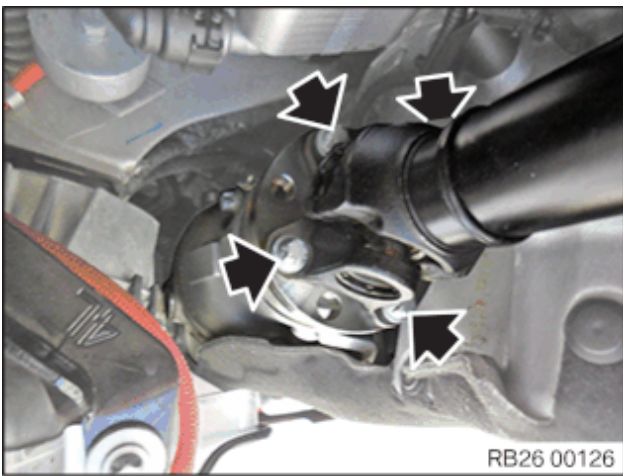

- Remove screws (arrows).
- Secure the propeller shaft on the transmission with a strap.

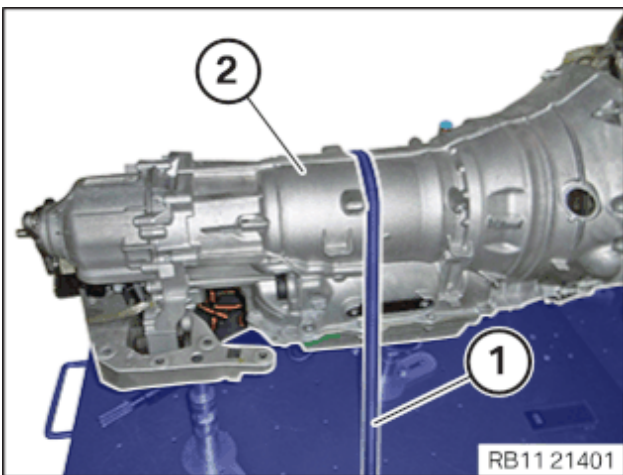

- Lash gearbox with standard tensioning strap (1).

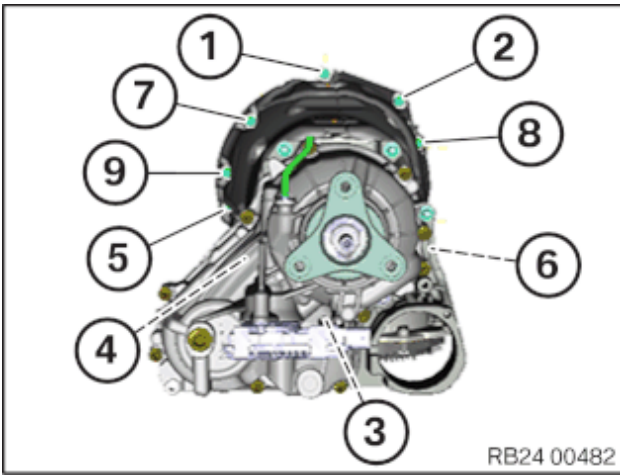

- Support engine.
- Release remaining screws.

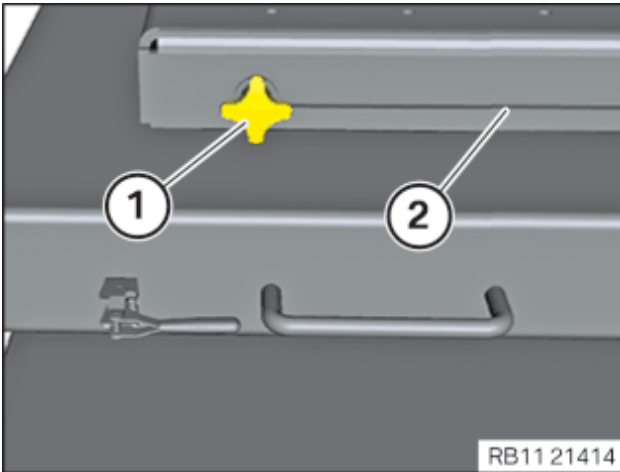

- Loosen retaining screws (1) on the lift table (2) a few threads on both sides.

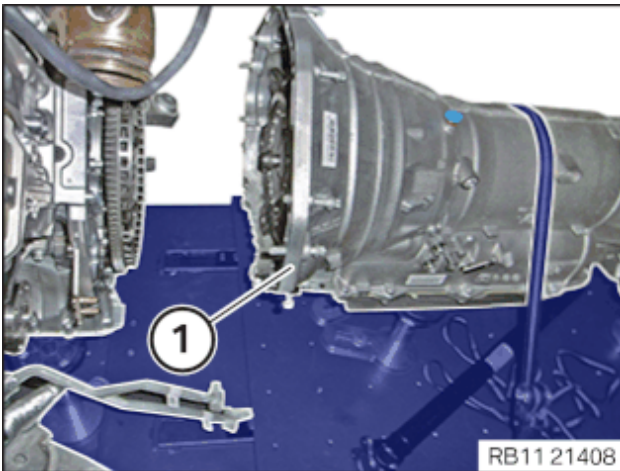

- Disconnect the automatic transmission (1) by moving the panels away from engine.

### 10 – Releasing the vacuum hose from the engine mount

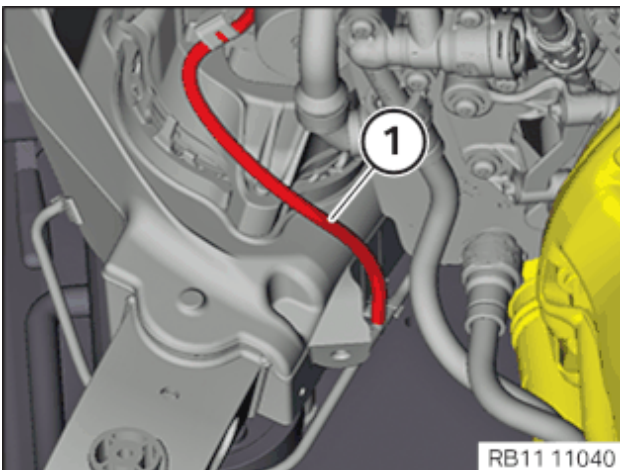

- Pull the vacuum hose (1) from the engine mount.

### 11 – Release the engine mounting bracket on the engine mounts on the left and right

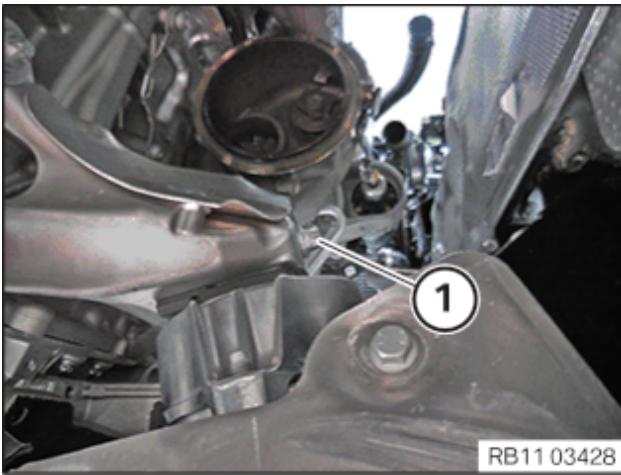

- Release the screw (1) on the engine mounting bracket on the right from below.

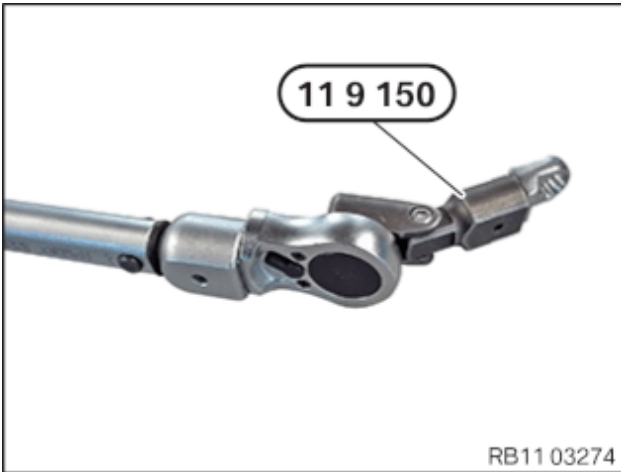

- Prepare special tool as shown.

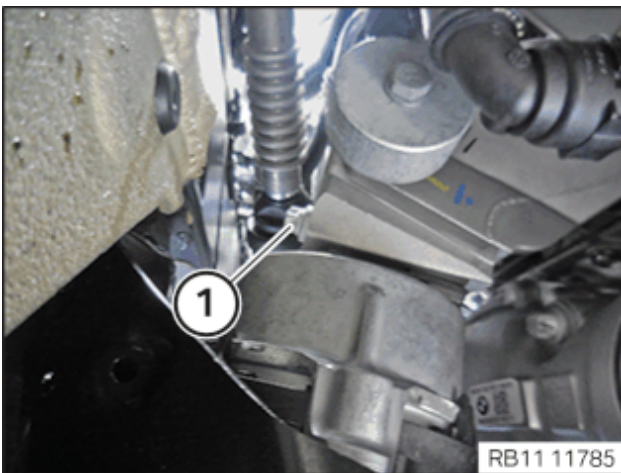

- Loosen the screw (1) on the left engine mounting bracket to the left with the special tool from below.

## MAIN WORK

### 12 – Attach the engine on the workshop crane



**Components connected to the engine joint or cross member.**

#### **Danger of injury!**

- Check lifting eyes and engine mounting brackets for damage, e.g. cracks.
- Attach the component to correctly mounted engine joints or cross members only.
- Exclusively lift the component, do not move it forwards, backwards or in transverse direction.



- Stage the workshop crane **2 220 718**.

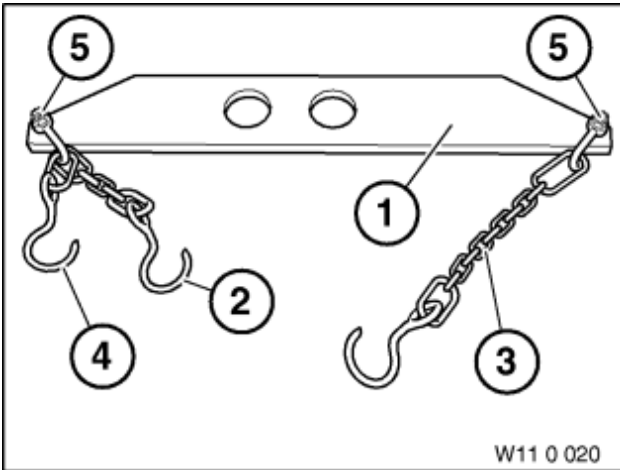

- Stage the lifting gear .

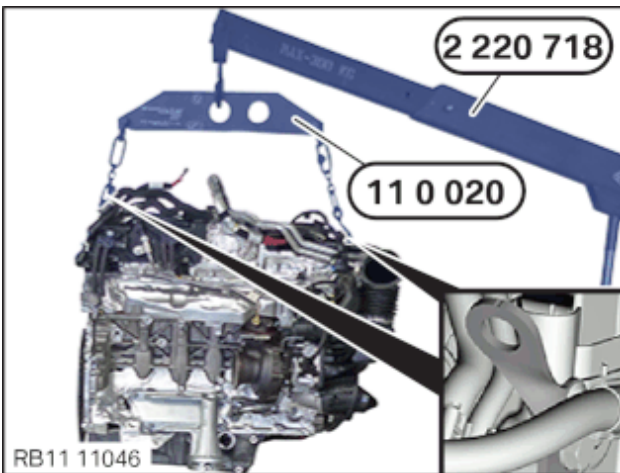

The workshop crane, lifting gear and the mounting brackets on the engine must all be connected to each other so that the engine hangs straight upon lifting.

- Connect both hooks of the special tool to the front and back of the engine with the mounting brackets.
- Connect the workshop crane **2 220 718** to the special tool .
- Raise and remove the engine.

### 13 – Remove bearing support

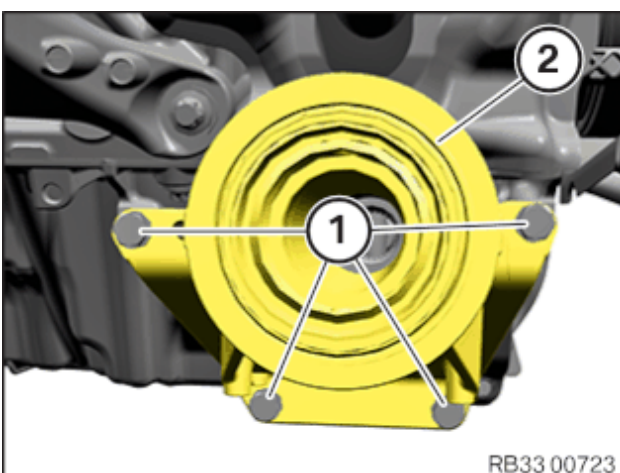

- Loosen screws (1).
- Remove the bearing support (2).

## 14 – Install the engine on the assembly stand



**Heavy component.**

**Heavy components can lead to injury or damage.**

- Remove and install heavy components with the aid of another person/other persons.

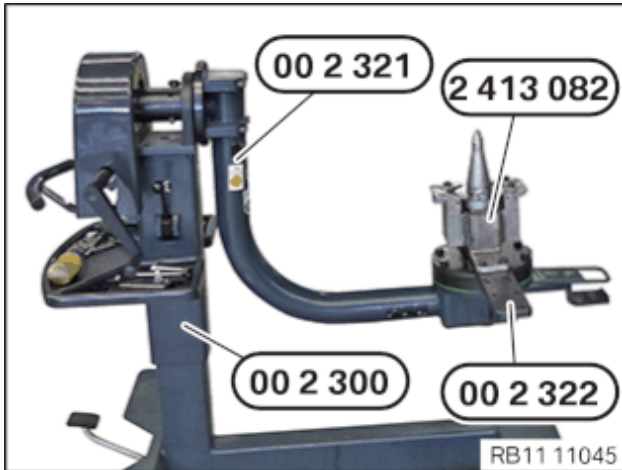

- Install special tool on special tool **0 495 187 (00 2 300)**.

### Engine support arm on the assembly stand

M14 x 95	Tightening torque	130 Nm
----------	-------------------	--------

- Install special tool on special tool .
- Install special tool **2 413 082** on special tool .

### Engine fixture to engine fixture

M10	Tightening torque	100 Nm
-----	-------------------	--------

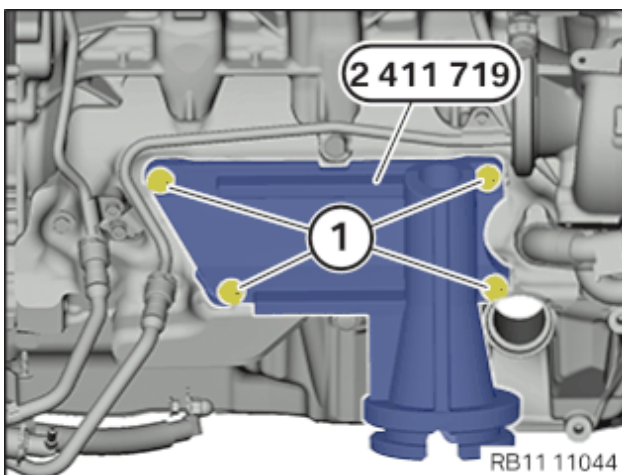

- Tighten special tool **2 411 719** with the screws (1) on the crankcase.

### Engine mounting bracket on engine

M10	Tightening torque	38 Nm
-----	-------------------	-------

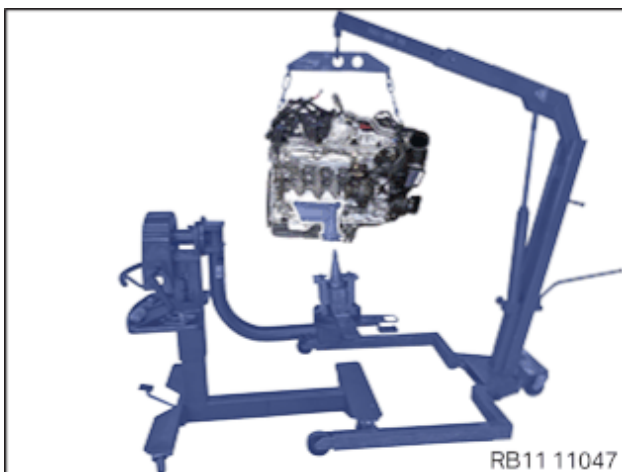

- Lower the engine slowly.

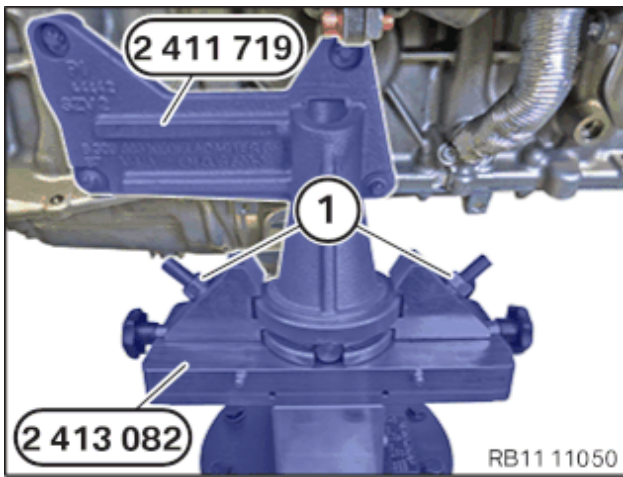

- Make sure special tool **2 411 719** engages with special tool **2 413 082**.
- Tighten the nuts (1) until the clamping jaws are completely flush.

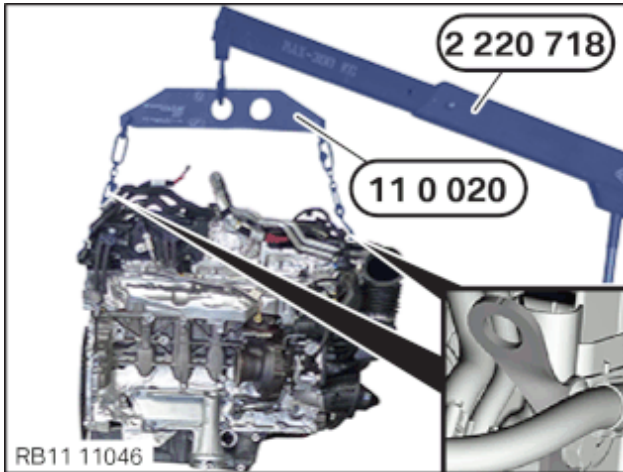

- Release both hooks of the special tool at the front and back of the engine from the mounting brackets.

## 15 – Remove engine from assembly stand



Conduct the following operation with the assistance of a second person.

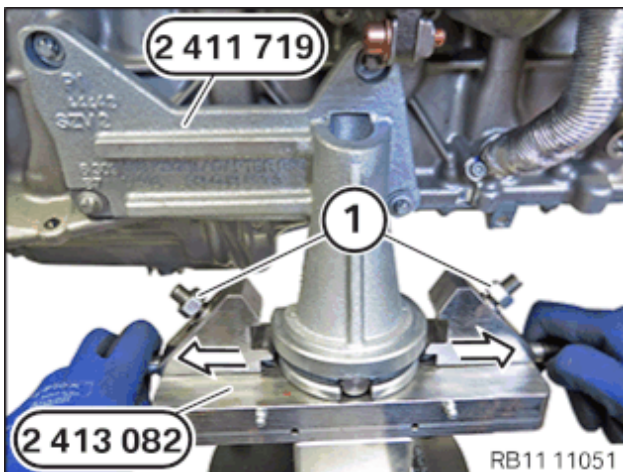

- Slacken nuts (1).
- Unclamp the clamp jaws of the special tool **2 413 082** in the direction of arrow.

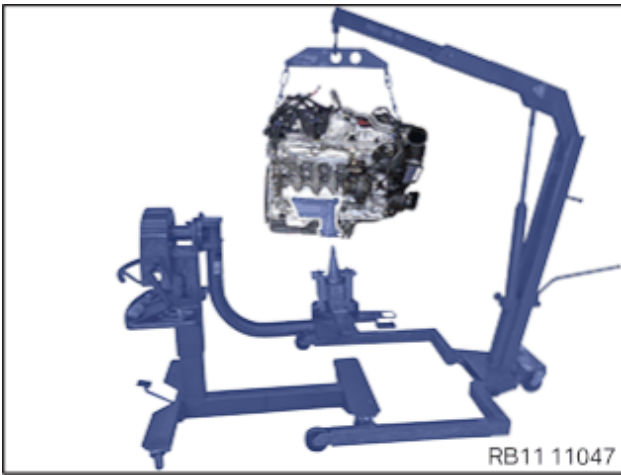

- Raise the engine slowly.

## 16 – Install bearing support

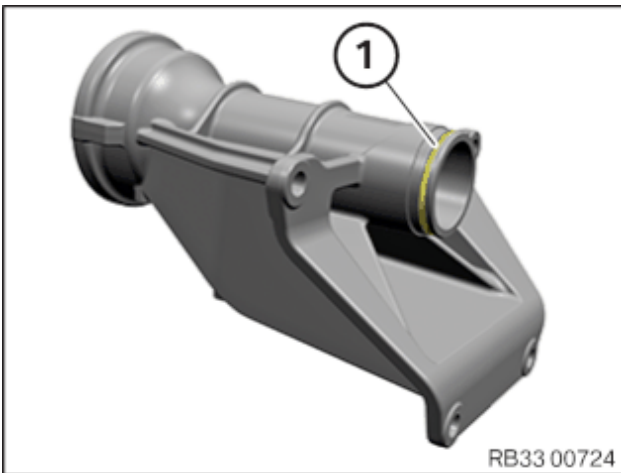

- Check sealing ring (1), replace if necessary.
- Coat the sealing ring (1) with front axle differential oil.

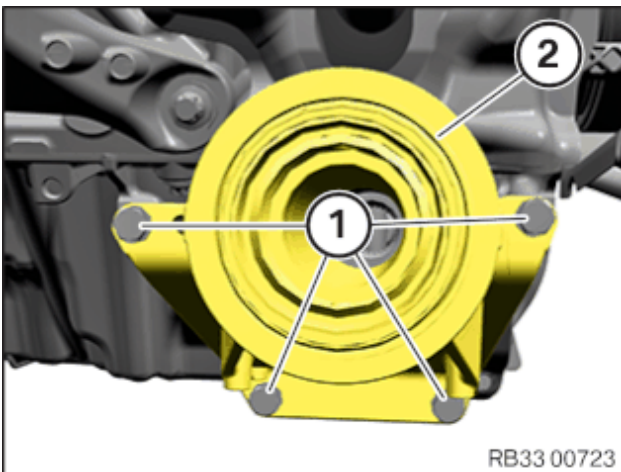

- Position the bearing support (2) at the engine oil sump.
- Tighten the screws (1).

### Bearing support to oil sump

M8	Tightening torque	19 Nm
----	-------------------	-------

## POSTPROCESSES

### 17 – Securing the engine mounting bracket on the left and right engine mounts



In order to prevent play, lower the engine completely before screwing the engine mount and engine mounting bracket.

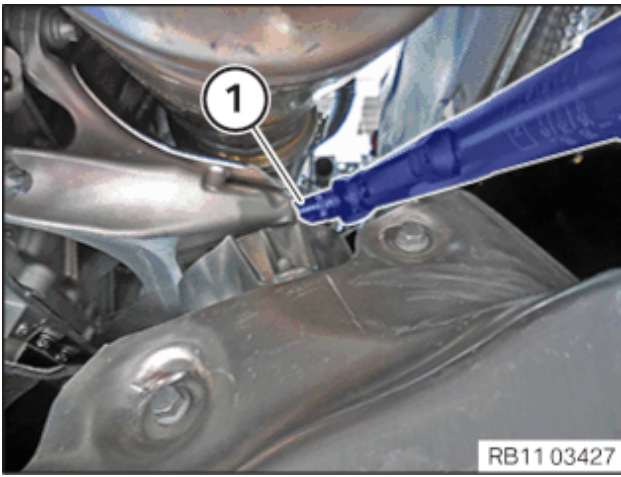

- Tighten the bolt (1) on the right engine mounting bracket from the bottom.

#### Engine support bracket to engine mount

M12x1.5x40	Tightening torque	100 Nm
------------	-------------------	--------

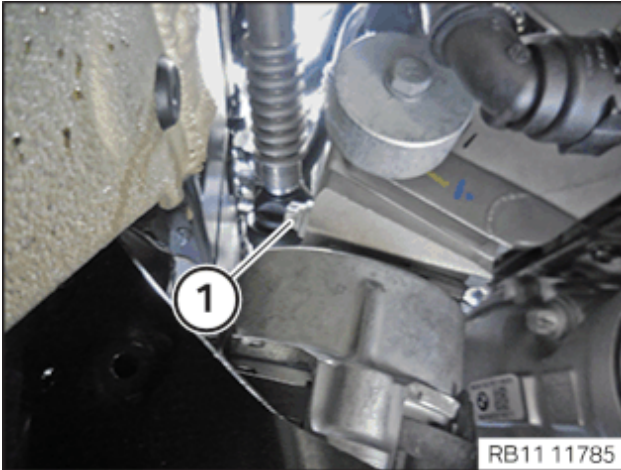

- Tighten screw (1) on left engine mounting bracket using special tool from the bottom.

#### Engine support bracket to engine mount

M12x1.5x40	Tightening torque	100 Nm
------------	-------------------	--------

### 18 – Fastening vacuum hose on engine mount

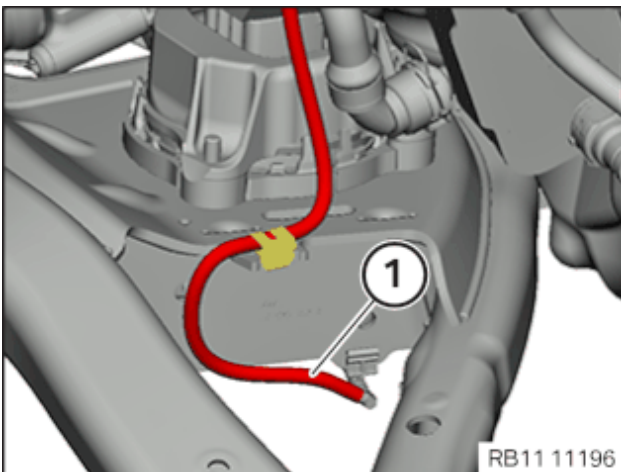

- Connect vacuum hose (1) to engine mount.
- Clip in the vacuum hose in the marked area.

### 19 – Installing the automatic transmission (on mobile lifting table)



**Damage to the transmission.**

**Damage to the transmission by unapproved transmission oil.**

- Use only the approved transmission oil.
- Check the transmission oil level after completing the repair.

## ► Checking mounting orientation of torque converter

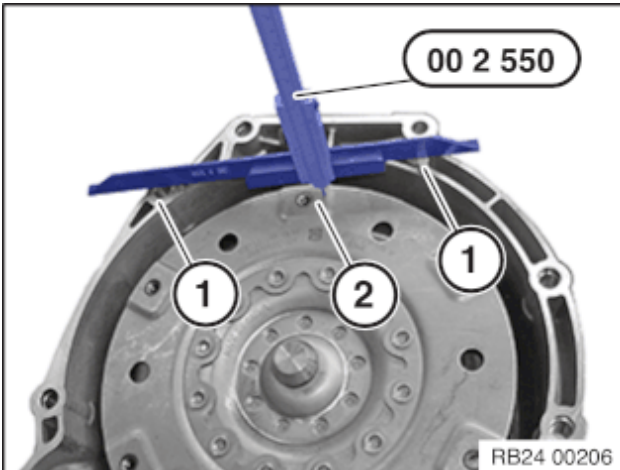

**Damage to the automatic transmission/impeller.**

**When disconnecting the engine and transmission, the torque converter can become loose! Failure to observe the correct installation positions of the torque converter may lead to damage to the impeller driver.**

- Make sure that the torque converter is in the correct installation position before installing the automatic transmission.

- Check the installation dimension between the contact surfaces (1) and the outer edge (2) of the torque converter threaded hole using special tool **0 490 189 (00 2 550)**.

See repair instructions

Remove and install/replace torque converter ()

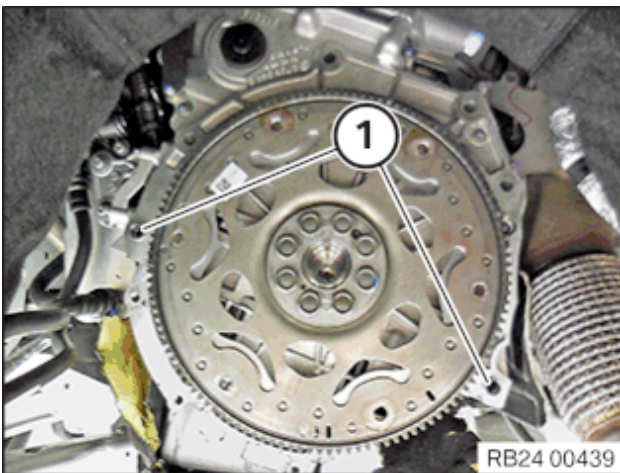

- Check the fitting sleeves (1) for correct fit and damage and renew as needed.

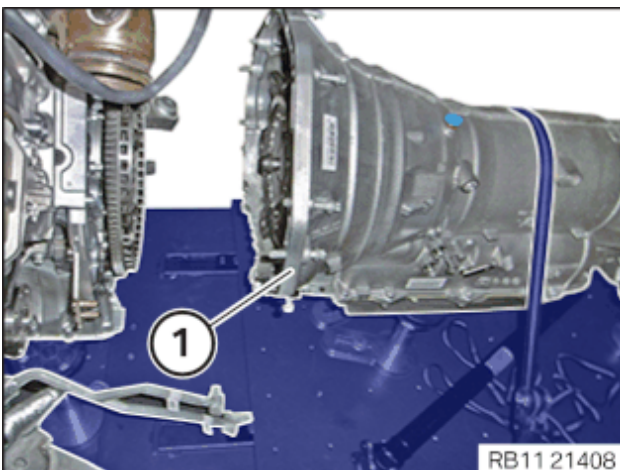

- Feed in automatic transmission (1) by moving the panels on the engine and install.

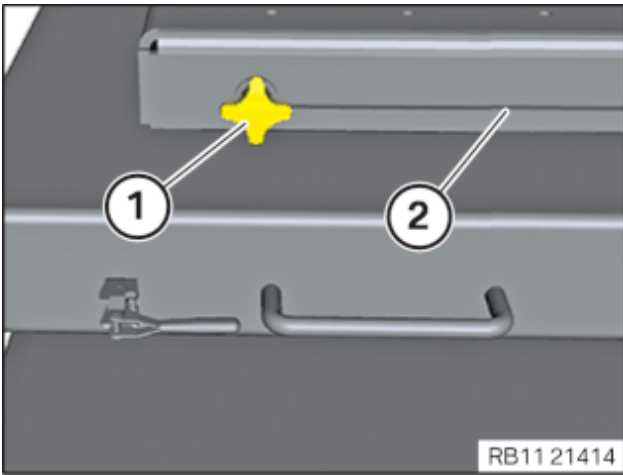

- Hand-tighten retaining screws (1) on both sides on the lift table (2).

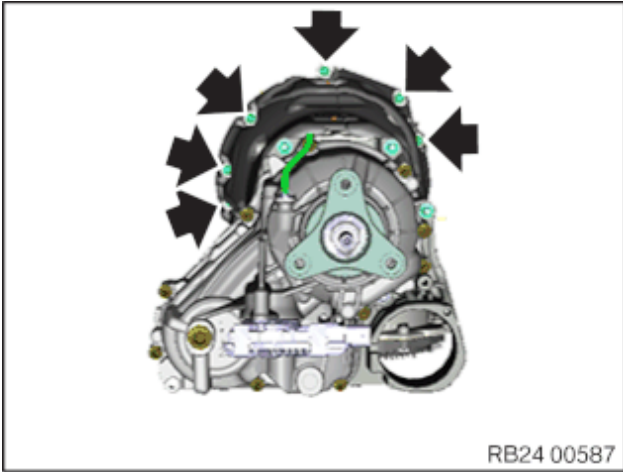

- Flange-mount the transmission with the transfer box (VTG) and front propeller shaft.
- Turn torque converter until bore hole of torque converter is aligned with bore hole of flywheel.
- Fit the transmission bolts (arrows) and apply hand-tight.

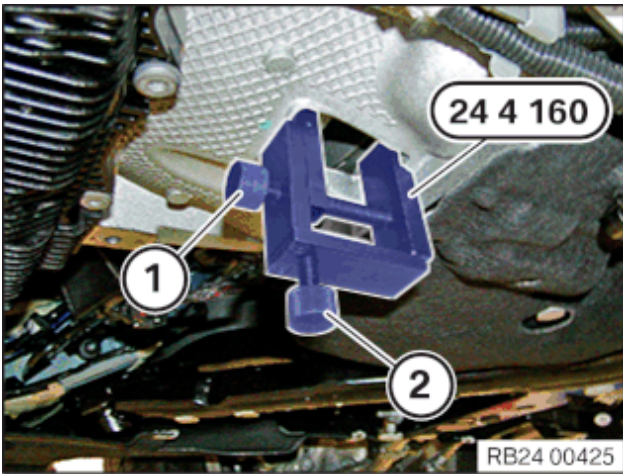

- Release screw (1) and screw (2).
- Remove special tool **0 494 451 (24 4 160)**.

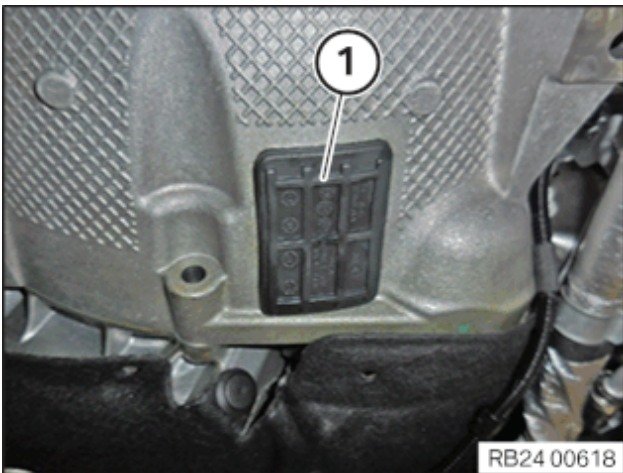

- Install the sealing cap (1).

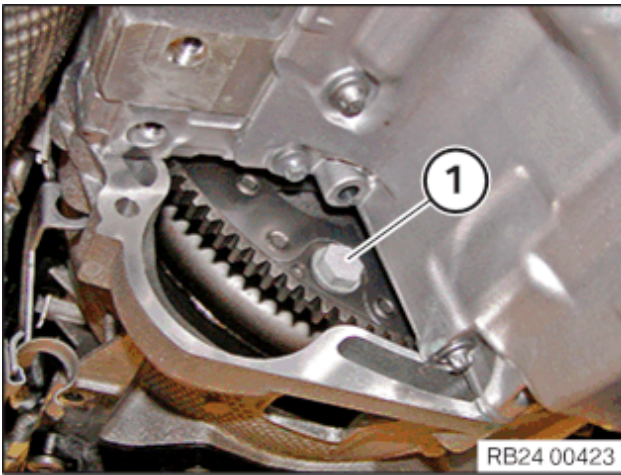

- Renew screws.

**Parts:** Screws

- Crank the engine on the vibration damper in the direction of rotation using special tool **0 493 380 (11 6 480)** to tighten all six screws (1).
- Tighten all 6 screws (1) of the torque converter using special tool **0 491 667 (24 1 110)**.

**Torque converter to flywheel**

M10	Renew screws.	Tightening torque	56 Nm
-----	---------------	-------------------	-------

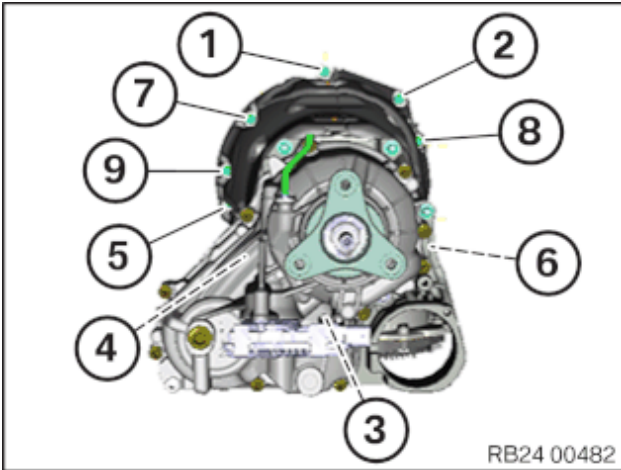

- Tighten the transmission bolts in sequence (1) to (9).

**Transmission to engine**

M8		Tightening torque	19 Nm
M12		Tightening torque	66 Nm

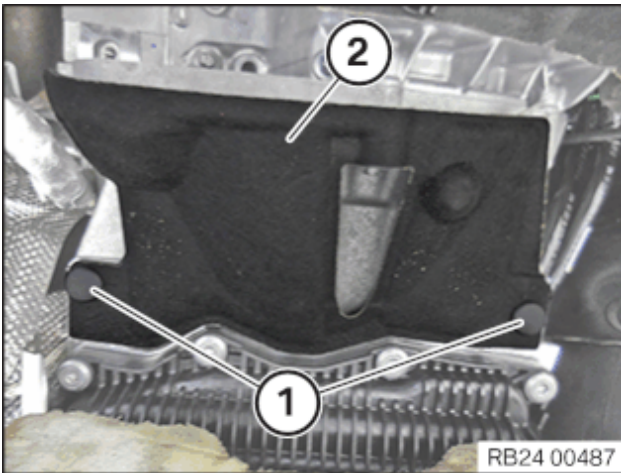

- Install acoustic cover (2).
- Install the expanding rivet (1).

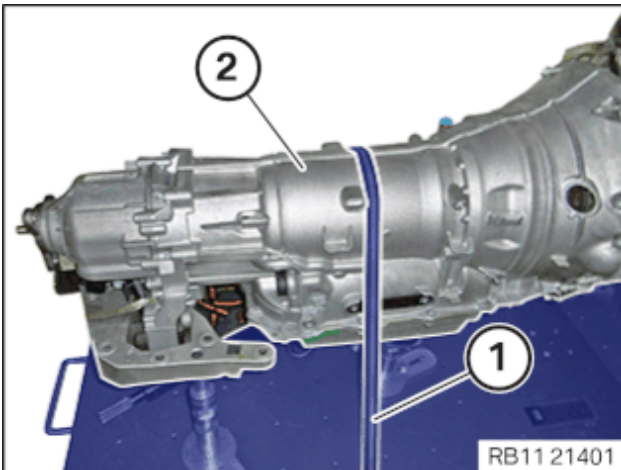

- Remove tensioning strap (1).

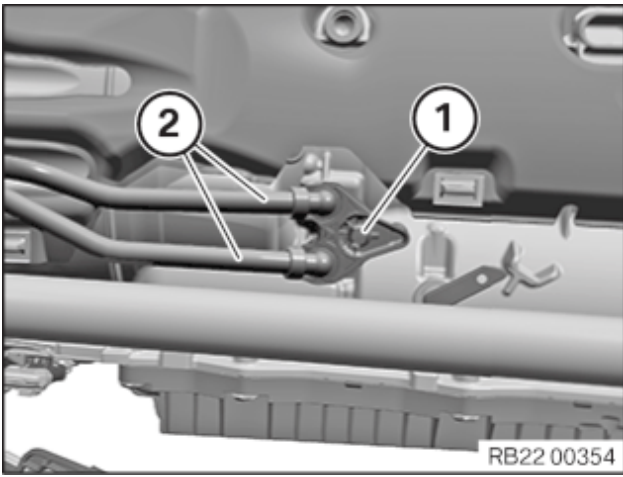

- Renew sealing rings.
- **Parts:** Sealing ring
- Install hydraulic lines (2) on transmission.
- Position and tighten the screw (1).

**Transmission oil line to transmission**

M6x25	Renew the sealing ring.	Tightening torque	8 Nm
-------	-------------------------	-------------------	------

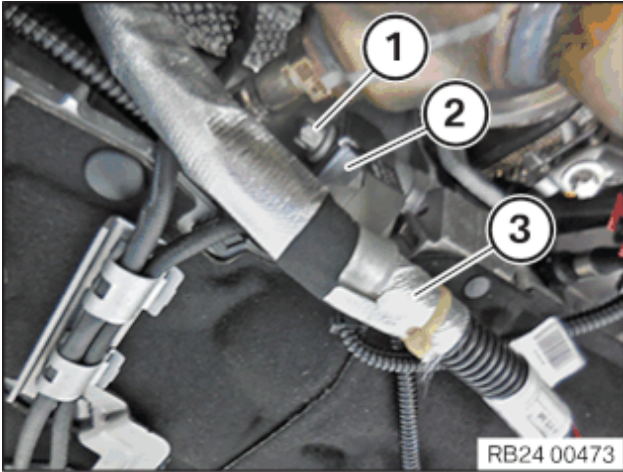

- Install holder (2).
- Position the screw (1) and hand-tighten.
- Clip in line (3) to holder (2).

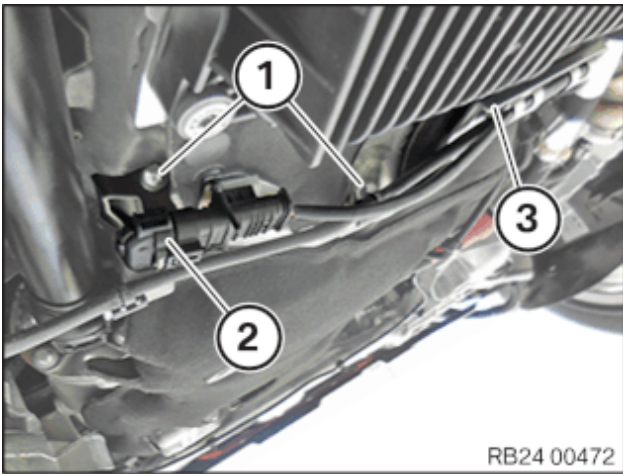

- Install holder (3).
- Connect connectors (2) and lock.
- Position the screws (1) and hand-tighten.

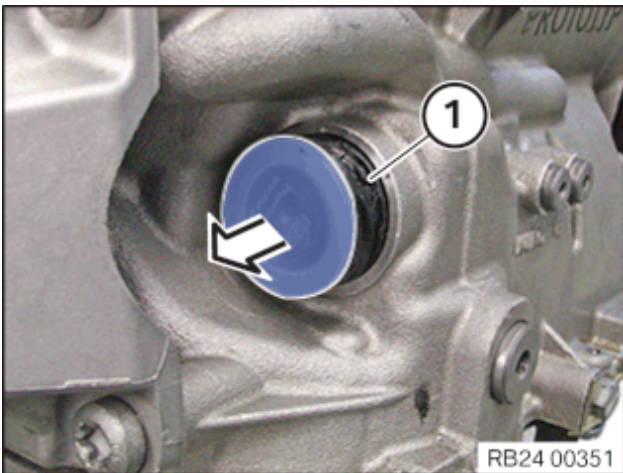

- Remove the special tool **0 494 213 (24 2 390)** from the sealing sleeve (1).

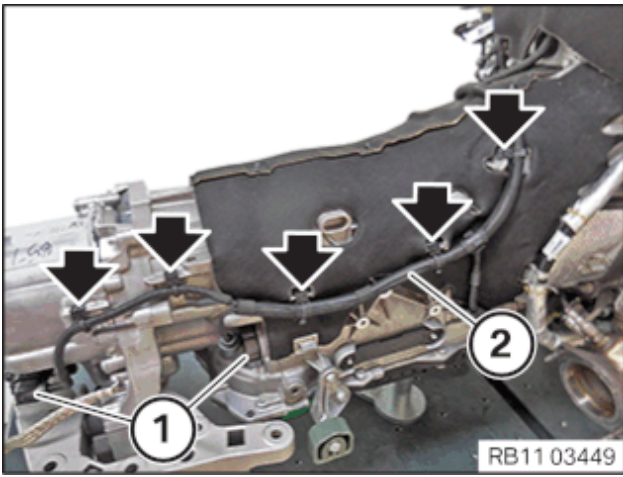

- Route and secure the wiring harness (2).
- Connect and lock the connector (1).  
The locks must engage audibly.

## 20 – Installing starter motor

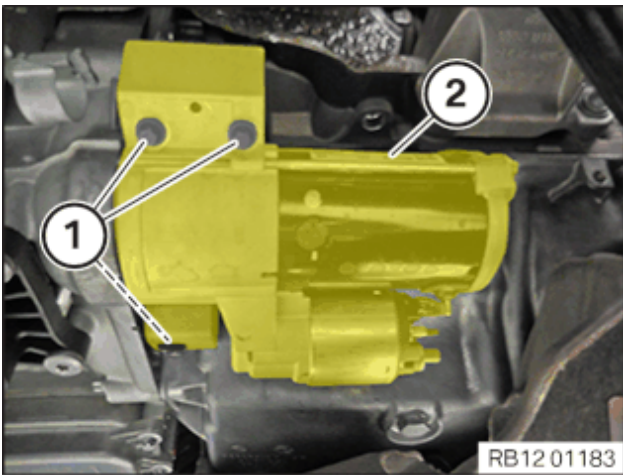

- Insert and install the starter motor (2).
- Tighten the screws (1).

### Starter motor to crankcase

M8x60	Tightening torque	19 Nm
-------	-------------------	-------

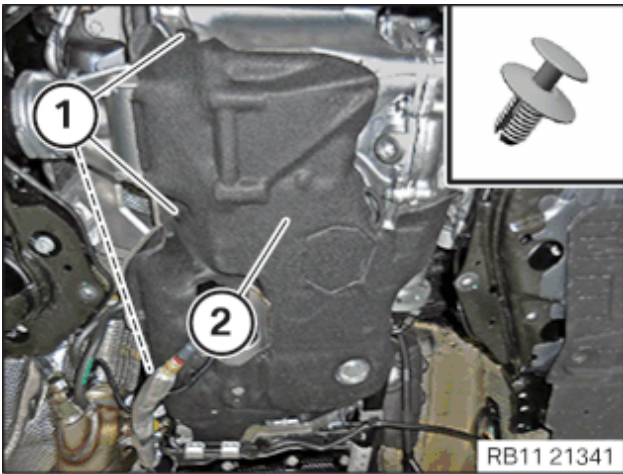

- Position the acoustic cover (2) of the oil sump.
- Mount clips (1).

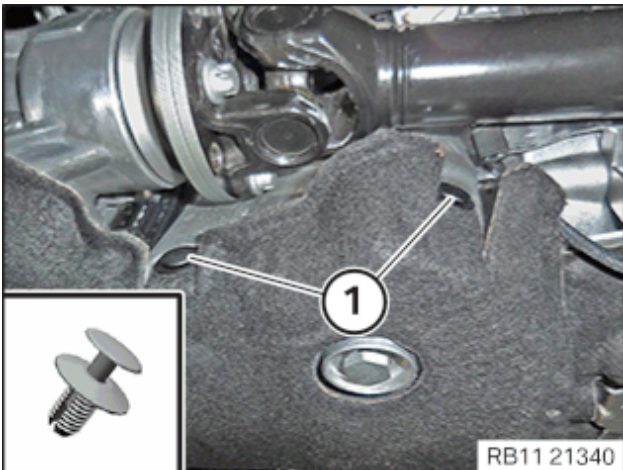

- Mount clips (1).

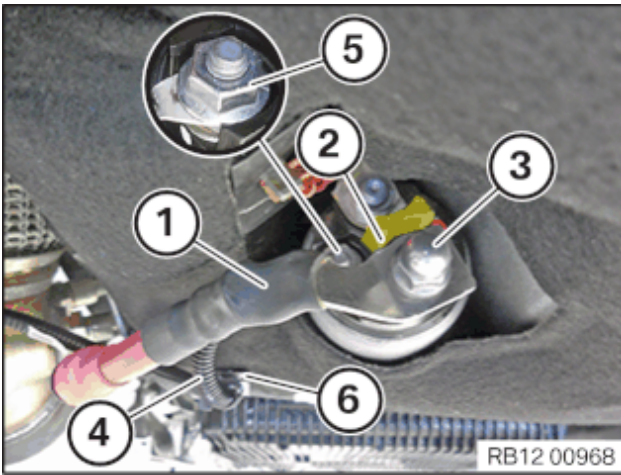

- Insert and install terminal 50 (4).
- Tighten nut (5).

#### Terminal 50 to starter motor

M6	Tightening torque	7,5 Nm
----	-------------------	--------

- Insert and install the positive battery cable (1).
- Attach the positive battery cable (1) to the anti-twist lock (2).
- Tighten nut (3).

#### Battery positive lead to starter

M8	Tightening torque	13,5 Nm
----	-------------------	---------

- Mount the clip (6).

## 21 – Attaching assemblies (engine removed)

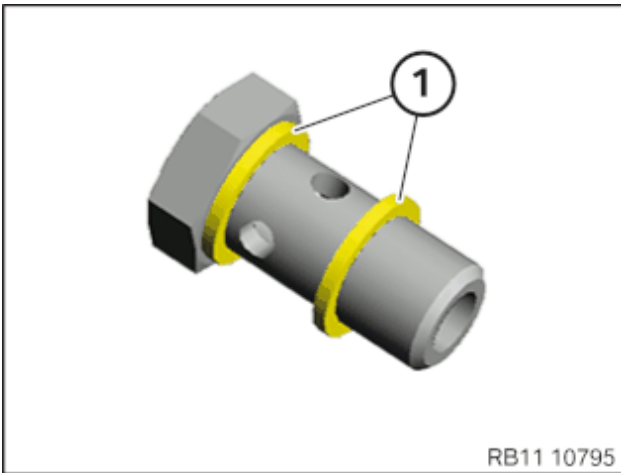

- Renew sealing rings (1) of banjo bolt.
- Parts:** Sealing rings.

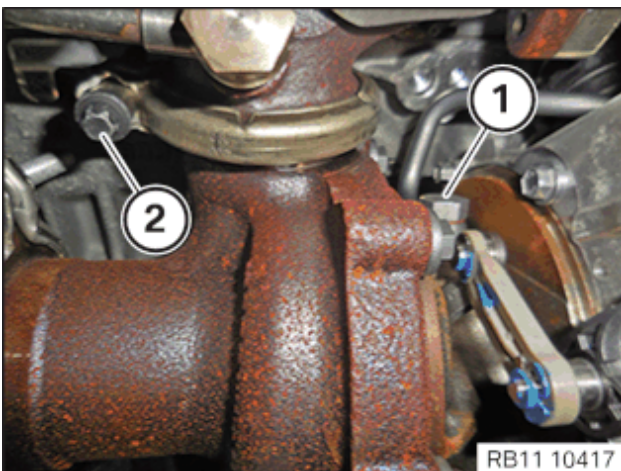

- Insert and install the exhaust turbocharger .
  - Install new V-clip with new seal.
- Parts:** Seal, V-clip
- Tighten down screw (2).

#### Exhaust turbocharger to exhaust manifold

Clamp	Tighten until both shanks of the clamp are together.	Tightening torque	19 Nm
-------	--	-------------------	-------

- Tighten the banjo bolt (1).

#### Oil feed line to exhaust turbocharger

Banjo bolt M10x19	Renew gaskets!	Tightening torque	10 Nm
		Angle of rotation	45 °

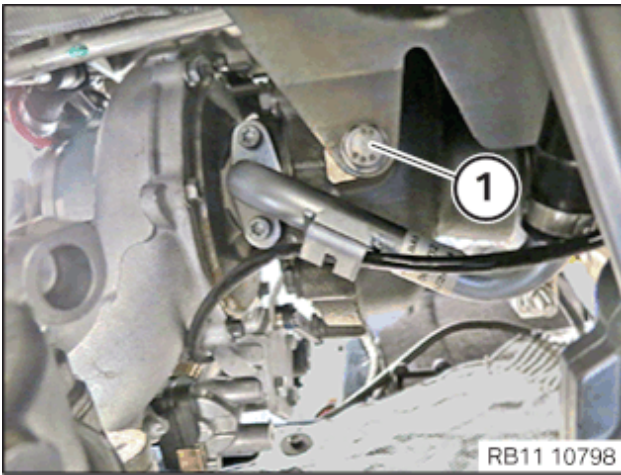

- Tighten down screw (1).

### Exhaust turbocharger to panel holder for support to crankcase

Hexagon screw M8x16	Tightening torque	22 Nm
------------------------	-------------------	-------

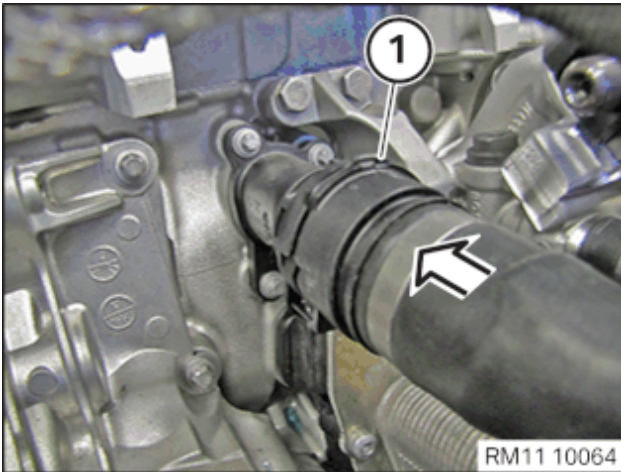

- Connect coolant hose (1) at connecting branch and lock.
- Lock must snap audibly into place.

### ► Prepare for the installation of the air conditioning compressor

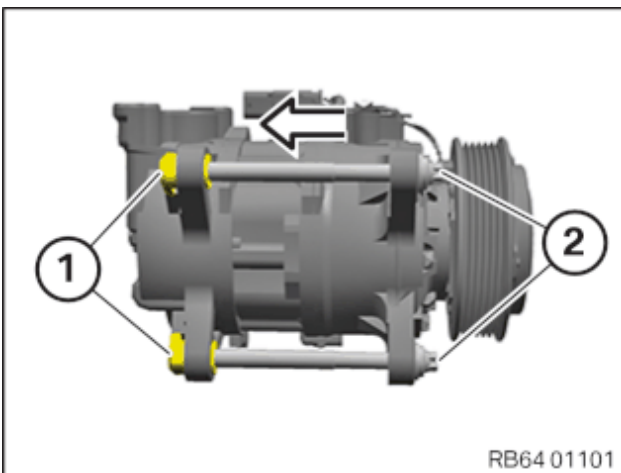

- Screw the screws (2) in the threaded support sleeves (1).
- Slightly press back the threaded support sleeves (1) with the help of screws (2) in the direction of arrow.
- Screw the screws (2) out of the threaded support sleeves (1) once again.

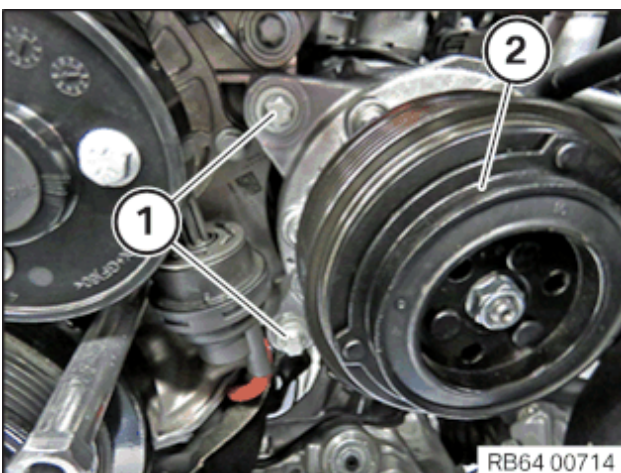

- Feed in air conditioning compressor (2) with lines and position.
- Tighten the screws (1).

### Air conditioning compressor in component carrier

M10	Tightening torque	38 Nm
-----	-------------------	-------

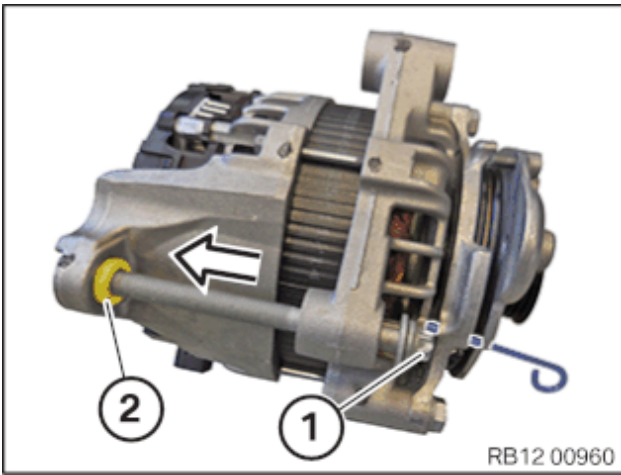

- To facilitate installation of alternator, push threaded support sleeves (2) back slightly.
- Screw the screw 1 into threaded support sleeve.
- Press back the threaded support sleeve (2) using the bolt (1).
- Once again unscrew the screw (1) from the threaded support sleeve .

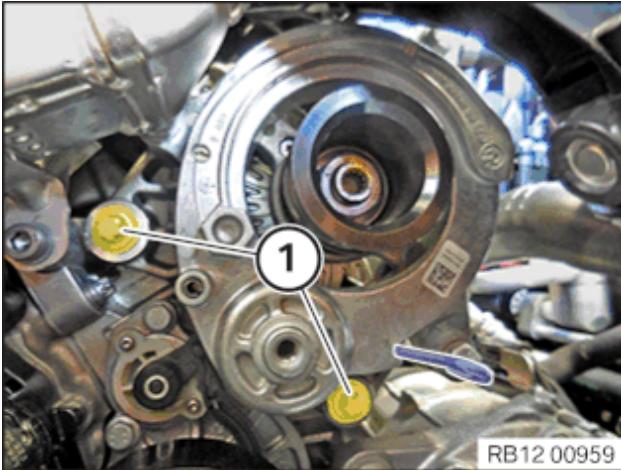

- Insert and position the alternator .
- Tighten the screws (1).

#### Alternator to component carrier

M10x75	Tightening torque	38 Nm
M10x125	Tightening torque	38 Nm
M10x90	Tightening torque	38 Nm

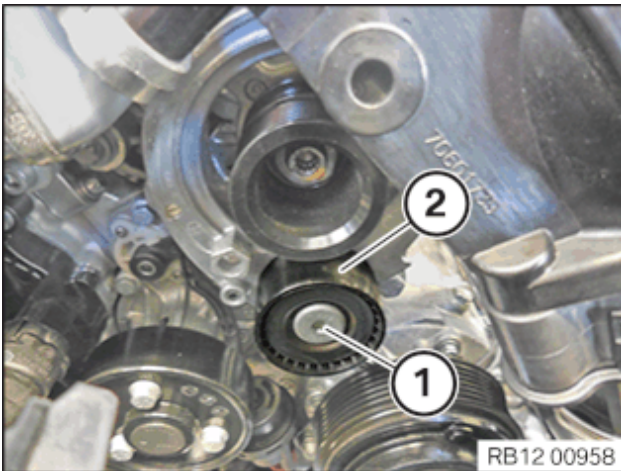

- Insert and install the deflecting element (2).
- Tighten the screws (1).

#### Deflecting element to belt tensioner

M8	Tightening torque	28 Nm
----	-------------------	-------

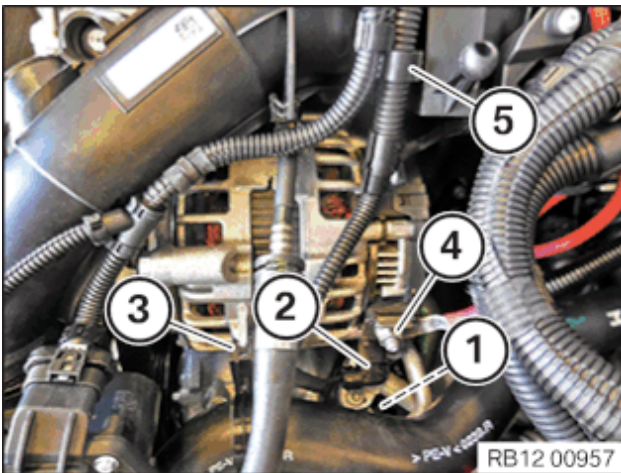

- Connect and lock the clamp (5).
- Tighten nut (4).

#### Positive battery cable to the alternator

M8	Tightening torque	19 Nm
----	-------------------	-------

- Secure the holder (3).
- Connect connector 2 at alternator and lock.
- Connect and lock the connector (1) on the air conditioning compressor.

All connectors must audibly engage.

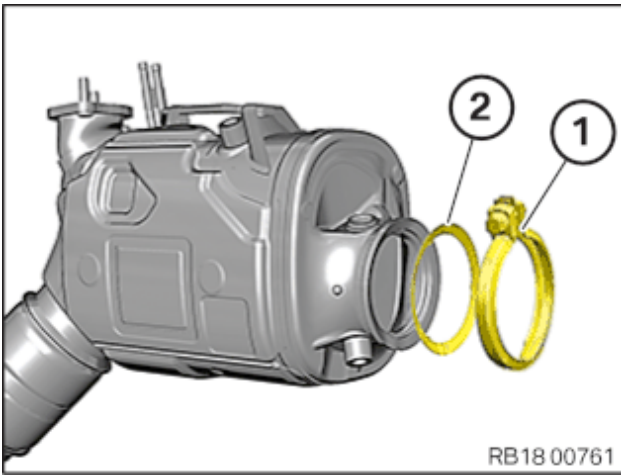

RB18 00761

- Renew the V-clip (1).
- Renew the gasket (2).

**Parts:** V-band clamp

**Parts:** Gasket

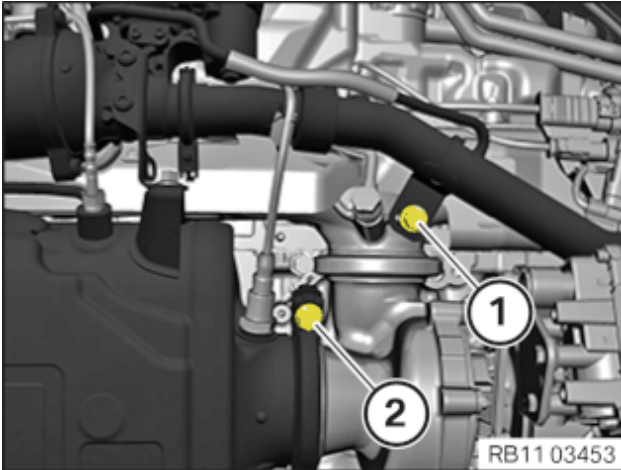

RB11 03453

- Insert and position the diesel particulate filter.



- Note the installation position of the component. The component may be installed in various installation positions.

- Install V-clip and tighten screw (2).

#### Exhaust turbocharger to diesel particulate filter

Clamp	If necessary, renew clamp.	Tightening torque	13 Nm
-------	----------------------------	-------------------	-------

- Tighten down screw (1).

#### Exhaust-gas recirculation pipe for low-pressure exhaust-gas recirculation to exhaust manifold

M8		Tightening torque	19 Nm
----	--	-------------------	-------

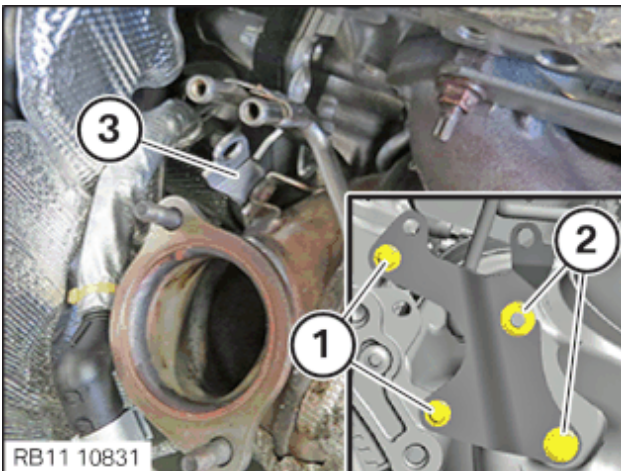

RB11 10831

- Install the sheet metal bracket (3) of the diesel particulate filter on the cylinder head.
- Tighten the screws (1).

#### Metal holder for diesel particulate filter to crankcase

M8x16		Tightening torque	19 Nm
-------	--	-------------------	-------

- Tighten the screw (2) and the nut (2).

#### Diesel particulate filter to crankcase holder

M8		Tightening torque	19 Nm
----	--	-------------------	-------

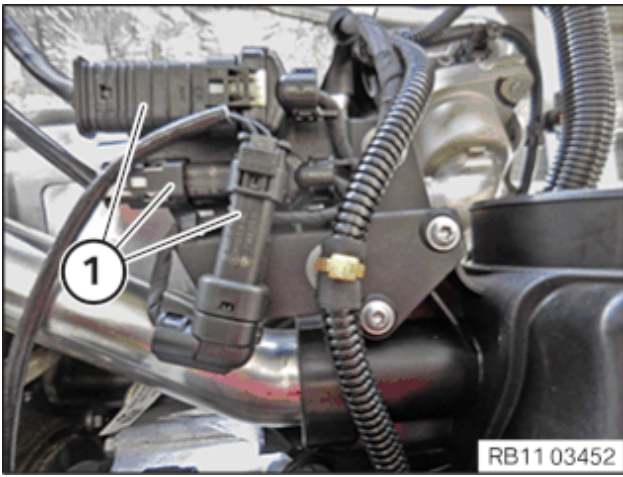

- Connect connectors (1) and lock.  
Lock must audibly engage.

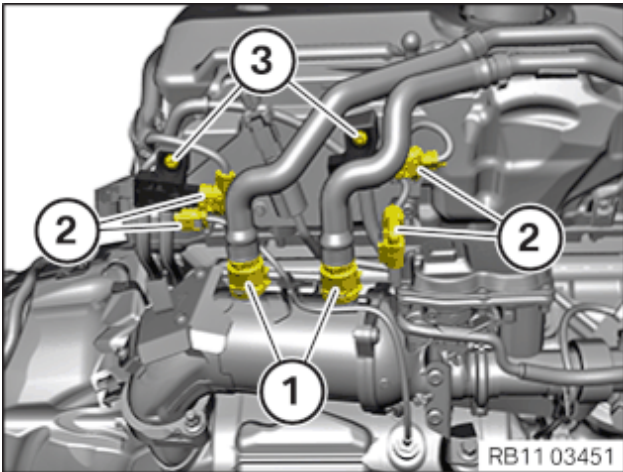

- Guide in and install the differential pressure sensors.
- Tighten the screws (3).

**Differential pressure sensor of diesel particulate filter on cylinder head cover**

TS5x20	Tightening torque	4 Nm
--------	-------------------	------

**Differential pressure sensor for low-pressure exhaust-gas recirculation**

TS5x20	Tightening torque	4 Nm
--------	-------------------	------

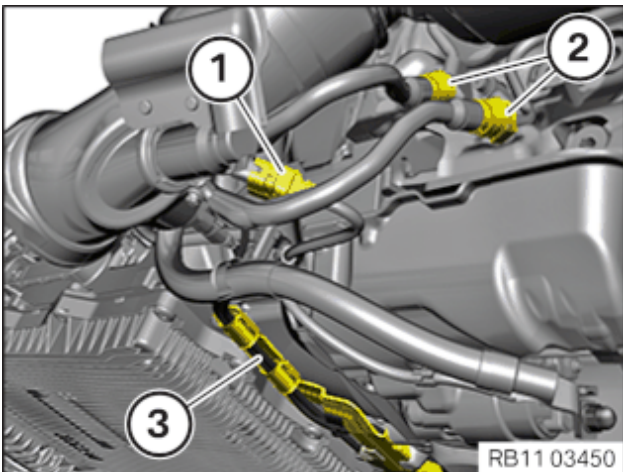

- Connect connectors (2) and lock.  
Lock must audibly engage.
- Connect connectors (1) and lock.  
Lock must audibly engage.
- Connect the coolant hoses (2) and lock.  
Lock must audibly engage.
- Secure the vehicle wiring harness bracket in the holder (3).

**23 – Install bottom clean air pipe**

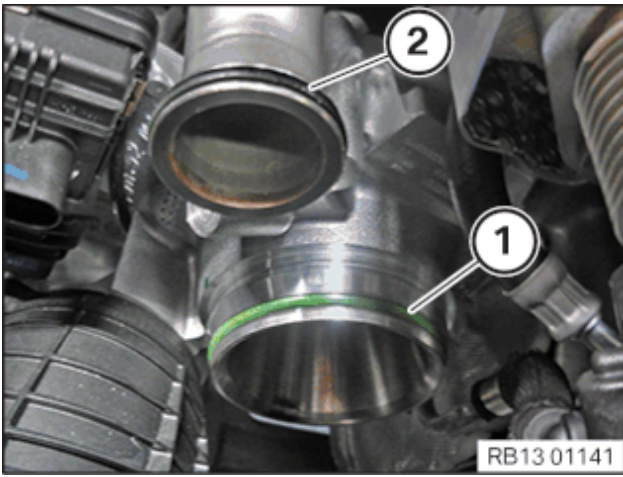

- Renew sealing rings (1) and (2).

**Parts:** Sealing ring

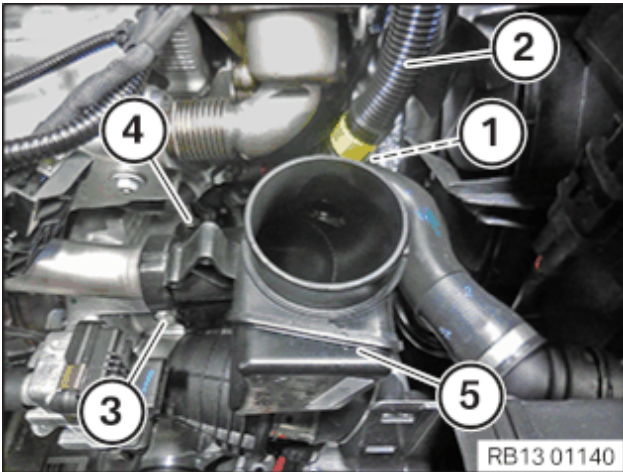

- Feed in lower clean air pipe (5) and install.
- Connect and lock the clamp (4).  
The clamp (4) must engage audibly.
- Renew the screw (3).

**Parts:** Screw

- Tighten down screw (3).

**Lower clean air pipe to exhaust turbocharger**

M6x20	Renew screw.	Tightening torque	8 Nm
-------	--------------	-------------------	------

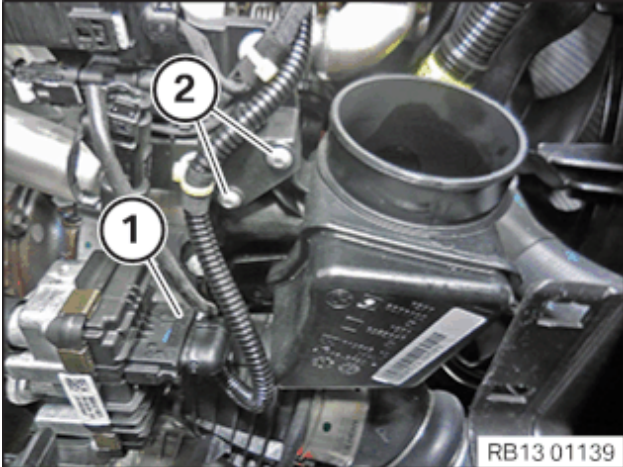

- Connect line (2) and lock the lock (1).
- Connect connectors (1) and lock.  
The connector (1) must engage audibly.
- Tighten down screws (2).

**Cable clip to clean air pipe**

TS5x20		Tightening torque	4 Nm
--------	--	-------------------	------

**24 – Installing acoustic cover at rear**

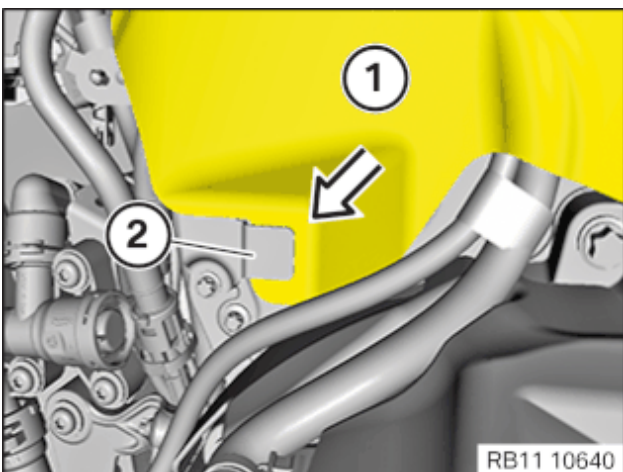

- Position the acoustic cover (1) in the rear.
- Insert the acoustic cover (1) to the rear of the engine into the bracket (2) in the direction of the arrow.

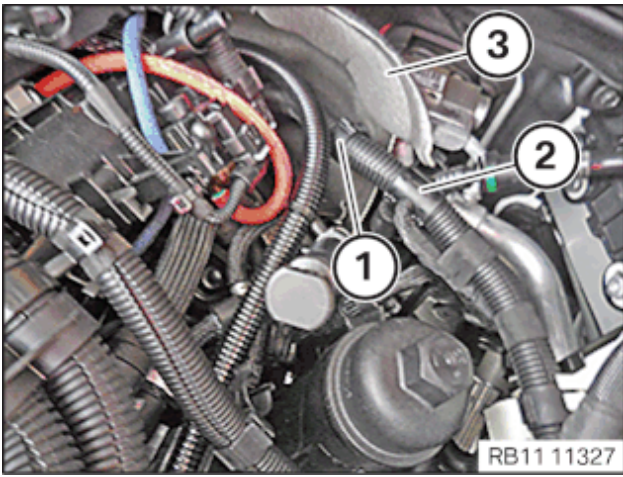

- Position the acoustic cover (3).
- Secure the wiring harness (2) to the clamp (1).

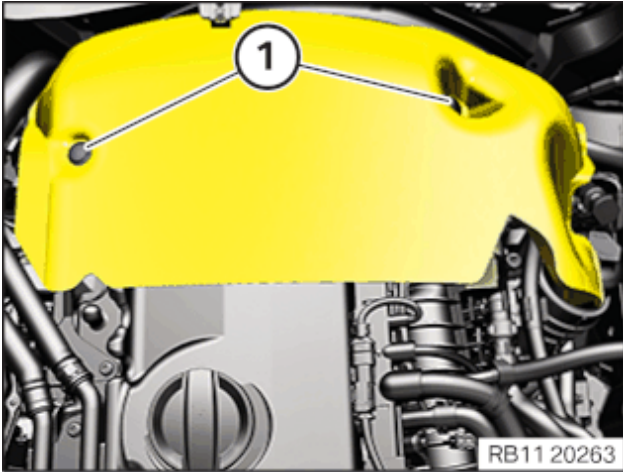

- Secure expanding rivet (1).

## 25 – Install the acoustic cover for the engine at the front

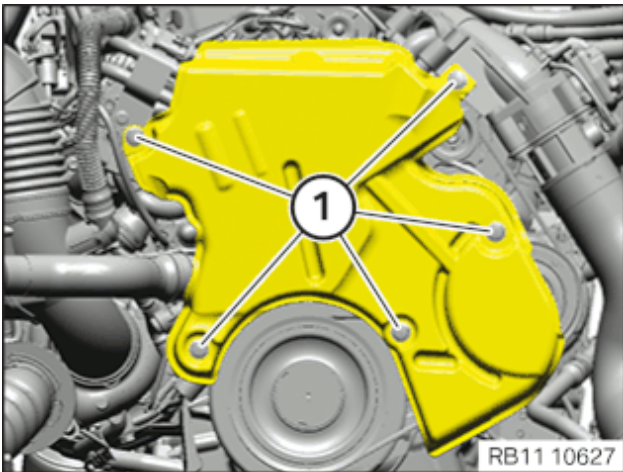

- Position the acoustic cover and secure the expanding rivets (1).

## 26 – Installing the front transmission input shafts (on the mobile lifting table)

**i**

Carry out the following operations with an auxiliary person.



Perform the operations on the left and right side.

**Check**

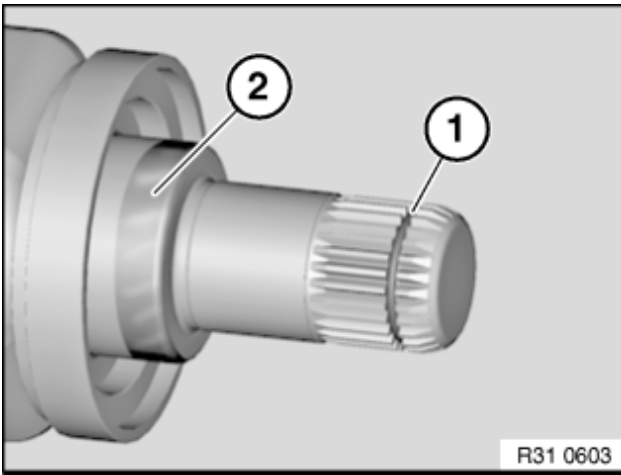

- Renew the circlip (1).
- Parts:** Circlip
- Coat the contact surface (2) of the output shaft with the approved front axle transmission oil (see additional information).
  - Check the gearing for damage or deformation.

**Result**

The gearing is deformed or damaged.

**Measure**

- Renew the output shaft.

**Parts:** Output shaft

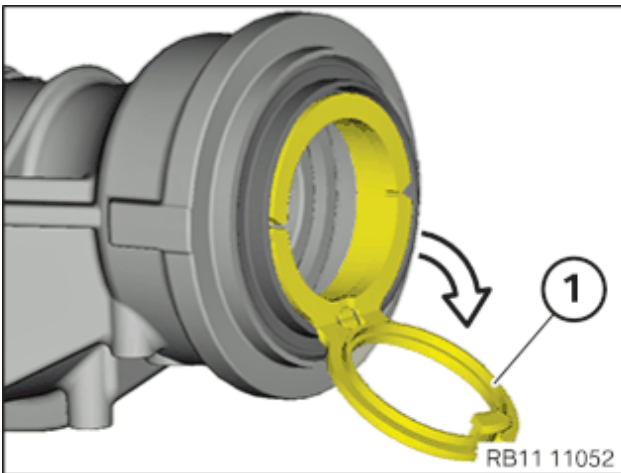

**i** Radial shaft seal ring are equipped with an installation protection ring. The installation protection ring is used to protect the sealing lip when installing the output shaft.

- Open the installation protection ring (1) before the installation of the output shaft in the direction of arrow.

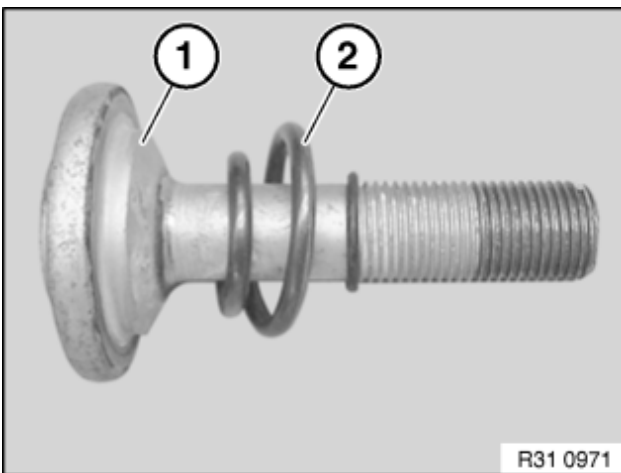

- Renew the screw (1) and the compression spring (2).

**Parts:** Screw, compression spring

- Clean and degrease the screw (1).
- Note the mounting orientation of compression spring (2).

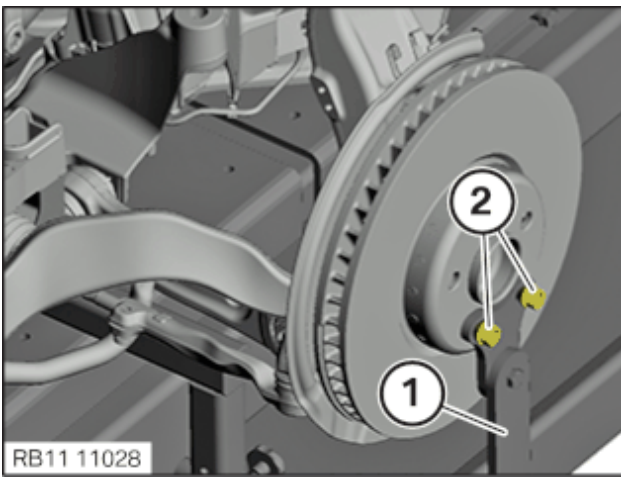

- Hold the swivel bearing with the special tool **2 220 718**.
- Loosen screws (2).
- Remove the fixture (1) of the swivel bearing and set it aside.

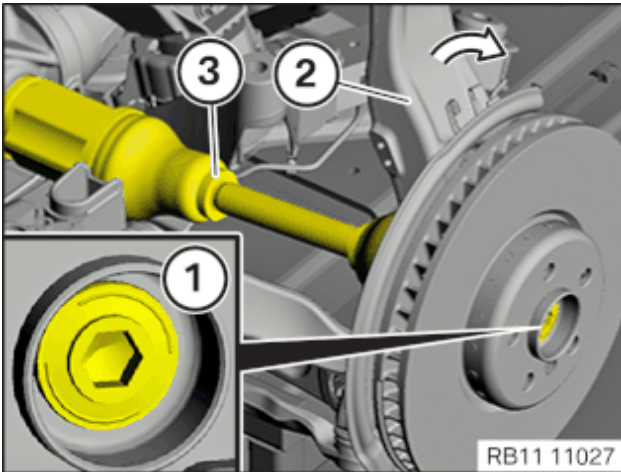

- Tilt the swivel bearing (2) slightly forward in the direction of arrow.
- Insert and install transmission input shaft (3).
- Hand-tighten the collar bolt (1) with the compression spring.

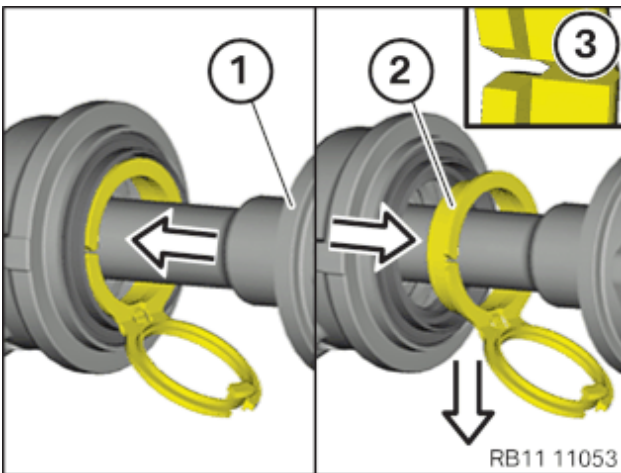

- Loosen the assembly protection ring (2) guide it out a little.
- Pull the installation protection ring (2) downwards in the direction of arrow by applying force until the predetermined breaking points (3) on the installation protection ring break.
- Insert the output shaft (1) into the front axle transmission until the limit position in the direction of arrow and until you can feel the output shaft engaging.

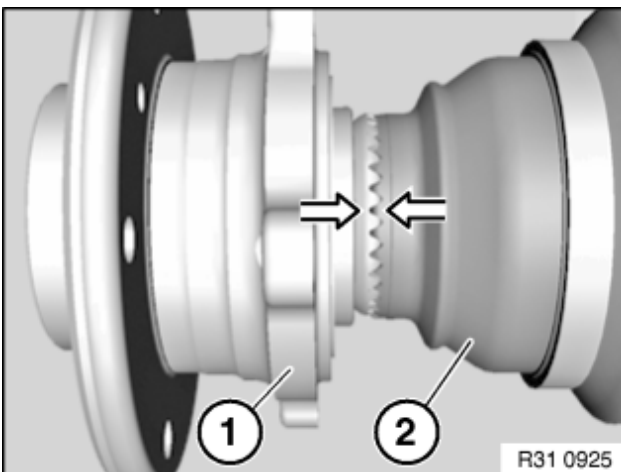

**i** The front gearing of the wheel bearing and output shaft must be installed in an interlocking position (tooth-in-tooth).

- Ensure positive locking by two-way twisting of the wheel bearing (1) and the output shaft (2).

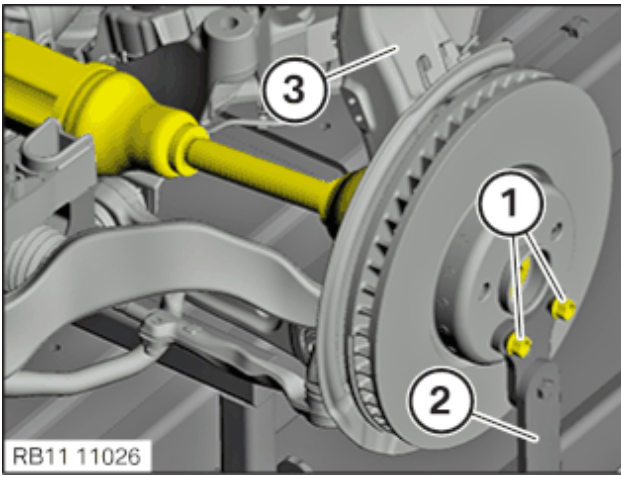

- Install the fixture (1) of the swivel bearing (3).
- Tighten the screws (2).



- Tighten screw (1) with the special tool **0 490 504 (00 9 120)**.

#### Output shaft to wheel bearing

M16	Replace collar bolt and spring.	Jointing torque	210 Nm
		Angle of rotation	90 °

## 27 – Installing the complete front axle including engine and transmission

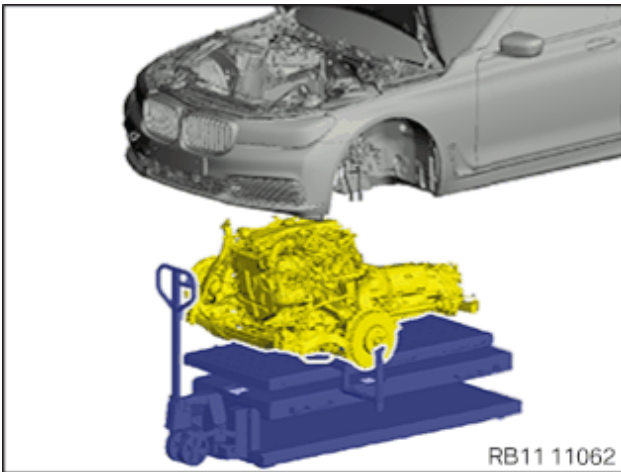

- See additional information.

## Additional Information

### Overview of Tightening Torques

#### Engine support arm on the assembly stand

Used in step [14](#)

M14 x 95

Tightening torque

130 Nm

#### Engine fixture to engine fixture

Used in step [14](#)

M10

Tightening torque

100 Nm

<b>Engine mounting bracket on engine</b>			Used in step <a href="#">14</a>
M10		Tightening torque	38 Nm
<b>Bearing support to oil sump</b>			Used in step <a href="#">16</a>
M8		Tightening torque	19 Nm
<b>Engine support bracket to engine mount</b>			Used in step <a href="#">17</a>
M12x1.5x40		Tightening torque	100 Nm
<b>Torque converter to flywheel</b>			Used in step <a href="#">19</a>
M10	Renew screws.	Tightening torque	56 Nm
<b>Transmission to engine</b>			Used in step <a href="#">19</a>
M8		Tightening torque	19 Nm
M12		Tightening torque	66 Nm
<b>Transmission oil line to transmission</b>			Used in step <a href="#">19</a>
M6x25	Renew the sealing ring.	Tightening torque	8 Nm
<b>Starter motor to crankcase</b>			Used in step <a href="#">20</a>
M8x60		Tightening torque	19 Nm
<b>Terminal 50 to starter motor</b>			Used in step <a href="#">20</a>
M6		Tightening torque	7,5 Nm
<b>Battery positive lead to starter</b>			Used in step <a href="#">20</a>
M8		Tightening torque	13,5 Nm
<b>Exhaust turbocharger to exhaust manifold</b>			Used in step <a href="#">21</a>
Clamp	Tighten until both shanks of the clamp are together.	Tightening torque	19 Nm
<b>Oil feed line to exhaust turbocharger</b>			Used in step <a href="#">21</a>
Banjo bolt M10x19	Renew gaskets!	Tightening torque	10 Nm
		Angle of rotation	45 °
<b>Exhaust turbocharger to panel holder for support to crankcase</b>			Used in step <a href="#">21</a>
Hexagon screw M8x16		Tightening torque	22 Nm
<b>Air conditioning compressor in component carrier</b>			Used in step <a href="#">21</a>
M10		Tightening torque	38 Nm

<b>Alternator to component carrier</b>			Used in step <a href="#">21</a>
M10x75		Tightening torque	38 Nm
M10x125		Tightening torque	38 Nm
M10x90		Tightening torque	38 Nm
<b>Deflecting element to belt tensioner</b>			Used in step <a href="#">21</a>
M8		Tightening torque	28 Nm
<b>Positive battery cable to the alternator</b>			Used in step <a href="#">21</a>
M8		Tightening torque	19 Nm
<b>Exhaust turbocharger to diesel particulate filter</b>			Used in step <a href="#">22</a>
Clamp	If necessary, renew clamp.	Tightening torque	13 Nm
<b>Exhaust-gas recirculation pipe for low-pressure exhaust-gas recirculation to exhaust manifold</b>			Used in step <a href="#">22</a>
M8		Tightening torque	19 Nm
<b>Metal holder for diesel particulate filter to crankcase</b>			Used in step <a href="#">22</a>
M8x16		Tightening torque	19 Nm
<b>Diesel particulate filter to crankcase holder</b>			Used in step <a href="#">22</a>
M8		Tightening torque	19 Nm
<b>Differential pressure sensor of diesel particulate filter on cylinder head cover</b>			Used in step <a href="#">22</a>
TS5x20		Tightening torque	4 Nm
<b>Differential pressure sensor for low-pressure exhaust-gas recirculation</b>			Used in step <a href="#">22</a>
TS5x20		Tightening torque	4 Nm
<b>Lower clean air pipe to exhaust turbocharger</b>			Used in step <a href="#">23</a>
M6x20	Renew screw.	Tightening torque	8 Nm
<b>Cable clip to clean air pipe</b>			Used in step <a href="#">23</a>
TS5x20		Tightening torque	4 Nm
<b>Output shaft to wheel bearing</b>			Used in step <a href="#">26</a>
M16	Replace collar bolt and spring.	Jointing torque	210 Nm
		Angle of rotation	90 °

## Overview of Special Tools

2 220 718 Workshop crane



GRWE0611-001

**Common**

Used in step [2](#) [12](#) [26](#)

Usage WSK 1000  
 Included in the tool or work  
 Storage location Individual  
 Replaced by  
 In connection with  
 SI-Number 06 01 11 (701)

**0 496 268 (11 0 390) Pin**

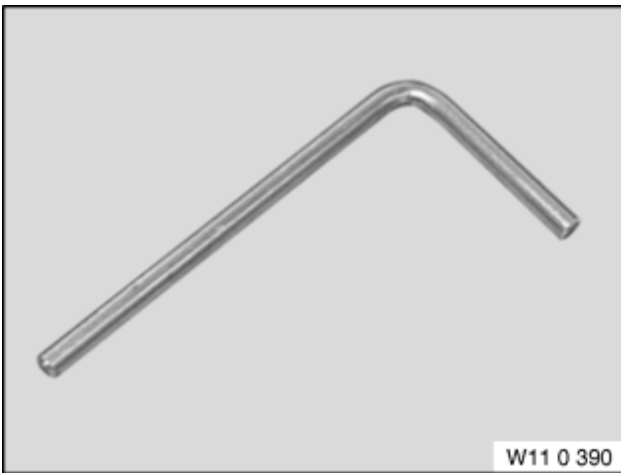

W11 0 390

**Common**

Used in step [7](#) [21](#)

Usage (roll pin) For securing new tensioning pulley (poly-V belt)  
 Included in the tool or work  
 Storage location B24  
 Replaced by  
 In connection with  
 SI-Number 01 15 07 (390)

**0 494 213 (24 2 390) Cap**



W24 2 390

**Common**

Used in step [9](#) [19](#)

Usage (protective cap) For sealing off the guide sleeve of the transmission connector  
 Included in the tool or work  
 Storage location C49  
 Replaced by  
 In connection with  
 SI-Number 01 14 01 (766)

**0 493 380 (11 6 480) Connector**

**Common**

Used in step [9](#) [19](#)

Usage For turning over engine at crankshaft

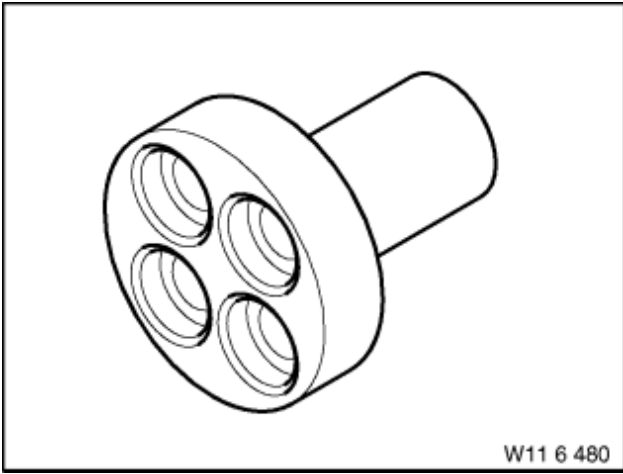

hub (vibration absorber).

Included in the tool or work

Storage location

Replaced by

In connection with

SI-Number 01 11 98 (338)

### 0 494 478 (24 4 161) Basic body

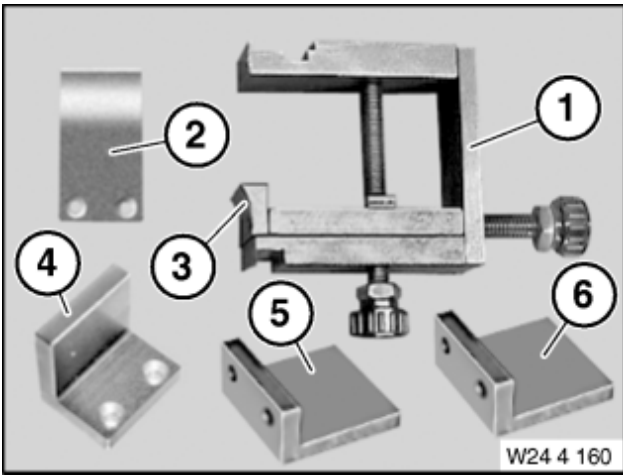

**Common**

Used in step [9](#)

Usage

Included in the tool or work

0 494 451

Storage location

B45

Replaced by

In connection with

SI-Number

### 0 494 622 (24 4 164) Shaped element

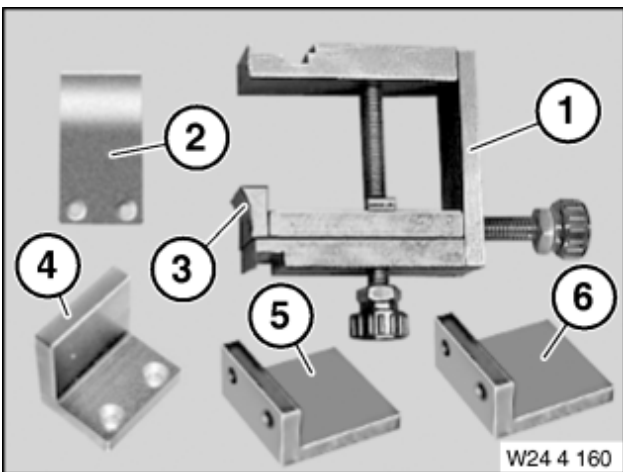

**Common**

Used in step [9](#)

Usage

For converter version M54 discontinued, available as part of set of special tools only

Included in the tool or work

0 494 451

Storage location

B45

Replaced by

In connection with

SI-Number

### 0 494 451 (24 4 160) Holder

**Common**

Used in step [9](#) [19](#)

Usage

For securing converter during removal and installation of transmission

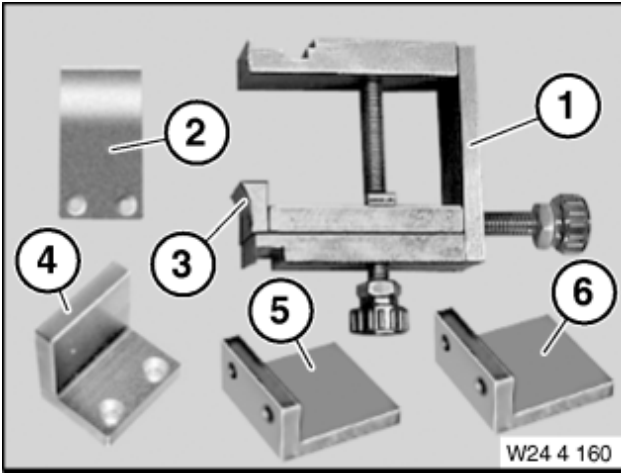

Included in the tool or work

Storage location B45

Replaced by

In connection with

SI-Number 01 11 02 (908)

**Consisting of**

Pos	BMW Order number	Replaced by	Designation	In Connection with
2	<a href="#">0 494 479 (24 4 162)</a>		<b>Shaped element</b> For converter version N73 discontinued, available as part of set of special tools only	
5	<a href="#">0 494 965 (24 4 165)</a>		<b>Shaped element</b> Transmission: GA6 HP19 in E87, E90 Discontinued, available as part of set of special tools only	
3	<a href="#">0 494 477 (24 4 163)</a>		<b>Shaped element</b> For converter version M57TU discontinued, available as part of set of special tools only	
1	<a href="#">0 494 478 (24 4 161)</a>		<b>Basic body</b>	

4 [0 494 622 \(24 4 164\)](#)

**Shaped element**  
For converter version M54 discontinued, available as part of set of special tools only

6 [0 496 061 \(24 4 166\)](#)

**Shaped element**  
Transmission: GA6L45R (GM6) in E83 / N52K  
Discontinued, available as part of set of special tools only

**0 495 187 (00 2 300) Assembly stand**

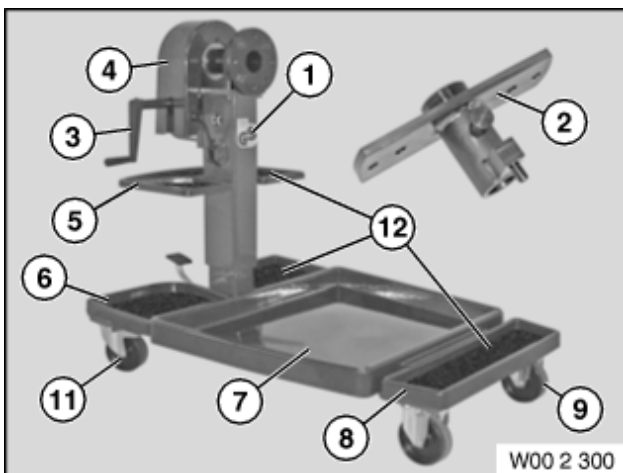

**Common** Used in step [14](#)

Usage Assembly stand with universal flange for mounting engines from S85

Included in the tool or work

Storage location Individual

Replaced by

In connection with

SI-Number 01 25 04 (155)

**Consisting of**

Pos	BMW Order number	Replaced by	Designation	In Connection with
1	<a href="#">0 495 188 (00 2 301)</a>		<b>Assembly stand</b> available only as complete assembly stand 83 30 0 495 187.	

			<p><b>Tool</b>  (Universal flange). Do not use any more!!!  Technically locked. Is replaced by a new flange with part number 83 30 2 299 563. All flanges delivered by the end of 2011 will be replaced free of charge. From 2012, only the new flange will be supplied. Also applies to the complete engine mounting stand 00 2 300.</p>
2	<u>0 495</u> <u>189 (00</u> <b>2 299 563</b> <u>2 302)</u>		
3	<u>0 495</u> <u>200 (00</u> <u>2 303)</u>		<b>Crank</b>
4	<u>0 495</u> <u>201 (00</u> <u>2 304)</u>		<b>Cover</b> (Protective hood)
5	<u>0 495</u> <u>202 (00</u> <u>2 305)</u>		<b>oddments tray</b> (Oddments tray for small parts)
6	<u>0 495</u> <u>203 (00</u> <u>2 306)</u>		<b>Shaped element</b> (Rear shaped pan)
7	<u>0 495</u> <u>204 (00</u> <u>2 307)</u>		<b>Collection pan</b> (Oil collection pan)
8	<u>0 495</u> <u>205 (00</u> <u>2 308)</u>		<b>Shaped element</b> (Front shaped pan)

9	<a href="#">0 495 206 (00 2 309)</a>	<b>Wheel</b> (Front wheel (without stop))
10	<a href="#">0 495 207 (00 2 311)</a>	<b>Wheel</b> (Rear wheel (with stop))
11	<a href="#">0 495 208 (00 2 312)</a>	<b>Mat</b> (Checker mat set)
2	<a href="#">2 299 563</a>	<b>Adapter</b> New adapter for the engine assembly stand. Replacement for 83 30 0 495 189 - 00 2 302.

## 2 413 082 Fixture



<b>Common</b>	Used in step <a href="#">14</a> <a href="#">15</a>
Usage	For mounting the engines on the assembly stand.
Included in the tool or work	
Storage location	Individual
Replaced by	
In connection with	0495196
SI-Number	01 23 15 (280)

## 2 411 719 Engine support



<b>Common</b>	Used in step <a href="#">14</a>
Usage	For engine support on the assembly stand. Engine N57; B57
Included in the tool or work	
Storage location	
Replaced by	
In connection with	2413082

SI-Number 01 24 15 (281)

### 0 490 189 (00 2 550) Measurement aid

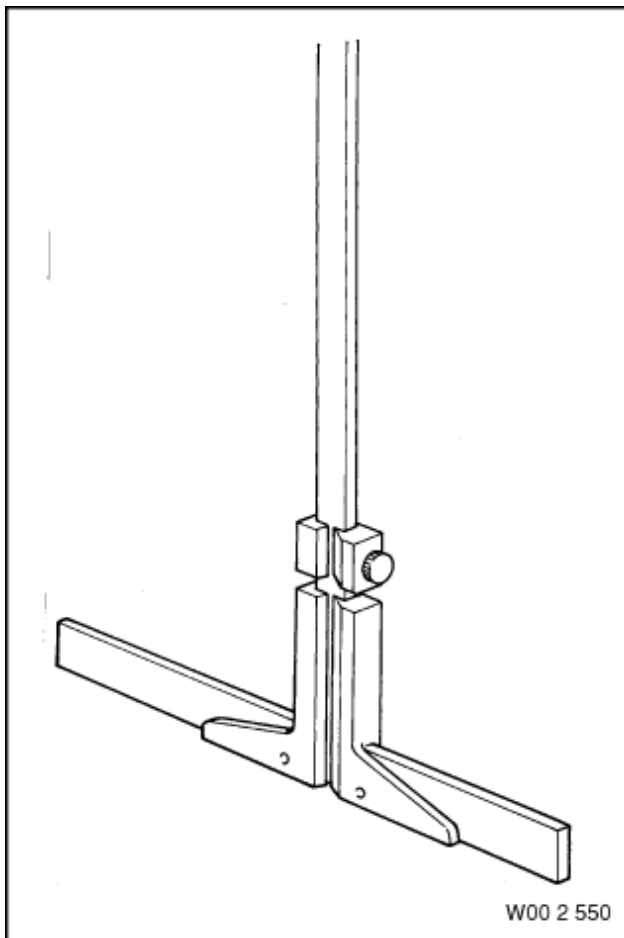

#### Common

Used in step [19](#)

Usage (Depth gauge) E.g. for determining side clearance of transmission shaft and basic adjustment dimension for installing bevel pinion in rear axle final drives

Included in the tool or work

Storage location A4

Replaced by

In connection with

SI-Number

### 0 491 667 (24 1 110) Socket wrench insert

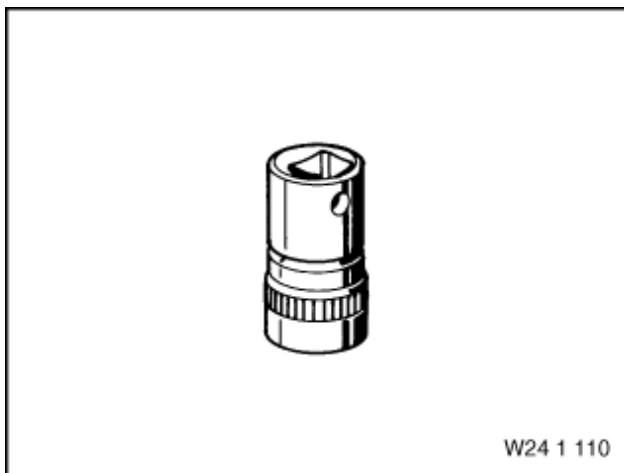

#### Common

Used in step [19](#)

Usage Loosening and fastening the converter fastener

Included in the tool or work

Storage location A14

Replaced by

In connection with

SI-Number 01 04 86 (566)

### 0 490 504 (00 9 120) Torque angle measuring dial

#### Common

Used in step [26](#)

Usage For torsion angle adjustment of cylinder head bolts (all engines) And reinforcement plate front axle support E46

Included in



the tool or work

Storage location **A4**

Replaced by

In connection with

SI-Number

**Replacement tools:  
2 299 563 Adapter**



**Common** Used in step **14**

---

Usage **New adapter for the engine assembly stand. Replacement for 83 30 0 495 189 - 00 2 302.**

Included in the tool or work **0 495 187**

Storage location

Replaced by

In connection with

SI-Number

## 24 00 117 Remove and install automatic transmission



**Materials harmful to health.**

**Contact with fluids harmful to health!**

- Note and follow safety information on containers.
- Conduct all work in appropriate personal protective equipment only.



**Damage to the engine block.**

**Serious damage to the engine block and transmission due to damaged and corroded bolts.**

- It is imperative that protruding threads of the transmission bolts are checked for corrosion and damage prior to removal.
- It is imperative that all rust is removed from corroded threads and that they are cleaned prior to removal.
- Renew rusted and damaged bolts.



**Damage of components in the engine compartment.**

**When removing the transmission, tilting of the engine may damage components in the engine compartment.**

- Before removing the transmission: Support engine.
- Secure the engine against tilt movements.
- Follow the specifications of the repair instructions.



**Damage to the transmission.**

**Damage to the transmission by unapproved transmission oil.**

- Use only the approved transmission oil.
- Check the transmission oil level after completing the repair.



**Only G05 and G07**

In vehicles with active anti-roll bar (ARS) the fan cowl must be removed in order to spin the engine.

For additional information see: 17 11 035 Removing and installing/replacing the fan cowl including electric fan

### PRELIMINARY WORK

---

#### 1 – Disconnecting all battery earth leads



- See additional information.

## 2 – Remove the underbody panelling of the transmission on the side

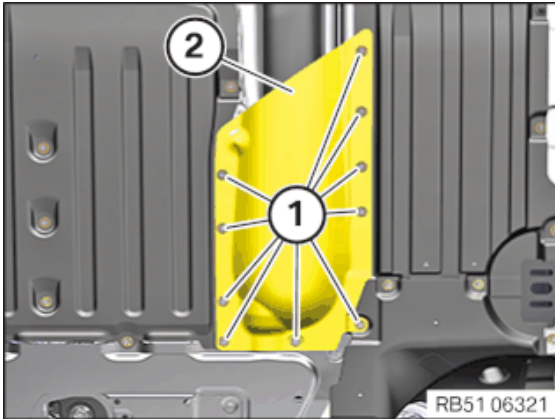

- Loosen screws (1).
- Remove the underbody panelling (2).

## 3 – Removing the front underbody protection



Different variants may be installed depending on the vehicle equipment.

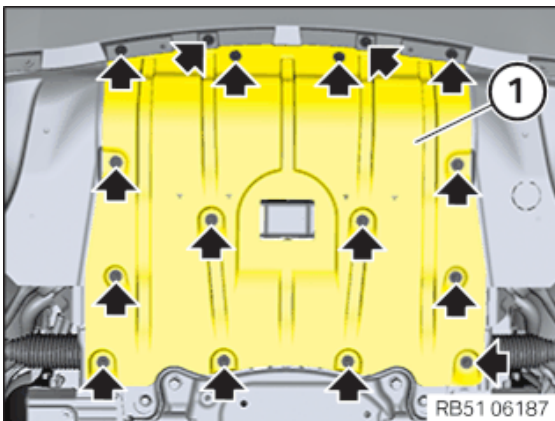

- Remove screws (arrows).
- Guide out front underbody protection (1) and remove it.

### ► Removing the front underride protection



The following work step(s) is / are to be carried out if the specified component(s) is/are fitted.

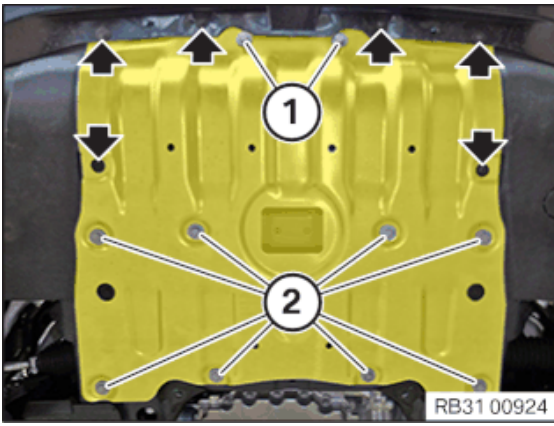

**i**

Secure component against falling.

- Remove screws (arrows).
- Loosen screws (1) and (2).
- Feed out and remove the front underride protection.

#### 4 – Removing the stiffening plate

**i**

Secure component against falling.

**i**

Driving without stiffening plate is not permissible.

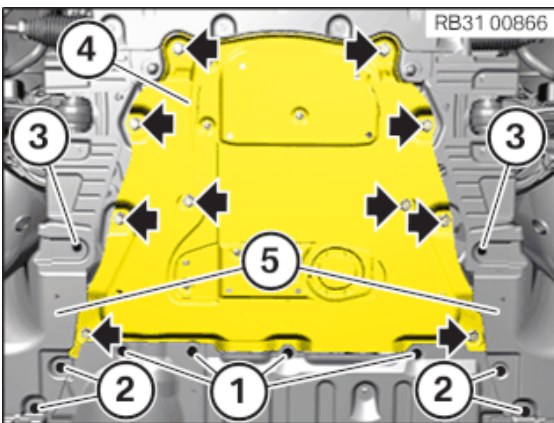

- Loosen screws (1) to (3).
- Remove screws (arrows).
- Feed out the stiffening plate (4) in the area (5) of the wheel arch trim panel and remove.

#### 5 – Remove rear underbody protection

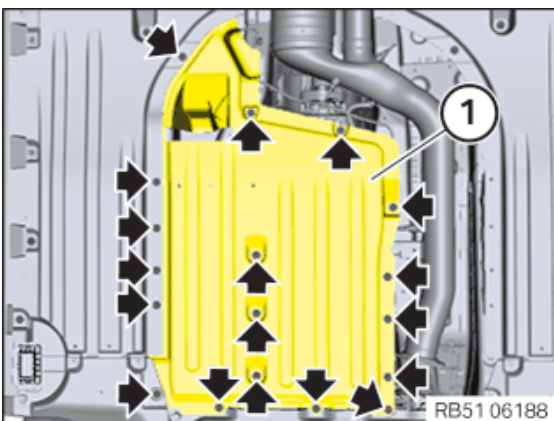

- Remove screws (arrows).
- Guide out underbody protection (1) and remove it.

#### 6 – Removing underbody panelling (tank cover)

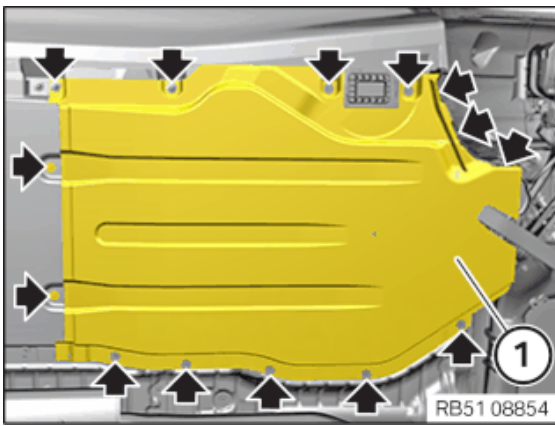

- Unscrew all bolts and nuts (arrows).
- Remove the underbody panelling (1).

## 7 – Removing the acoustic cover of the oil sump

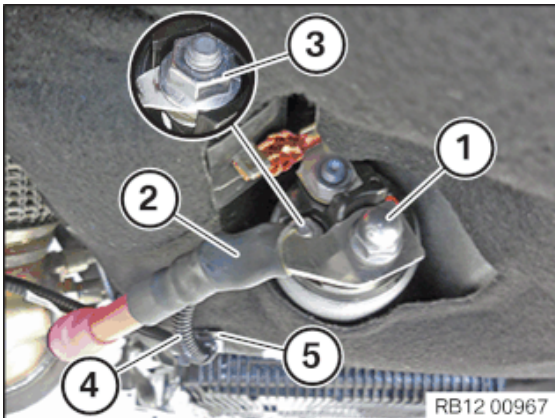

- Loosen nuts (1).
- Thread out positive battery cable (2) and set it aside.
- Loosen nut (3).
- Loosen clip (5).
- Feed out terminal 50 (4) and lay to one side.

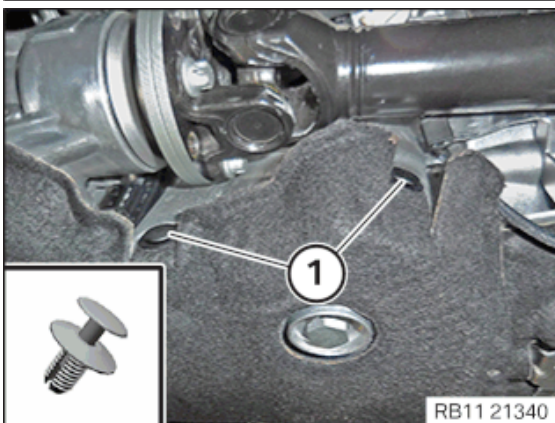

- Loosen the clips (1).

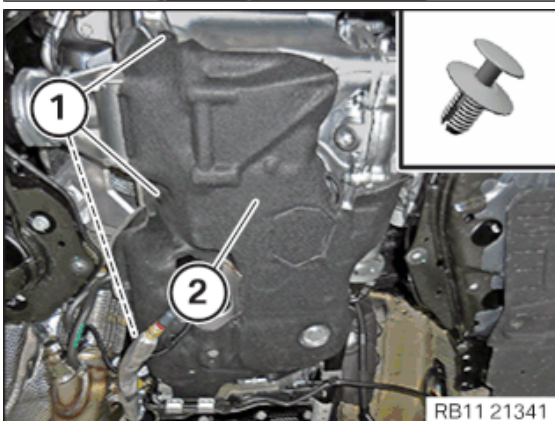

- Loosen the clips (1).
- Remove the acoustic cover (2) of the oil sump.

## 8 – Removing starter motor

### Prerequisite

Battery earth leads are disconnected.



**Hot surfaces.**

**Risk of burning!**

- Perform all work only on components that have cooled down.



**Working on 12 V vehicle electrical system.**

**Risk of short circuits! Risk of fire!**

- Make sure that **no charger** is connected to the jump start support point in the engine compartment.
- Detach battery earth lead from battery.
- With auxiliary batteries: Detach all battery earth leads from additional batteries.

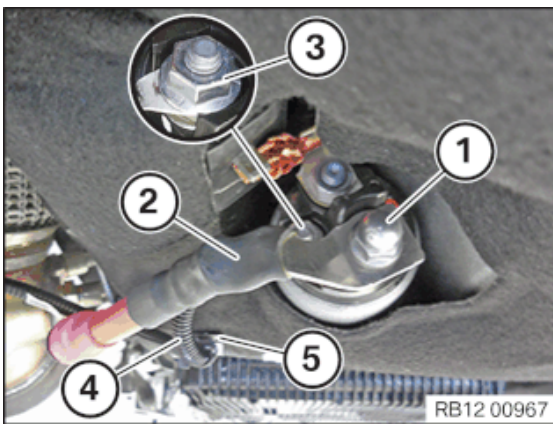

- Loosen nuts (1).
- Thread out positive battery cable (2) and set it aside.
- Loosen nut (3).
- Loosen clip (5).
- Feed out terminal 50 (4) and lay to one side.

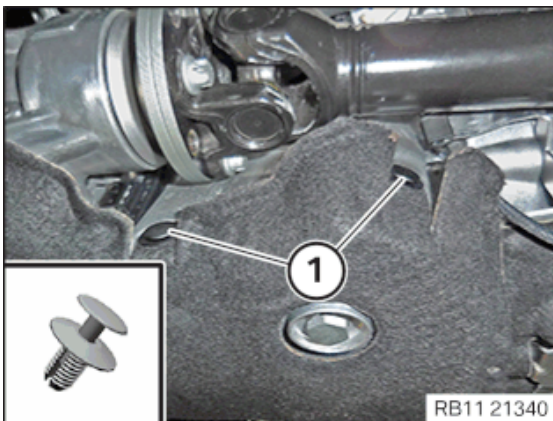

- Loosen the clips (1).

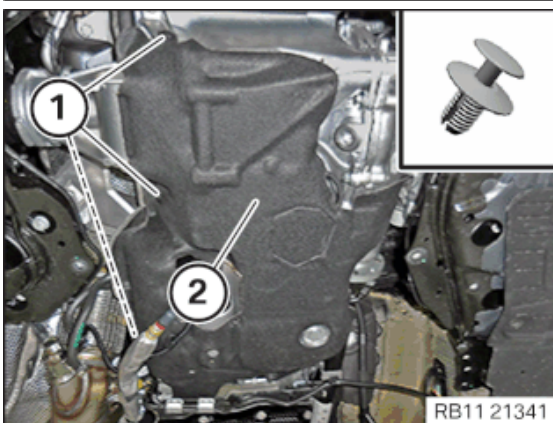

- Loosen the clips (1).
- Remove the acoustic cover (2) of the oil sump.

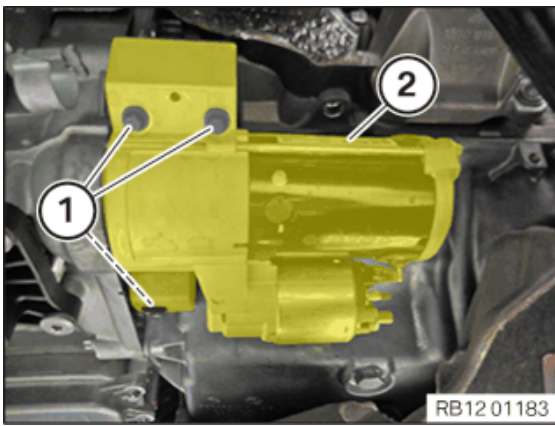

- Loosen screws (1).
- Remove the starter motor (2).

## 9 – Removing rear right tension strut



Description is for left component only. Procedure on the right side is identical.

### ► Removing rear tension strut



Driving without the strut brace/front-end strut or tension strut is not permitted.

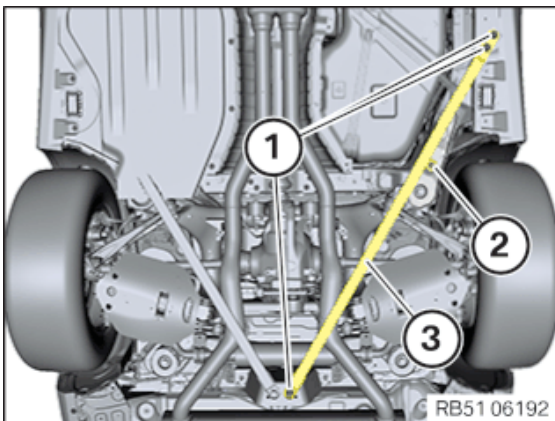

- Unscrew the bolts (1) and the nut (2).
- Remove tension strut (3).

## 10 – Removing the left and right rear diffuser



Description is for left component only. Procedure on the right side is identical.

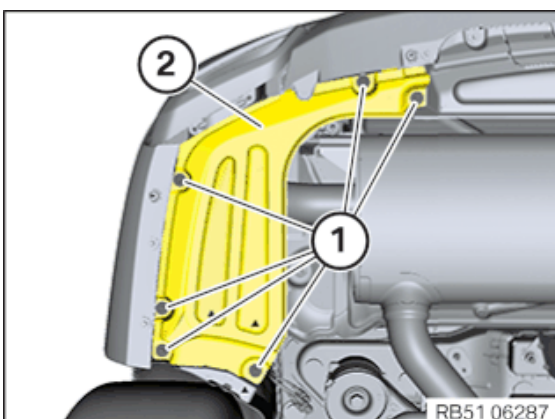

- Loosen screws (1).
- Guide the rear diffuser (2) out and remove.

## 11 – Remove exhaust system



**Hot exhaust system.**

**Risk of burning!**

- Any work must exclusively be carried out with an exhaust system that has cooled down.



**Hot surfaces.**

**Risk of burning!**

- Perform all work only on components that have cooled down.



**Component with heavy weight.**

**Danger of injury!**

- Note component's centre of gravity.
- Support component using a jack.
- Secure component against falling off the jack.

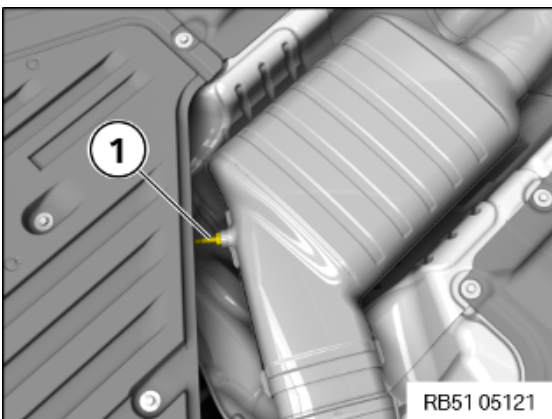

- Loosen exhaust temperature sensor (1).

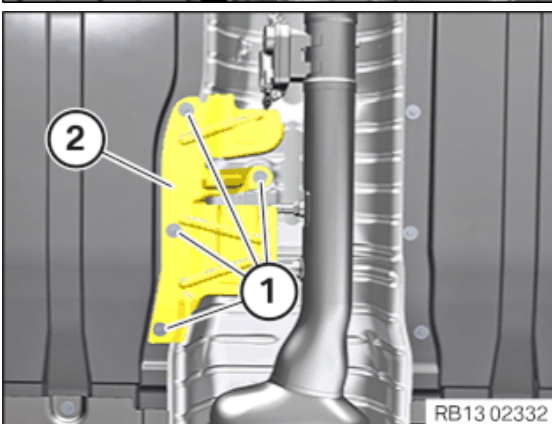

- Loosen screws (1).
- Remove the protective plate (2).

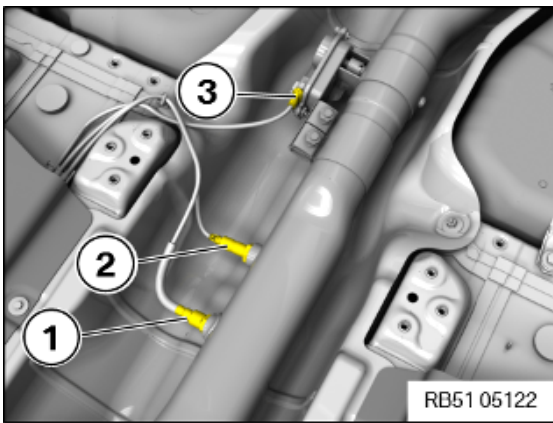

- Release the diesel particulate sensor (1) and the nitrogen oxide sensor (2).
- Unlock plug connection (3) and disconnect.

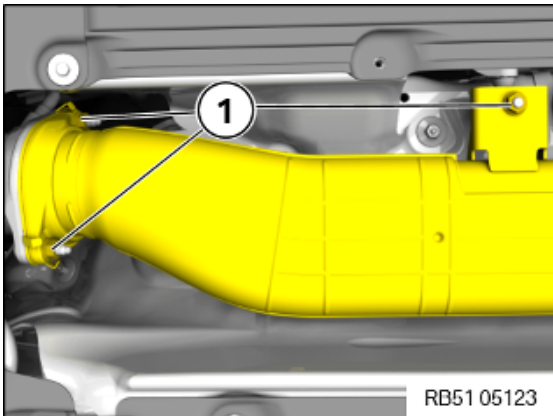

- Loosen nuts (1).

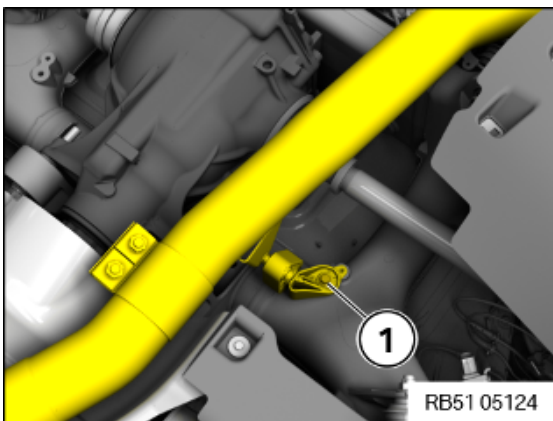

- Unscrew the bolt (1) from the rear axle support.

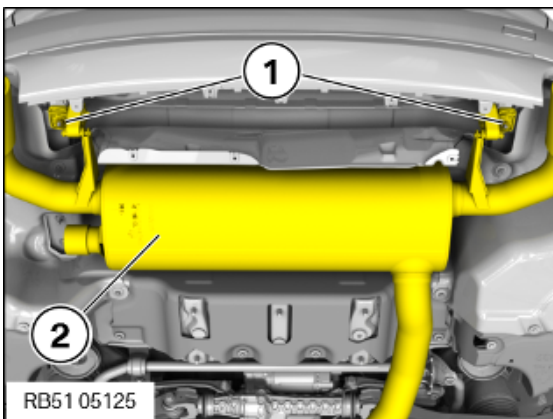

- Loosen nuts (1).
- Lower and remove the exhaust system (2) with the assistance of a second person.

## 12 – Remove the heat shield

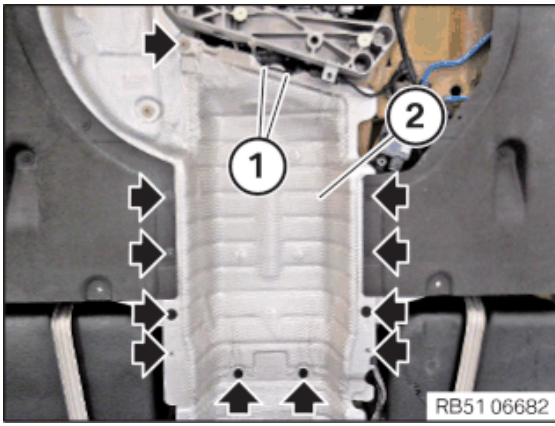

- Detach clamps (1) (B57).
- Loosen nuts and bolts (arrows).
- Remove the heat shield (2).

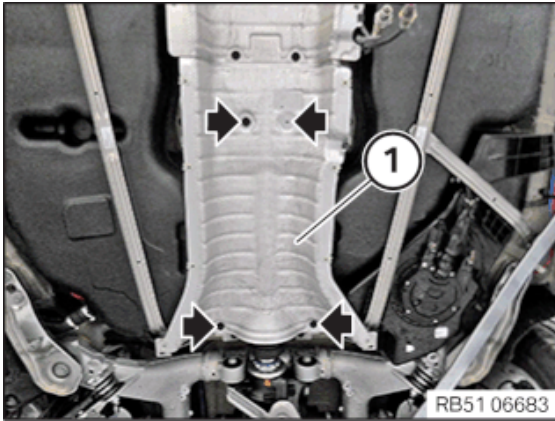

- Loosen screws (arrows).
- Remove the heat shield (1).

### 13 – Remove the connecting support from the tunnel

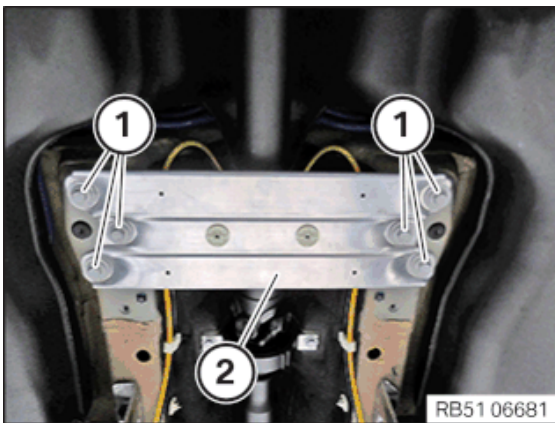

- Loosen screws (1).
- Remove the connecting support (2) at the tunnel.

### 14 – Remove the retaining plates

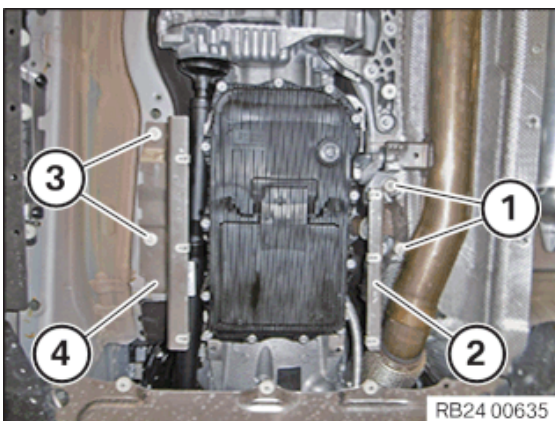

- Loosen nuts (1) and (3).
- Remove retaining plates (2) and (4).

### 15 – Partially releasing propeller shaft



### Damage to propeller shaft during removal.

**Non-observance of the removal guidelines for the propeller shaft on the rear axle differential may cause severe damage.**

- Do not disassemble the three-hole flange, flexible disc and propeller shaft. The three-hole flange to the rear axle differential is balanced with the flexible disc and propeller shaft.
- Loosen the recessed nut against the direction of travel in clockwise direction. The propeller shaft must be loosened on the recessed nut only and exclusively in the direction of rotation otherwise the anti-twist lock of the bi-hexagonal flange nut is damaged.
- In the event of a damaged anti-twist lock on the bi-hexagonal flange nut: Replace the rear axle differential.

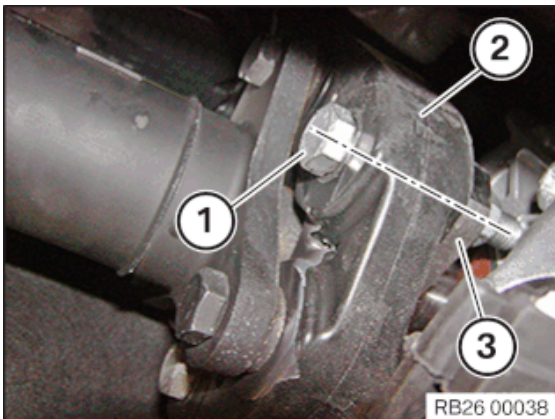

- Mark installation position of screw connection (1) of flexible disc (2) and of three-hole flange (3).

The mark makes it possible for the propeller shaft to be installed again in the same position. This should prevent a humming noise from the drive train during driving.

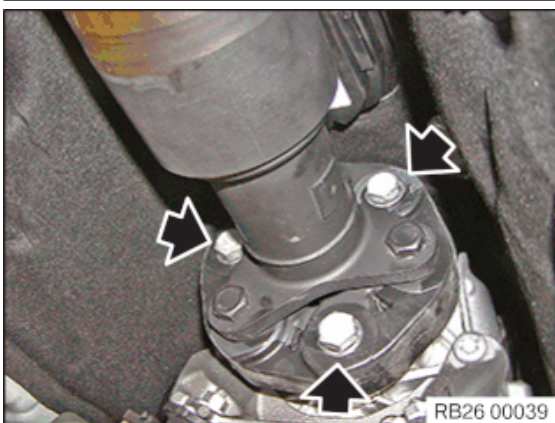

- Remove screws (arrows).

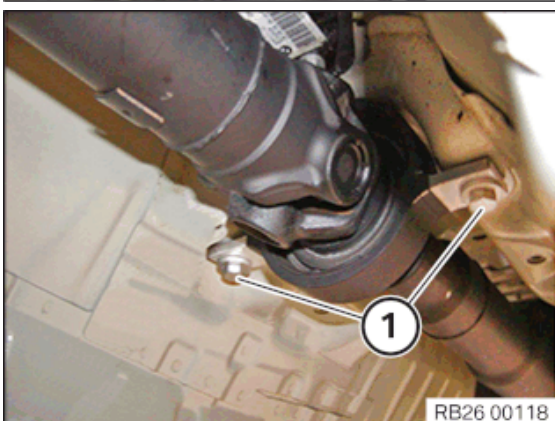

- Unscrew the bolts (1) on the centre mount and hold down the propeller shaft.  
Major deflection angles of the propeller shaft may damage the propeller shaft and/or the joints.
- Tie up propeller shaft to underbody.

## MAIN WORK

### 16 – Remove automatic transmission (all-wheel drive vehicle) (GA8HP76Z)



### Materials harmful to health.

#### Contact with fluids harmful to health!

- Note and follow safety information on containers.
- Conduct all work in appropriate personal protective equipment only.



### Damage to the engine block.

#### Serious damage to the engine block and transmission due to damaged and corroded bolts.

- It is imperative that protruding threads of the transmission bolts are checked for corrosion and damage prior to removal.
- It is imperative that all rust is removed from corroded threads and that they are cleaned prior to removal.
- Renew rusted and damaged bolts.



### Damage of components in the engine compartment.

#### When removing the transmission, tilting of the engine may damage components in the engine compartment.

- Before removing the transmission: Support engine.
- Secure the engine against tilt movements.
- Follow the specifications of the repair instructions.



### Damage to the transmission.

#### Damage to the transmission by unapproved transmission oil.

- Use only the approved transmission oil.
- Check the transmission oil level after completing the repair.

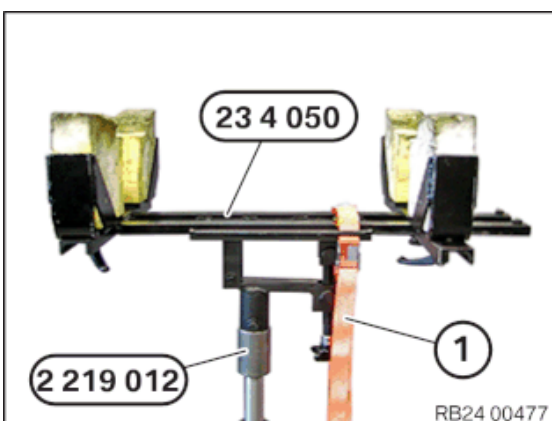

- Support the transmission using special tools **0 495 498 (23 4 050)** and **2 219 012**.
- Secure the transmission with a tensing strap (1).

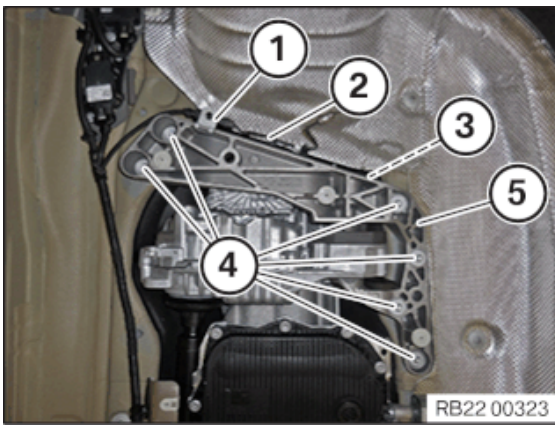

- Loosen clamp (1).
- Hang cable (2) to the side.
- Loosen screws (4).
- Loosen screw (3).
- Remove the transmission cross member (5).

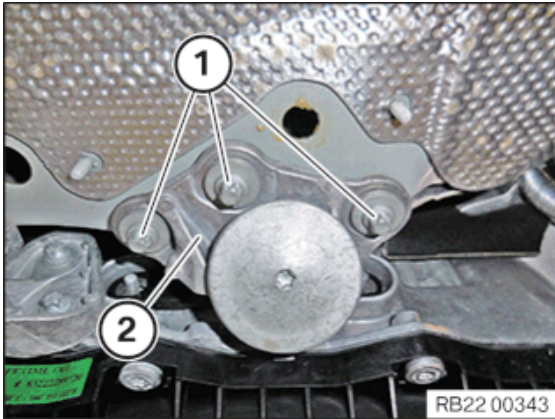

- **Version A:**  
Unscrew the bolts (1) on the transmission bearing support (2).

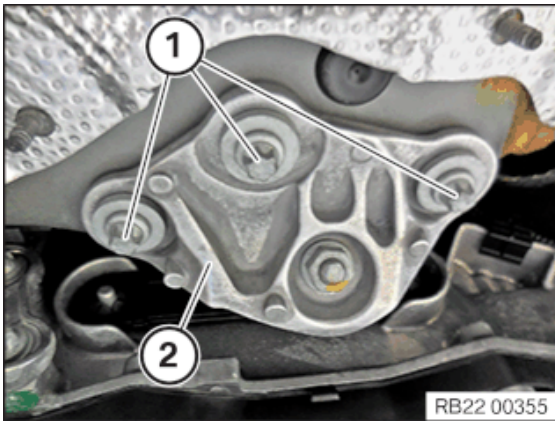

- **Version B:**  
Unscrew the bolts (1) on the transmission bearing support (2).

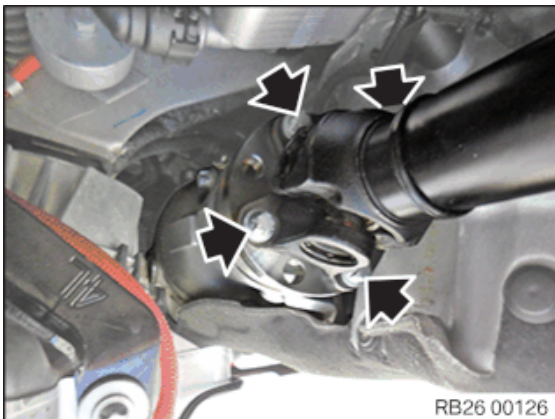

- Remove screws (arrows).
- Secure the propeller shaft on the transmission with a strap.

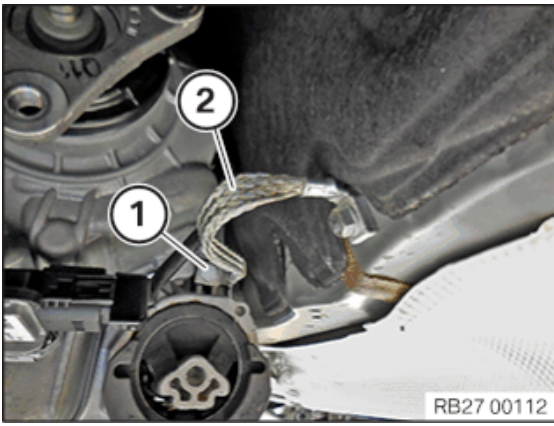

- Unscrew the bolt (1) and disconnect the ground strap (2).

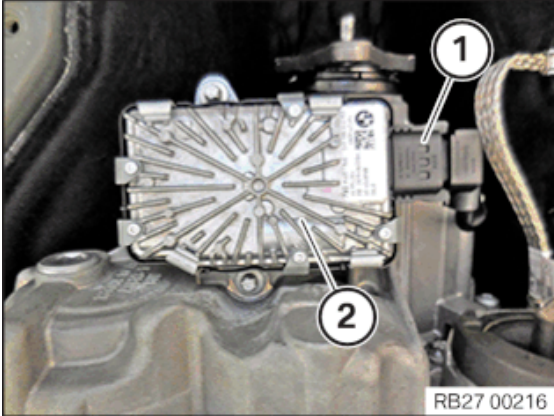

- Disconnect connector (1) from transfer box control unit (longitudinal torque distribution) (2).

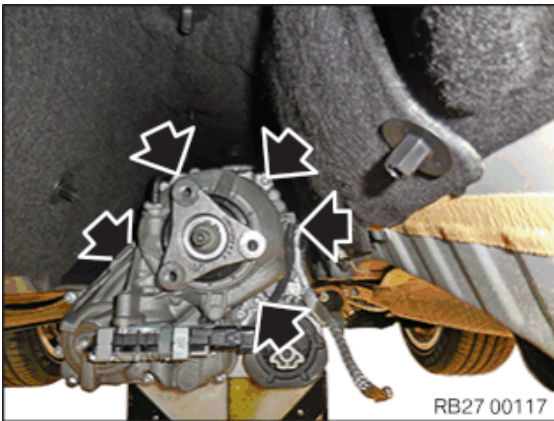

- Unscrew the screw connection (arrows) of the transfer box.
- Carefully remove the transfer box with the front propeller shaft. It is imperative to prevent damage to the surface coating!

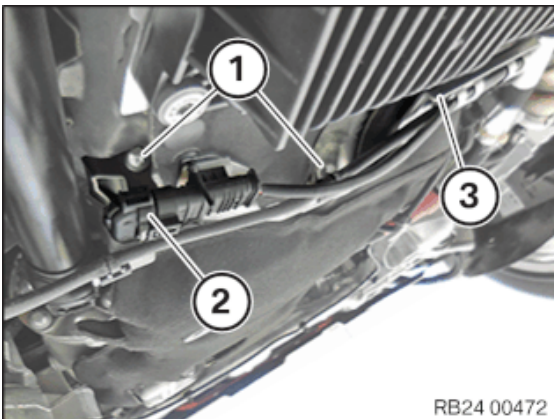

- Loosen screws (1).
- Disconnect the plug connection (2).
- Remove holder (3).

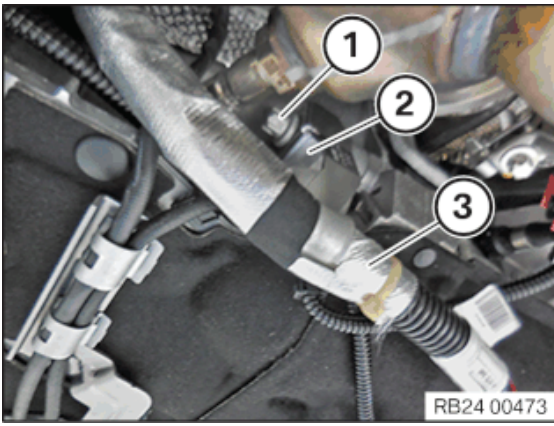

- Detach the line (3) from the holder (2).
- Loosen screw (1).
- Remove holder (2).

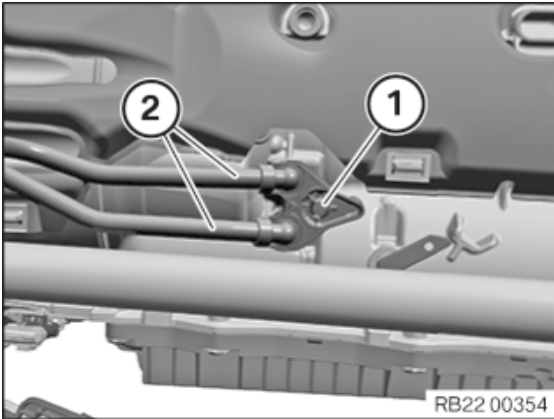

- Loosen screw (1).
- Disconnect hydraulic lines (2) to transmission oil cooler.

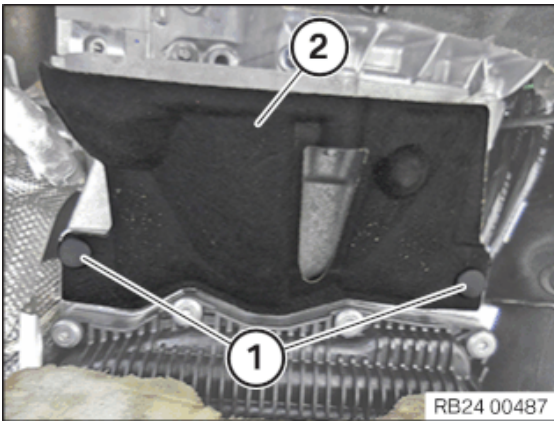

- Pull the expanding rivet (1) off.
- Remove the acoustic cover (2).

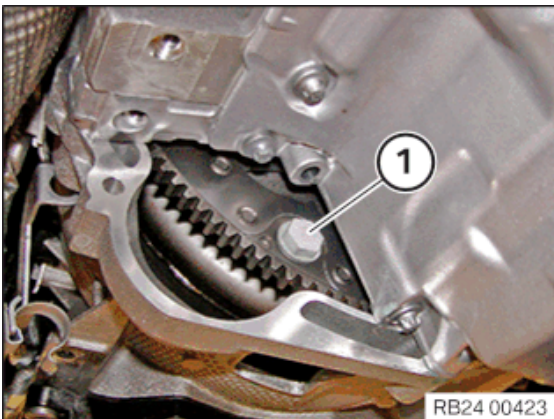

- i**
- Only G05 and G07**  
 In vehicles with active anti-roll bar (ARS) the fan cowl must be removed in order to spin the engine.  
 For additional information see: 17 11 035 Removing and installing/replacing the fan cowl including electric fan
- Turn the engine on the vibration damper with the special tool **0 493 380 (11 6 480)** in the direction of rotation until the bolt (1) becomes visible in the recess.
  - Undo all 6 screws (1) on the torque converter.

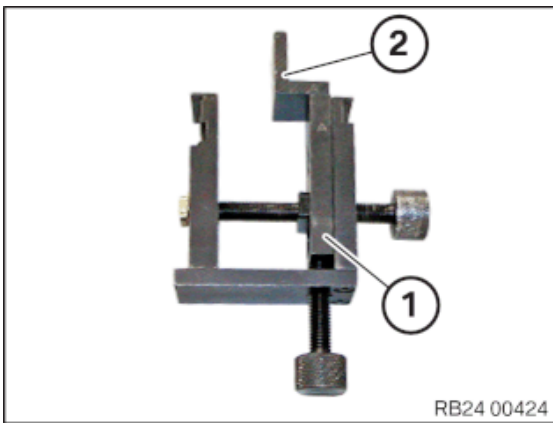

- Prepare special tool **0 494 478 (24 4 161)** (1) with the shaped element **0 494 622 (24 4 164)** (2) as shown.

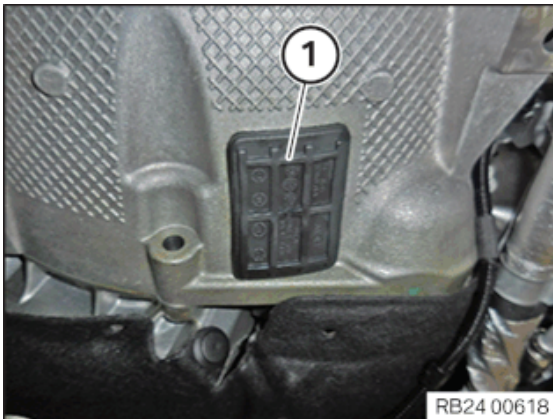

- Remove the sealing cap (1).

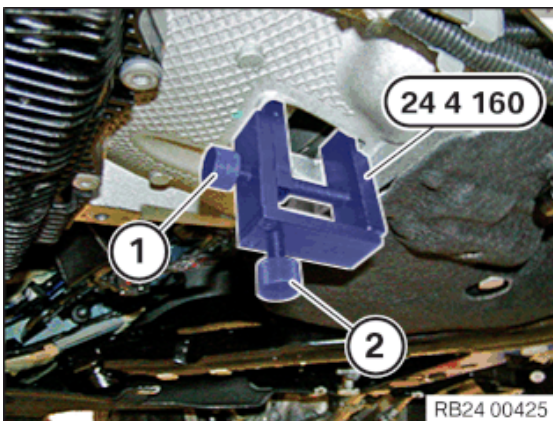

- Insert special tool **0 494 451 (24 4 160)** into the recess of the transmission housing and apply slight tension using the screw (1).
- Screw the bolt (2) in to the stop.
- Tighten down screw (1).

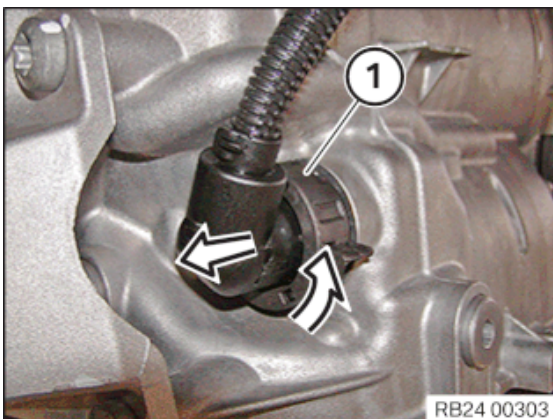

**i**

Notes on mechatronics are a fundamental requirement for these repair instructions and must be complied with at all times.

For additional information see: 24 34 ... Notes on mechatronics (GA8HP50Z/GA8HP51Z/GA8HP75Z/GA8HP76Z/GA8HP95Z)

- Unlock and pull off the connector (1) by turning it in the direction of the arrow.
- Do not touch pins.
- Loosen all cable clips.

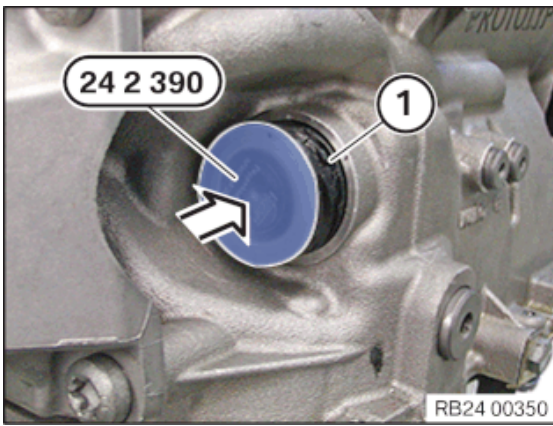

- Insert the special tool **0 494 213 (24 2 390)** in the sealing sleeve (1) in direction of arrow.

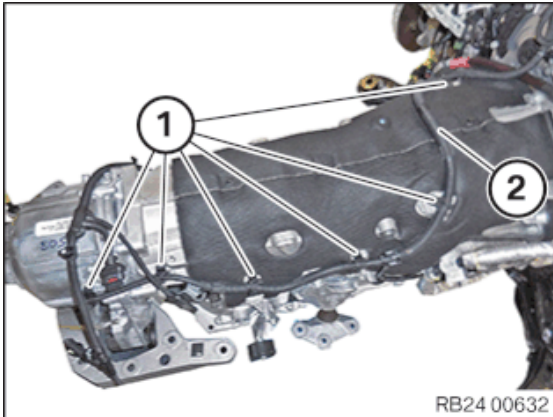

- Loosen clamps (1).
- Hang line (2) on one side.

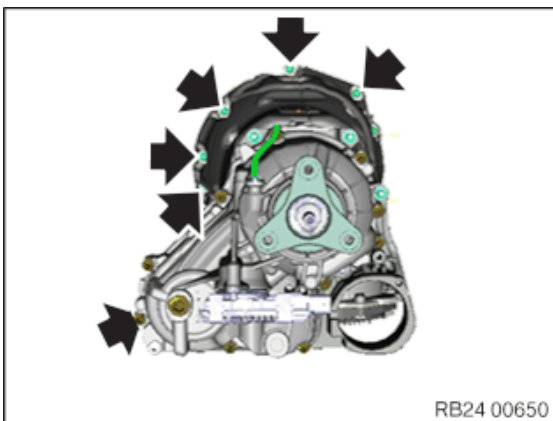

- Support engine.
- Remove screws (arrows).
- Remove transmission.

## 17 – Install automatic transmission (all-wheel drive vehicle) (GA8HP76Z)



### **Damage to the transmission.**

### **Damage to the transmission by unapproved transmission oil.**

- Use only the approved transmission oil.
- Check the transmission oil level after completing the repair.

### ► **Checking mounting orientation of torque converter**

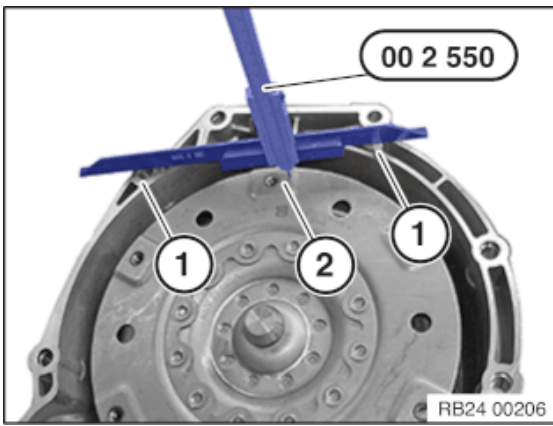

**Damage to the automatic transmission/impeller.**

**When disconnecting the engine and transmission, the torque converter can become loose! Failure to observe the correct installation positions of the torque converter may lead to damage to the impeller driver.**

- Make sure that the torque converter is in the correct installation position before installing the automatic transmission.

- Check the installation dimension between the contact surfaces (1) and the outer edge (2) of the torque converter threaded hole using special tool **0 490 189 (00 2 550)**.

See repair instructions

Remove and install/replace torque converter ()

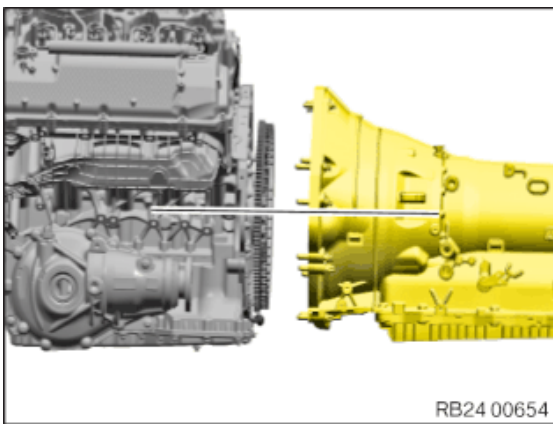

**Damage to flywheel and automatic transmission.**

**If the automatic transmission is not fitted horizontally while removing and installing it, then this can cause damage to the automatic transmission or the flywheel.**

- While removing and installing, align the automatic transmission fully horizontal to the engine.
- Check for a correct alignment before tightening the transmission bolts.

- Align the automatic transmission horizontal to the engine before installation.

- Check the fitting sleeves (1) for correct fit and damage and renew as needed.

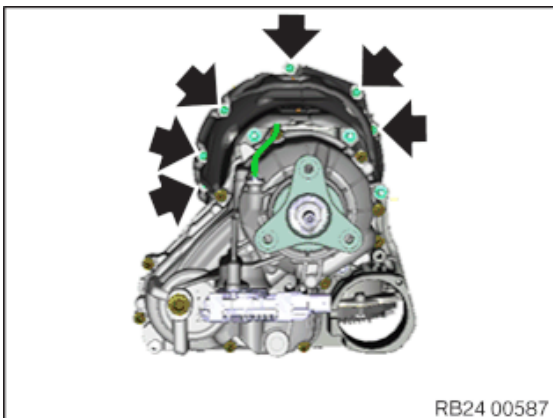
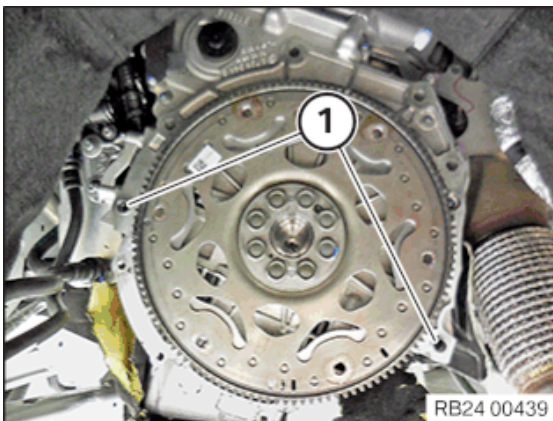

- Flange-mount the transmission.
- Turn torque converter until bore hole of torque converter is aligned with bore hole of flywheel.
- Fit the transmission bolts (arrows) and apply hand-tight.

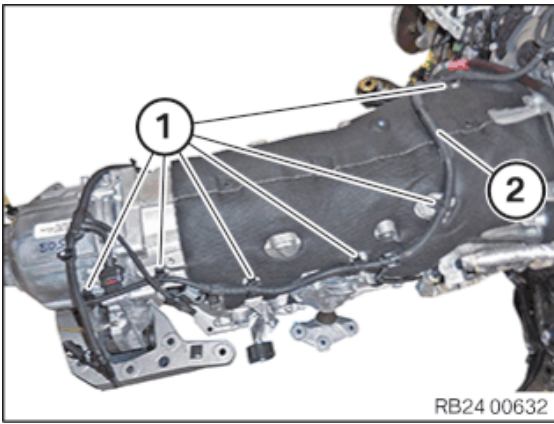

- Install the line (2).
- Secure clamps (1).

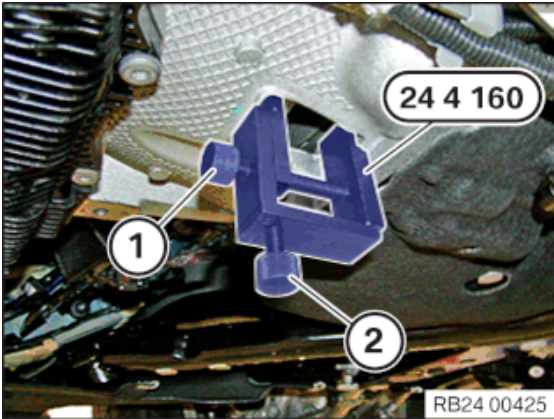

- Release screw (1) and screw (2).
- Remove special tool **0 494 451 (24 4 160)**.

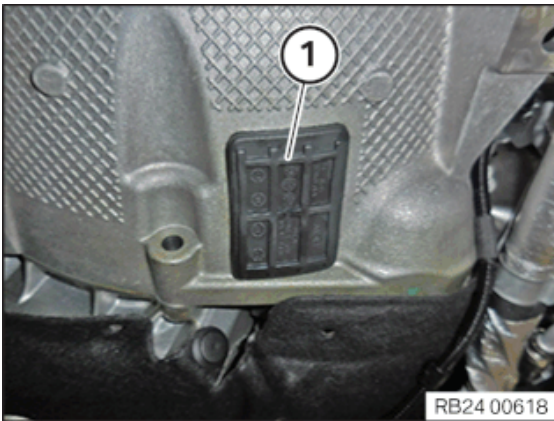

- Install the sealing cap (1).

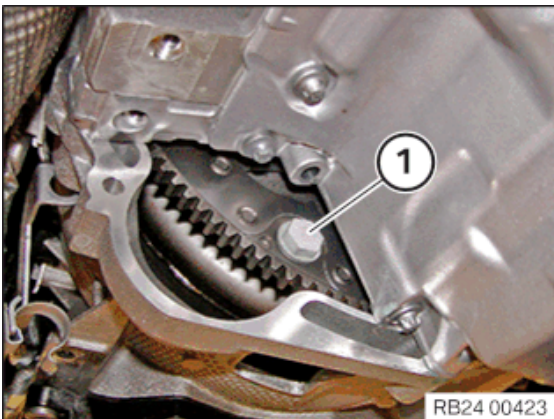

- Renew screws.  
**Parts:** Screws
- Crank the engine on the vibration damper in the direction of rotation using special tool **0 493 380 (11 6 480)** to tighten all six screws (1).
- Tighten all 6 screws (1) of the torque converter using special tool **0 491 667 (24 1 110)**.

#### **Torque converter to flywheel**

M10	Renew screws.	Tightening torque	56 Nm
-----	---------------	-------------------	-------

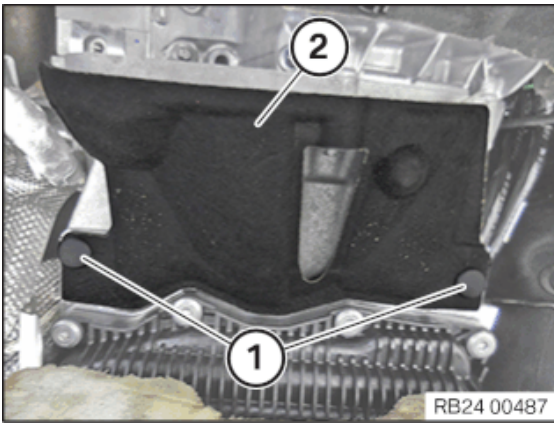

- Install acoustic cover (2).
- Install the expanding rivet (1).

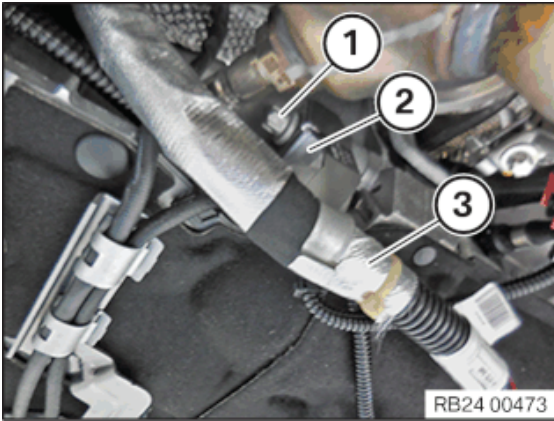

- Install holder (2).
- Position the screw (1) and hand-tighten.
- Clip in line (3) to holder (2).

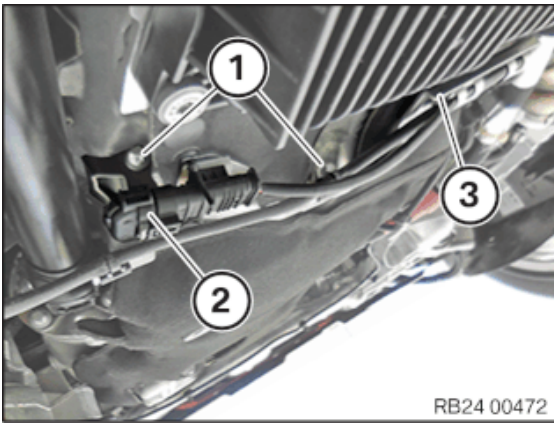

- Install holder (3).
- Connect connectors (2) and lock.
- Position the screws (1) and hand-tighten.

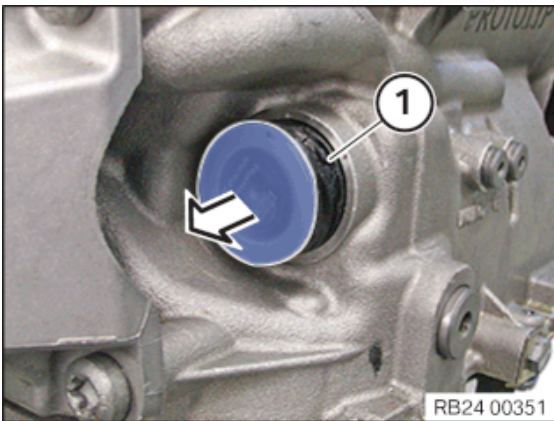

- Remove the special tool **0 494 213 (24 2 390)** from the sealing sleeve in direction of arrow.

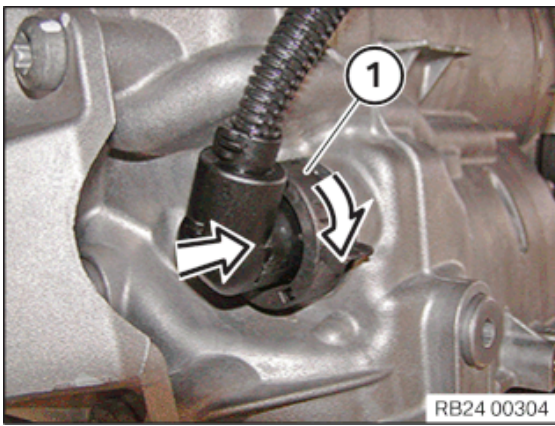

Notes on mechatronics are a fundamental requirement for these repair instructions and must be complied with at all times.

For additional information see: 24 34 ... Notes on mechatronics  
(GA8HP50Z/GA8HP51Z/GA8HP75Z/GA8HP76Z/GA8HP95Z)

- Slide the connector (1) on and turn it to lock.
- Tighten the transmission bolts in sequence (1) to (9).

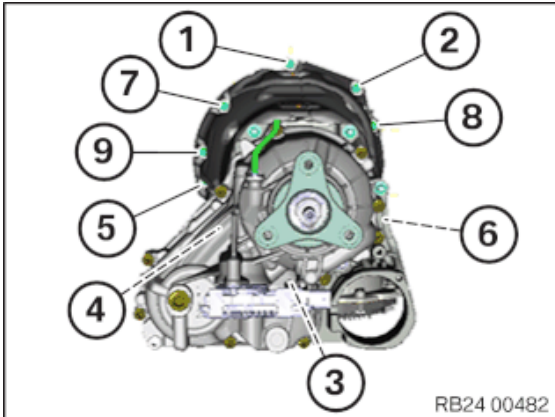

#### Transmission to engine

M8	Tightening torque	19 Nm
M12	Tightening torque	66 Nm

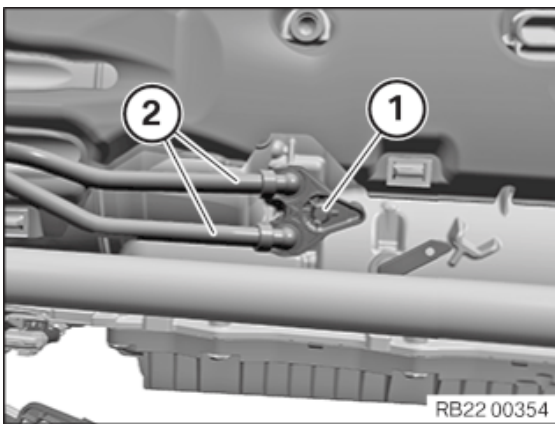

- Renew sealing rings.  
**Parts:** Sealing ring
- Install hydraulic lines (2) on transmission.
- Position and tighten the screw (1).

#### Transmission oil line to transmission

M6x25	Renew the sealing ring.	Tightening torque	8 Nm
-------	-------------------------	-------------------	------

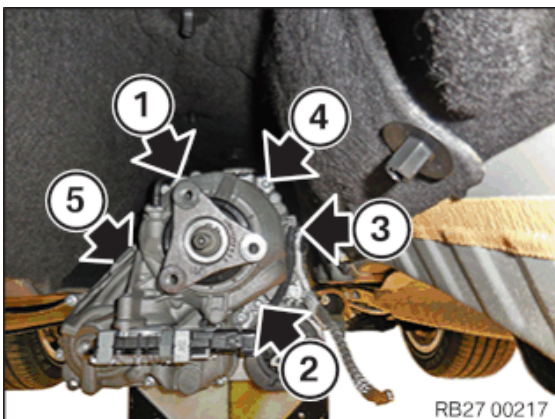

When assembling, it is essential to observe screwing sequences and tightening torques.

Non-observance of these requirements may result in leaks and damage.

- Tighten screws in the order (1) to (5).

#### Transfer box to automatic transmission

M10	Tightening torque	43 Nm
-----	-------------------	-------

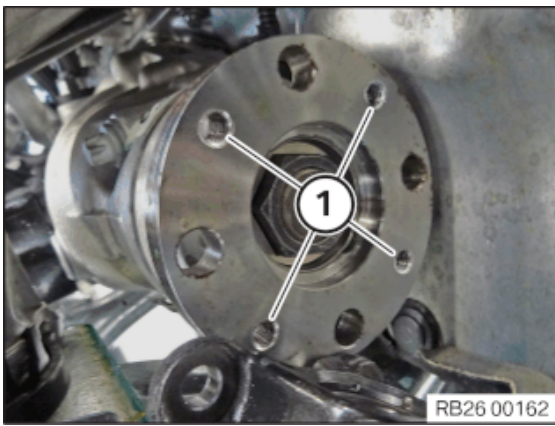

- Before fitting the propeller shaft to the front axle transmission, all the 4 threads (1) must be cleaned and free from possible residues and contaminations in the front axle transmission flange.

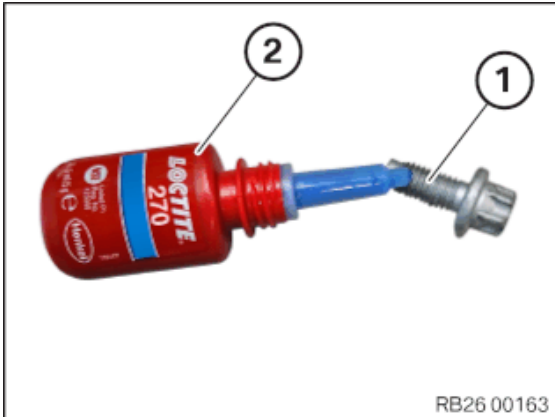

- Renew screws.

**Parts:** Screws

- A drop of Loctite 270 (2) must be given before the screw connection on each thread at the end of the respective screw (1).

**Expendable materials**

High-strength screw lock, Loctite 270	10 ml, Tube	83 19 2 210 337
--	----------------	-----------------

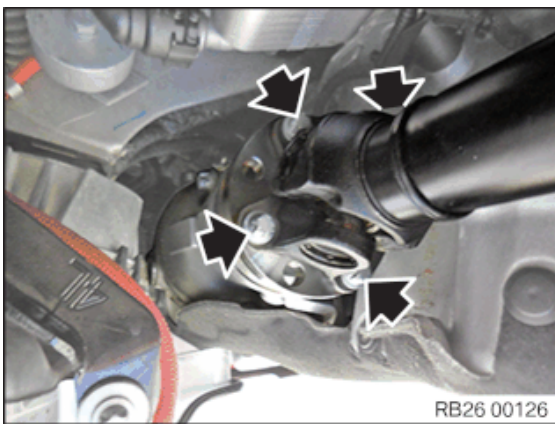

**i** A 30-minute hardening time must be ensured after screwing the front propeller shaft before the vehicle is driven again.

- Tighten screws (arrows).

**Propeller shaft before the front axle differential**

Renew screws.	Tightening torque	20 Nm
Jointing torque and angle of rotation must be observed without fail.	Angle of rotation	45 °

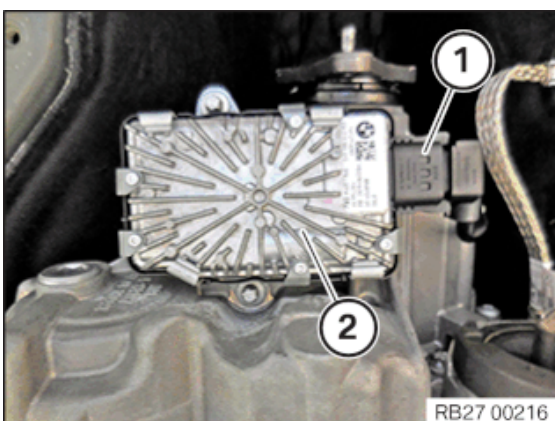

- Connect the connector (1) on the VTG control unit (longitudinal torque distribution) (2).

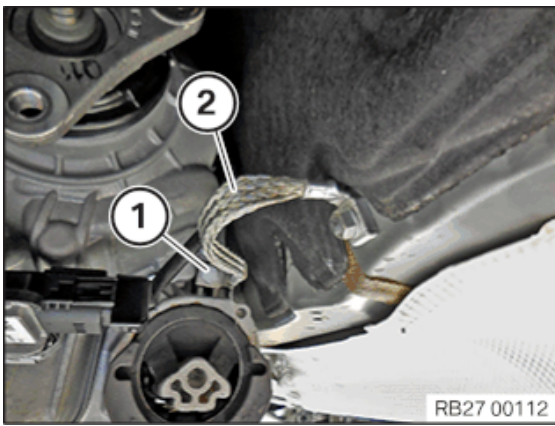

- Install the ground strap (2).
- Tighten down screw (1).

#### Ground strap to transmission or body

M8	Tightening torque	19 Nm
----	-------------------	-------

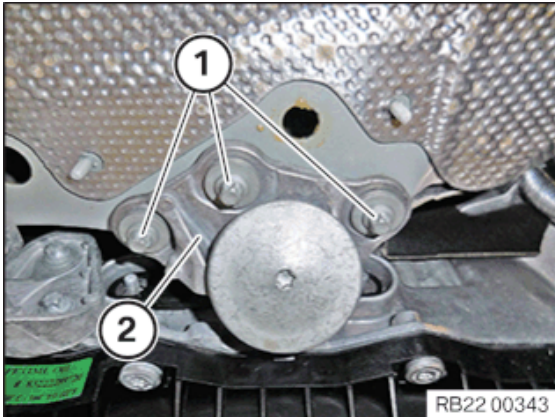

- **Version 1:**
- Position transmission bearing support (2).
- Tighten the screws (1).

#### Transmission bearing support to body

M8	Tightening torque	19 Nm
----	-------------------	-------

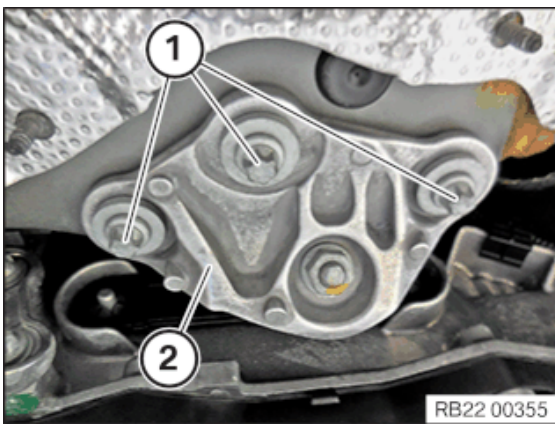

- **Version 2:**
- Position transmission bearing support (2).
- Tighten the screws (1).

#### Transmission bearing support to body

M8	Tightening torque	19 Nm
----	-------------------	-------

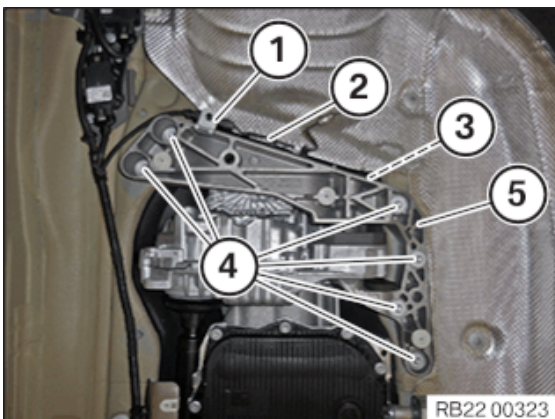

- Fit the transmission cross-member (5).
- Tighten the screws (4).

#### Transmission cross member to body

M8	Tightening torque	19 Nm
----	-------------------	-------

- Tighten down screw (3).

#### Transmission cross member to rubber mounts

M12	Tightening torque	68 Nm
-----	-------------------	-------

- Install (2) cable.
- Secure cable with (1) clamp.

## POSTPROCESSES

### 18 – Securing propeller shaft (partially removed)

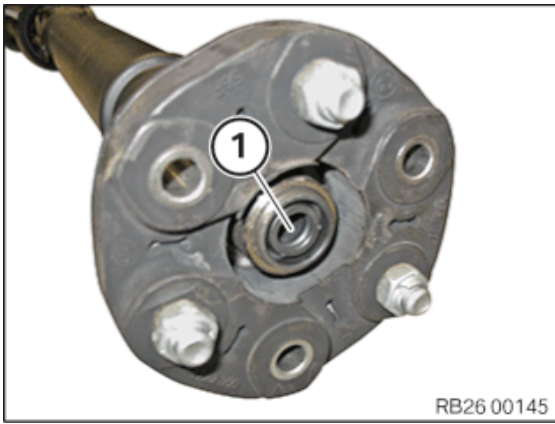

- Check centring (1) for damage; renew if necessary.

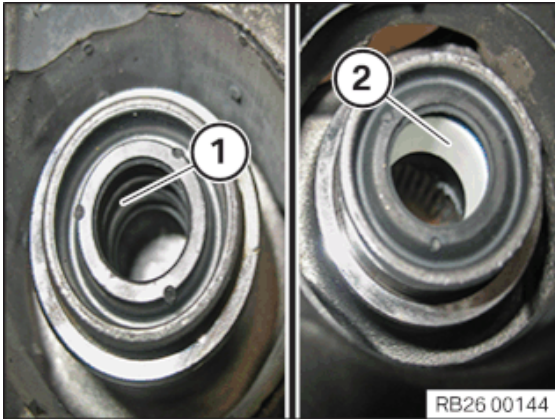

- Apply a thin coat of grease to the soft centring (1), if necessary.  
Do not grease the hard centring (2).

**Expendable materials**

---

Lubricating grease Olistamoly 2	100 g,	83 19 0 447 919
LN 584 LO	Tube	

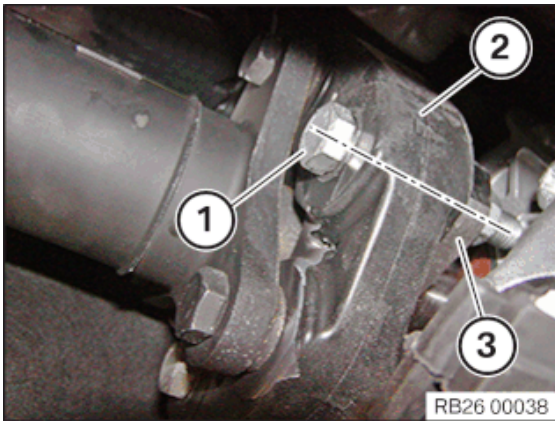

- Renew screws and the self-locking nuts.  
**Parts:** Screws, self-locking nuts
- Assemble the screw connections (1) of the flexible disc (2) and the three-hole flange (3) according to the self-affixed identification.  
This should prevent a humming noise from the drive train during driving.

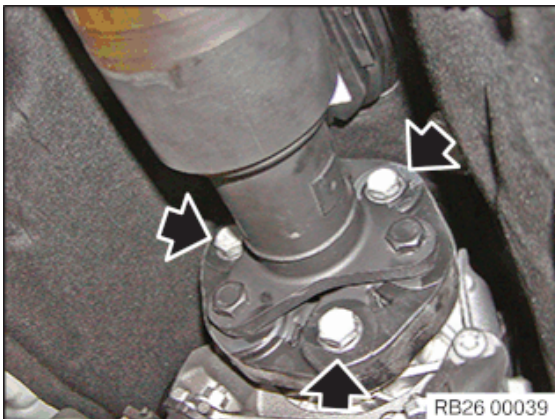

- Hand-tighten the screws and nuts (arrows), but do not tighten fully.

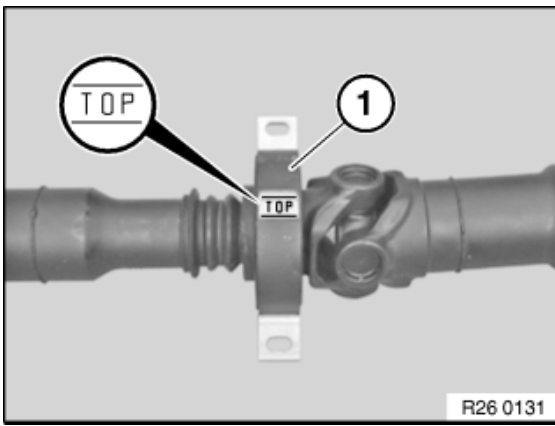

- Install the centre mount (1) with the designation **TOP** at the top in the transmission tunnel.

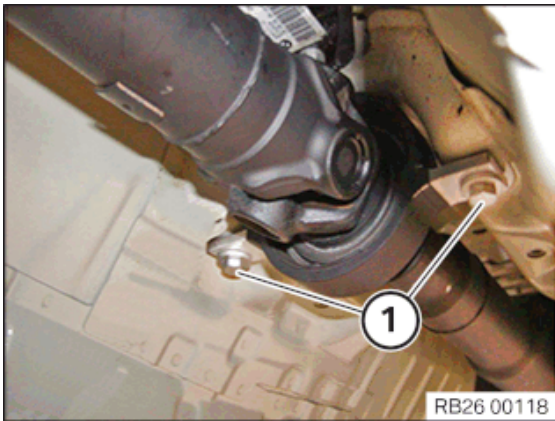

- Position centre mount.
- Hand-tighten the bolts (1), but do not tighten fully.

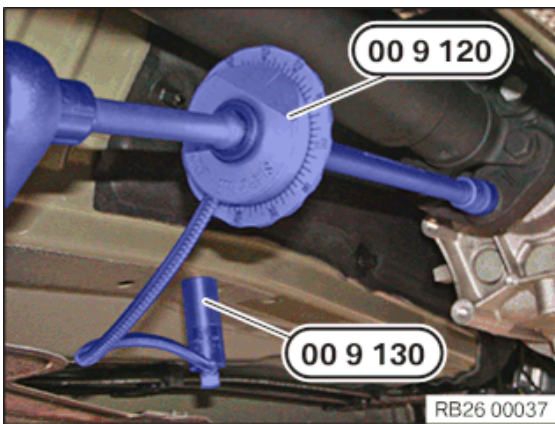

- Renew screws.

**Parts:** Screws

- Provide counter support for the bolts of the flexible disc on the nut and tighten with the bolts.

#### Front flexible disc to propeller shaft

M12	Renew screws. Comply with jointing torque and angle of rotation.	Jointing torque	55 Nm
	Tightening via screw.	Angle of rotation	90 °

- Secure the special tool **0 490 504 (00 9 120)** with the special tool on the vehicle underbody and continue to screw it in according to the angle of rotation.

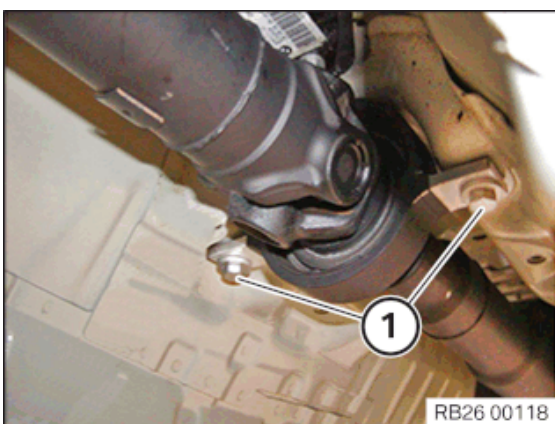

- Tighten the screws (1).

#### Centre mount to body

M8		Tightening torque	19 Nm
----	--	-------------------	-------

## 19 – Install the retaining plates

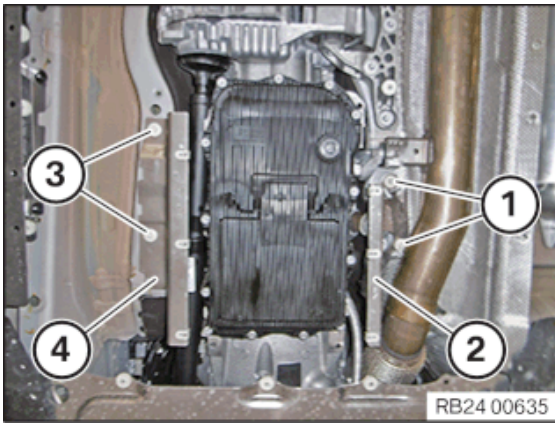

- Install the retaining plates (2) and (4).
- Install the nuts (1) and (3) and tighten.

#### Retaining plates for vehicle underbody cover

Sheet metal nut/plastic nut	Renew nuts.	Tightening torque	3 Nm
-----------------------------	-------------	-------------------	------

### 20 – Installing the connecting supports on the tunnel

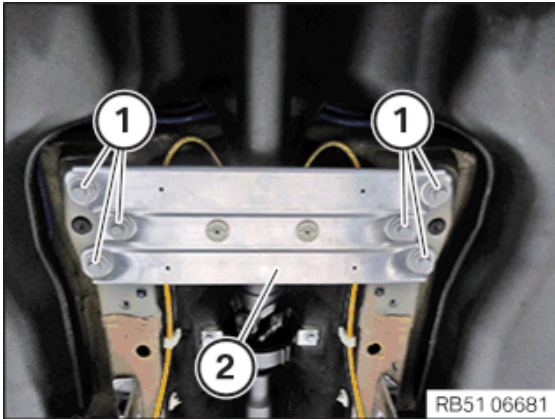

- Position the connecting support (2) on the tunnel.
- Renew screws (1).

**Parts:** Screws

- Tighten the screws (1).

#### Connecting support on tunnel to body

Hexagon screw M10x25	Replace screws	Tightening torque	56 Nm
		Angle of rotation	90 °

### 21 – Installing the heat shields

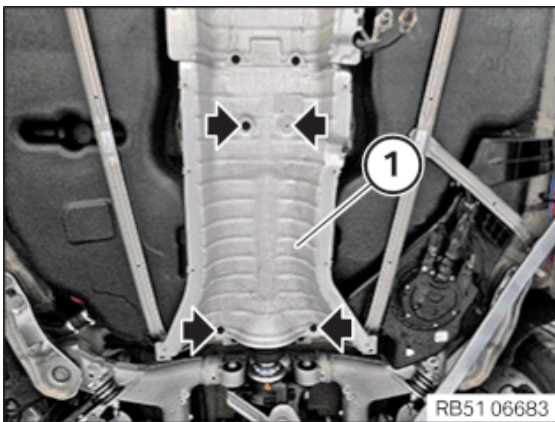

- Install heat shield (1).
- Tighten screws (arrows).

#### Heat shield to undercarriage

Screws and nuts		Tightening torque	3 Nm
-----------------	--	-------------------	------

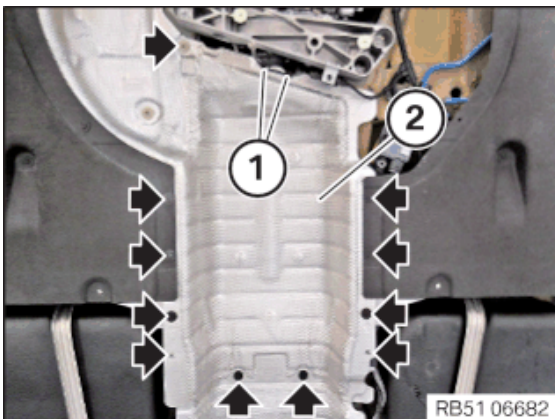

- Install heat shield (2).
- Tighten the nuts and bolts (arrows).

#### Heat shield to undercarriage

Screws and nuts		Tightening torque	3 Nm
-----------------	--	-------------------	------

- Secure (1)clamps (B57).

### 22 – Installing the exhaust system



### Component with heavy weight.

#### Danger of injury!

- Note component's centre of gravity.
- Support component using a jack.
- Secure component against falling off the jack.



### Heavy component.

#### Heavy components can lead to injury or damage.

- Remove and install heavy components with the aid of another person/other persons.



Check the exhaust system for tightness after installation.



Mount the exhaust system in voltage-free state, maintaining the tightening sequence from the rear silencer towards the exhaust manifold.

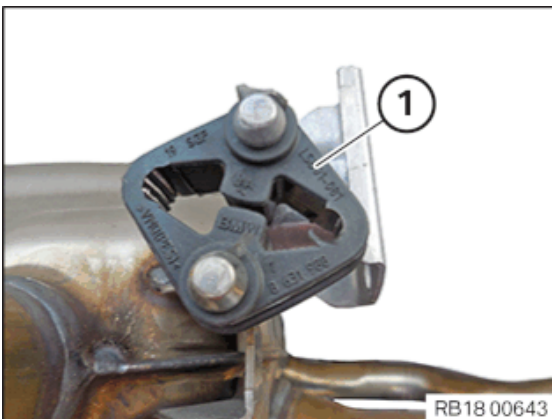

Schematic diagram is for example purposes. Some parts may differ in certain details.

- Check all rubber mounts (1) of the exhaust system for damage and renew where necessary.
- Renew the sealing ring (1) of the diesel particulate filter (2).

**Parts:** Sealing ring

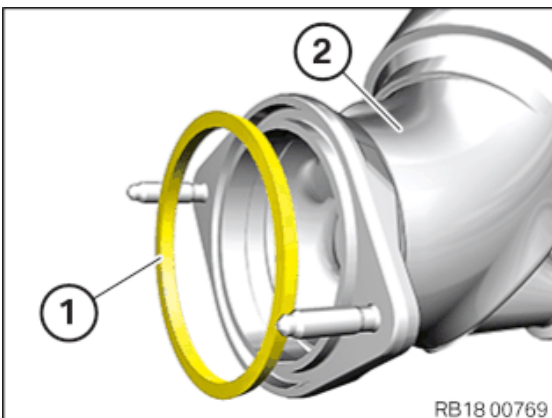

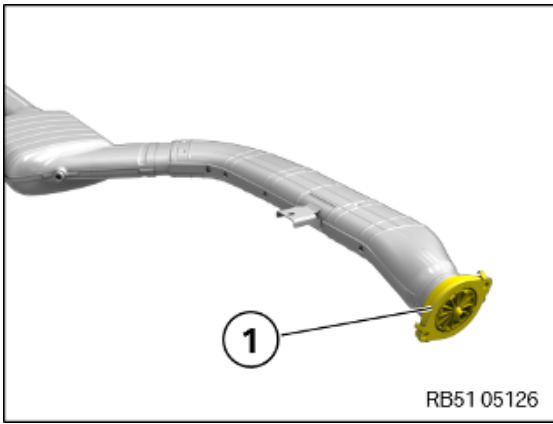

- Check the mixer (1) for damage, renew if necessary.

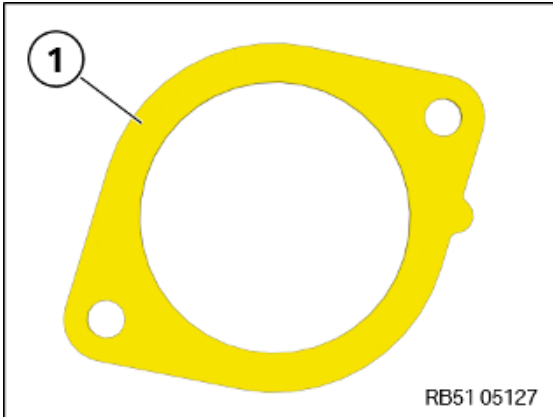

- Renew the seal (1).

**Parts:** Gasket

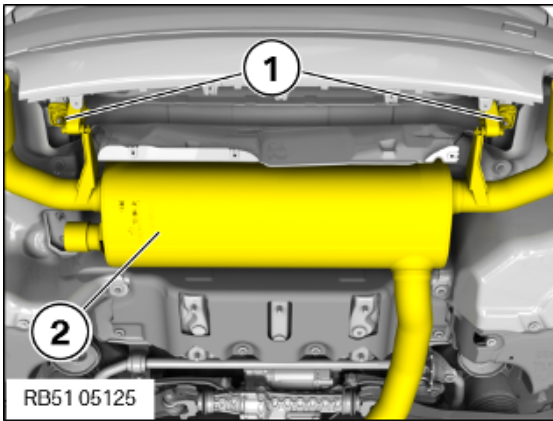

Conduct the following operation with the assistance of a second person.

- Insert and install the exhaust system (2) with the help of an auxiliary person.

- Renew nuts (1).

**Parts:** Nuts

- Tighten nuts (1).

#### Rear silencer to body / bumper support

M8	Replace nuts.	Tightening torque	19 Nm
----	---------------	-------------------	-------

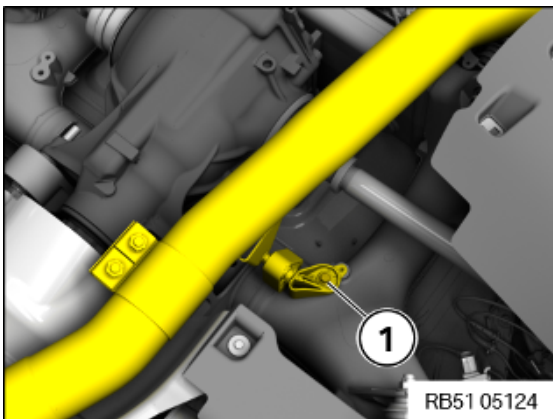

- Renew the screw (1).

**Parts:** Screw

- Tighten the bolt (1) on the rear axle support.

#### Exhaust system to rear axle carrier

M8x25	Renew screw.	Tightening torque	28 Nm
-------	--------------	-------------------	-------

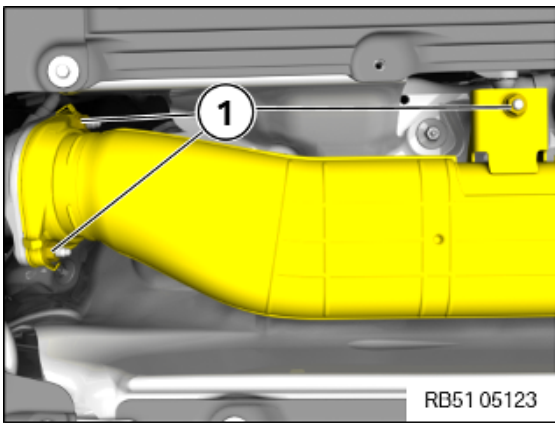

Mount the exhaust system in voltage-free state, maintaining the tightening sequence from the rear silencer towards the exhaust manifold.

- Renew nuts (1).

**Parts:** Nuts

- Tighten nuts (1).

#### Exhaust system to diesel particle filter

M8	Renew gasket.	Tightening torque	19 Nm
----	---------------	-------------------	-------

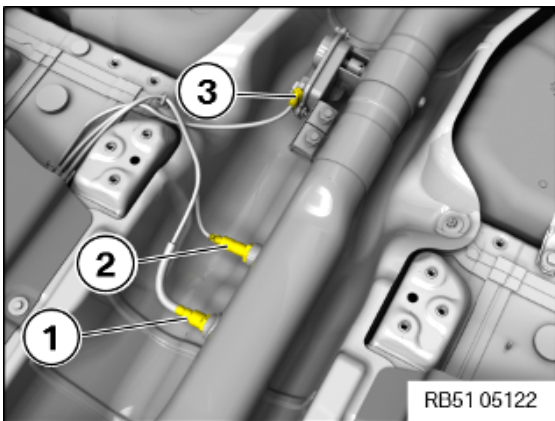

- Connect connectors (3) and lock.  
The connector (3) must engage audibly.
- Tighten the nitrogen oxide sensor (2).

#### Nitrogen oxide sensor downstream of SCR catalytic converter

Sensor		Tightening torque	55 Nm
--------	--	-------------------	-------

- Tighten the diesel particulate sensor (1).

#### Diesel particulate sensor to exhaust system

Sensor		Tightening torque	50 Nm
--------	--	-------------------	-------

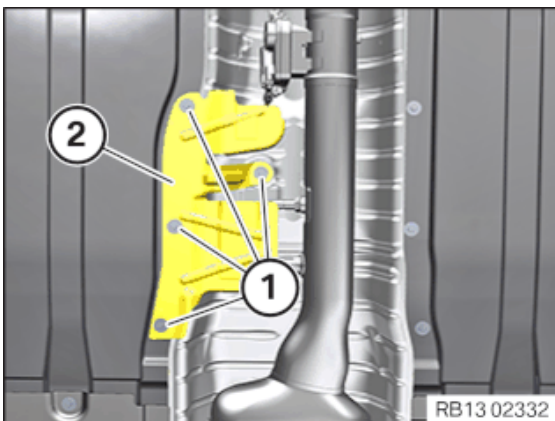

- Insert and install protective plate (2).
- Tighten the screws (1).

#### Protective plate for SCR exhaust gas sensor system

Hexagon screw		Tightening torque	2,6 Nm
---------------	--	-------------------	--------

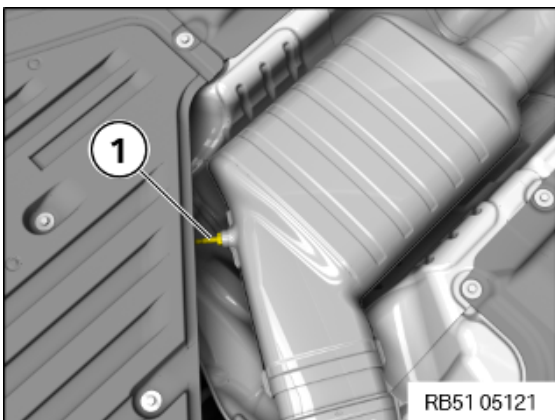

- Tighten the exhaust temperature sensor (1).

#### Exhaust-gas temperature sensor upstream of SCR catalytic converter

Sensor		Tightening torque	30 Nm
--------	--	-------------------	-------



Description is for left component only. Procedure on the right side is identical.

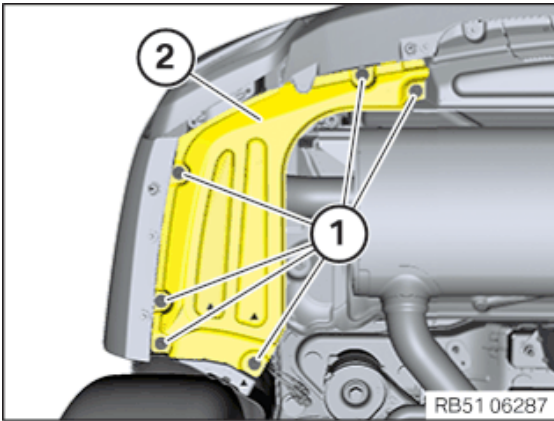

- Guide in rear diffuser (2) and position it correctly.
- Tighten the screws (1).

#### Underbody panelling/frame

Hexagon screw	Tightening torque	3 Nm
---------------	-------------------	------

## 24 – Installing rear right tension strut

### ► Installing the rear tension strut



Driving without the strut brace/front-end strut or tension strut is not permitted.



Description is for left component only. Procedure on the right side is identical.

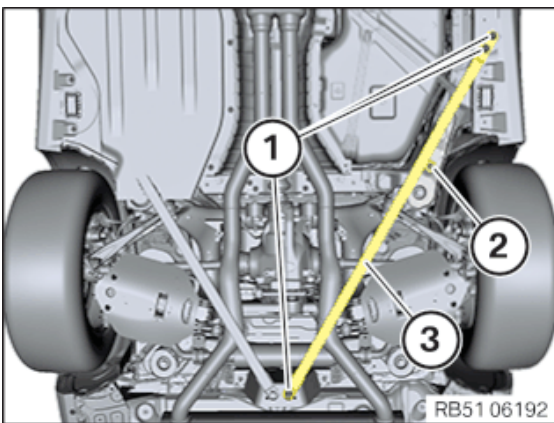

- Install the tension strut (3).
- Tighten the bolts (1) and the nut (2).

#### Torsion strut to body and holder

M12x25	Renew screws.	Jointing torque	100 Nm
		Angle of rotation	90 °
M10 nut		Tightening torque	38 Nm

## 25 – Installing starter motor

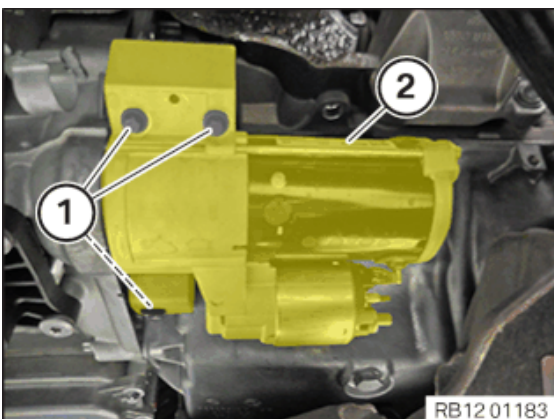

- Insert and install the starter motor (2).
- Tighten the screws (1).

#### Starter motor to crankcase

M8x60	Tightening torque	19 Nm
-------	-------------------	-------

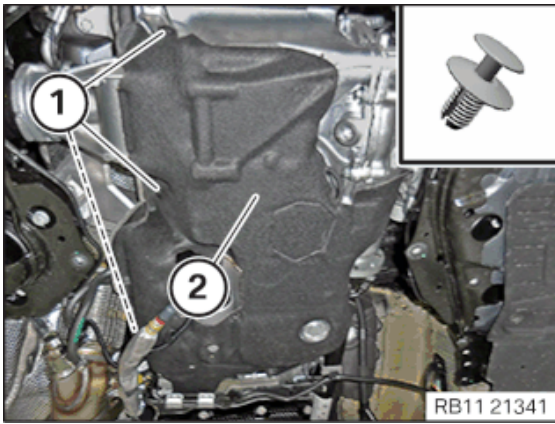

- Position the acoustic cover (2) of the oil sump.
- Mount clips (1).

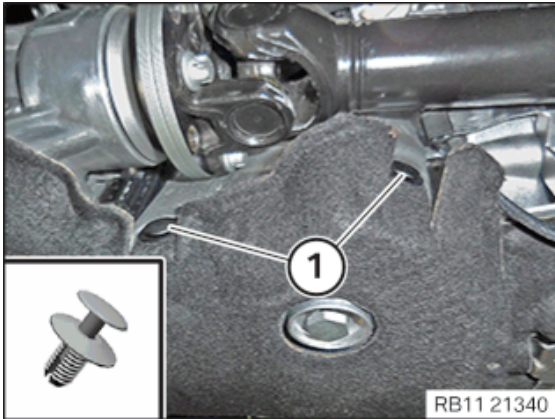

- Mount clips (1).

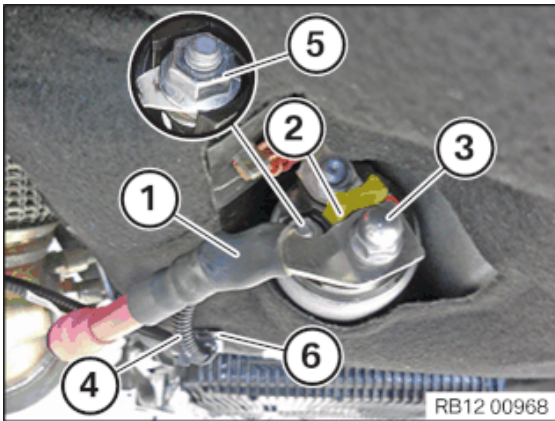

- Insert and install terminal 50 (4).
- Tighten nut (5).

**Terminal 50 to starter motor**

M6	Tightening torque	7,5 Nm
----	-------------------	--------

- Insert and install the positive battery cable (1).
- Attach the positive battery cable (1) to the anti-twist lock (2).
- Tighten nut (3).

**Battery positive lead to starter**

M8	Tightening torque	13,5 Nm
----	-------------------	---------

- Mount the clip (6).

**26 – Installing the acoustic cover for the oil sump**

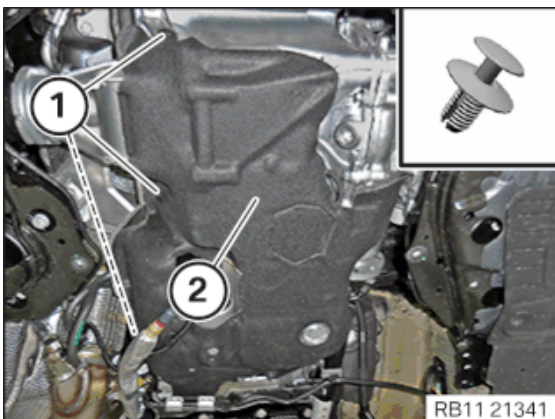

- Position the acoustic cover (2) of the oil sump.
- Mount clips (1).

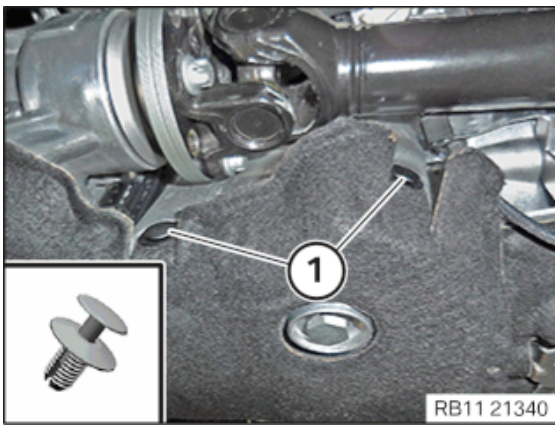

- Mount clips (1).

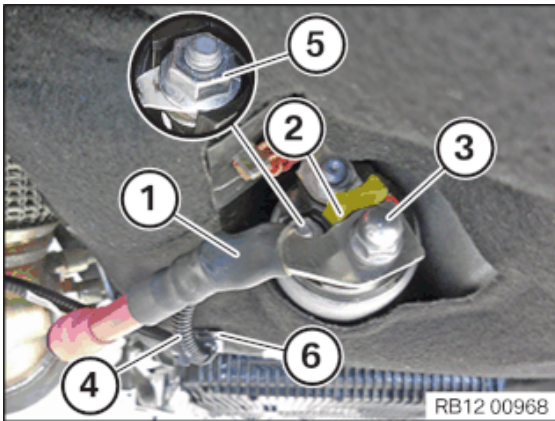

- Insert and install terminal 50 (4).
- Tighten nut (5).

#### Terminal 50 to starter motor

M6	Tightening torque	7,5 Nm
----	-------------------	--------

- Insert and install the positive battery cable (1).
- Attach the positive battery cable (1) to the anti-twist lock (2).
- Tighten nut (3).

#### Battery positive lead to starter

M8	Tightening torque	13,5 Nm
----	-------------------	---------

- Mount the clip (6).

## 27 – Connecting all battery earth leads



- See additional information.

## 28 – Checking/topping up oil level in automatic transmission

### Prerequisite

Vehicle is in a horizontal position.

The vehicle is secured against rolling away.



**Materials harmful to health.**

**Contact with fluids harmful to health!**

- Note and follow safety information on containers.
- Conduct all work in appropriate personal protective equipment only.



To set the correct oil level, it is mandatory that the service function "Transmission control unit: Oil-level adjustment" is carried out with the diagnosis system.



Carry out oil-level adjustment:

Certain fault memory entries may require an oil-level adjustment in the automatic transmission and after repairs have been completed (e.g. exchange of mechatronics, exchange of the converter, exchange of the transmission, automatic transmission oil service).



The automatic transmission fluid specified by BMW must be used for the automatic transmission.

For additional information see: SBS-ANL-SBS1996-240596143\_A14 (automatic transmission fluid for ZF transmissions, etc.)

- Connect diagnosis system.
- Observe the predefined transmission oil temperatures for the oil-level adjustment with the diagnosis system:
  - Initial condition: Transmission oil temperature 30°C to 40°C.
  - Final condition: Transmission oil temperature 40°C to 50°C.
- Call up service function (drive).
- Carry out oil-level adjustment in accordance with the instructions.

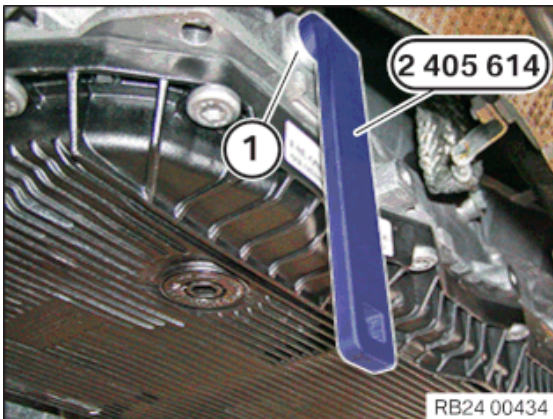

- Loosen the oil filler plug (1) using the special tool **2 405 614**.
- Top up automatic transmission fluid according to the instructions in the diagnosis system.

#### GA8HP51Z transmission capacity

min. 9,28 l

Transmission oil: Automatic transmission fluid ATF 3+

#### GA8HP76Z transmission capacity

min. 9,35 l

Transmission oil: Automatic transmission fluid ATF 3+

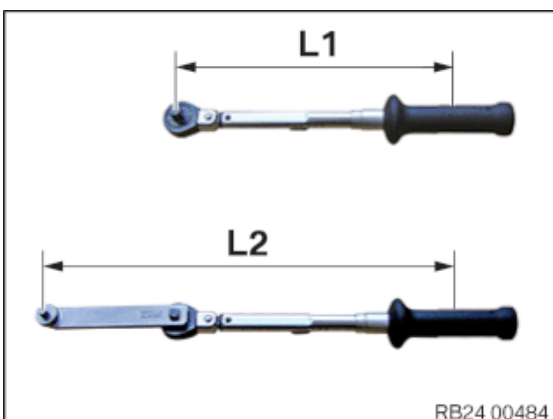

The setpoint torque deviates from the torque to be set when using special tool 2 405 614.

- Converting the setpoint torque into the torque to be set:  
(setpoint torque x L1) : L2 = Torque to be set  
L1 = Length from the centre of the handle to the reversible ratchet head  
L2 = Length from the centre of the handle to the engaging of the special tool in the bolt

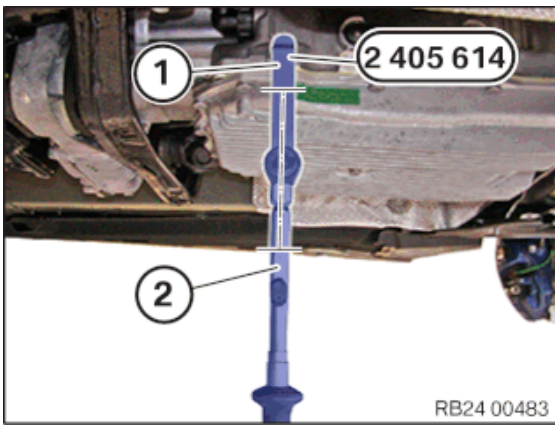

- Renew the oil filler plug (1) and the sealing ring.
- **Parts:** Oil filler plug, sealing ring
- Make sure that the special tool **2 405 614** and the torque wrench (2) align while tightening the oil filler plug (1).
- Tighten the oil filler plug (1) with the special tool **2 405 614** and the torque wrench (2).

#### Oil filler plug

M18x1.5	Tightening torque	35 Nm
---------	-------------------	-------

### 29 – Installing right underbody panelling (tank cover)



Description is for left component only. Procedure on the right side is identical.

#### ► Installing the underbody panelling (tank cover)

- Insert the underbody panelling (1).
- Tighten all bolts and nuts (arrows).

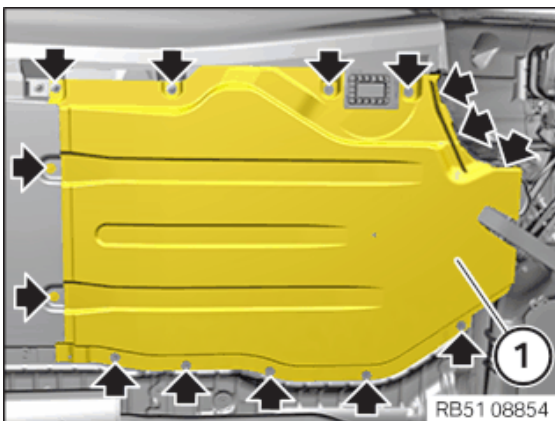

#### Underbody panelling, side

Hexagon screw	Tightening torque	2.6 Nm
Plastic nut	Tightening torque	2.6 Nm

### 30 – Installing underbody protection at rear

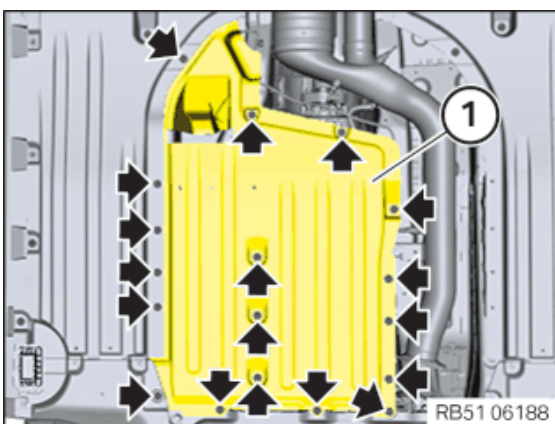

- Guide in underbody protection (1) and position it correctly.
- Tighten screws (arrows).

#### Underbody panelling/frame

Hexagon screw	Tightening torque	3 Nm
---------------	-------------------	------

### 31 – Installing the stiffening plate

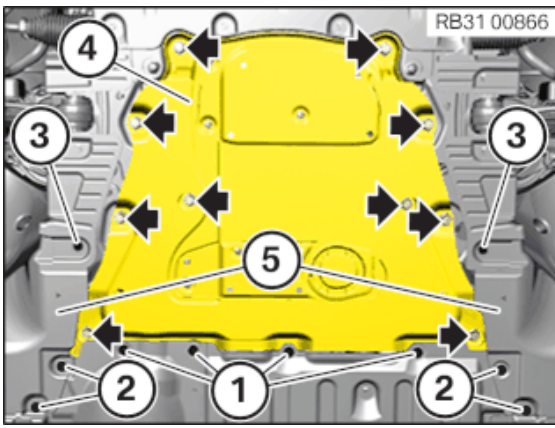

- Guide stiffening plate (4) into area (5) of the wheel arch trim panel and position it on the front axle support.

- Renew the bolts (arrows).

**Parts:** Bolts

- Tighten screws (arrows).

#### Stiffening plate to front axle support

M10	Renew screws.	Jointing torque	56 Nm
		Angle of rotation	90 °

- Tighten down screws (3).

#### Cover, steering unit

Thermoplastic hexagon screw		Tightening torque	2,6 Nm
-----------------------------	--	-------------------	--------

- Tighten down screws (2).

#### Wheel arch cover

Thermoplastic hexagon screw		Tightening torque	2,6 Nm
Plastic nut		Tightening torque	2,6 Nm

- Tighten the screws (1).

#### Underbody panelling/frame

Hexagon screw		Tightening torque	3 Nm
---------------	--	-------------------	------

## 32 – Installing the front underbody protection



Different variants may be installed depending on the vehicle equipment.

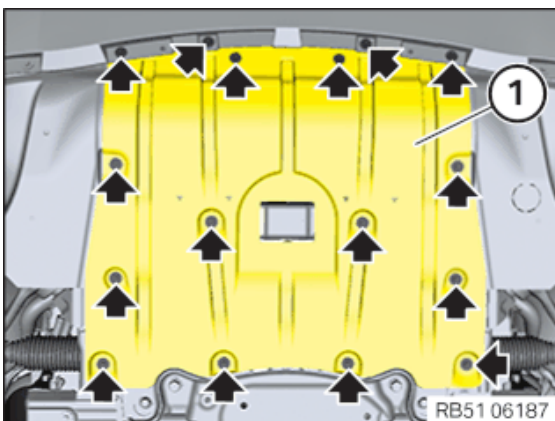

- Insert front underbody protection (1) and position correctly.
- Tighten screws (arrows).

#### Underbody panelling/frame

Hexagon screw		Tightening torque	3 Nm
---------------	--	-------------------	------

### ► Installing the front underride protection



The following work step(s) is / are to be carried out if the specified component(s) is/are fitted.

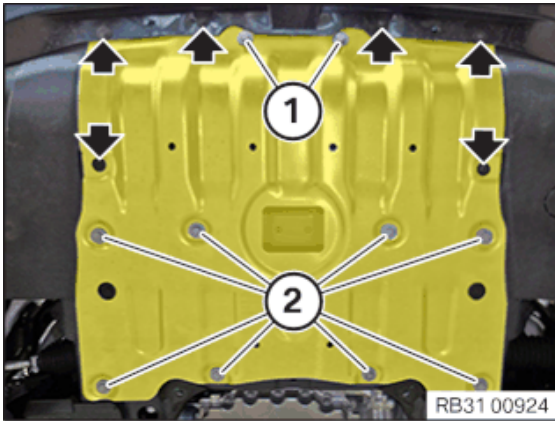

- Insert and position the front underride protection.
- Tighten down screws (2) and (1).

#### Underride protection at the front to the front axle support

M8	Tightening torque	19 Nm
----	-------------------	-------

- Tighten screws (arrows).

#### Underbody panelling/frame

Hexagon screw	Tightening torque	3 Nm
---------------	-------------------	------

### 33 – Install the underbody panelling of the transmission on the side

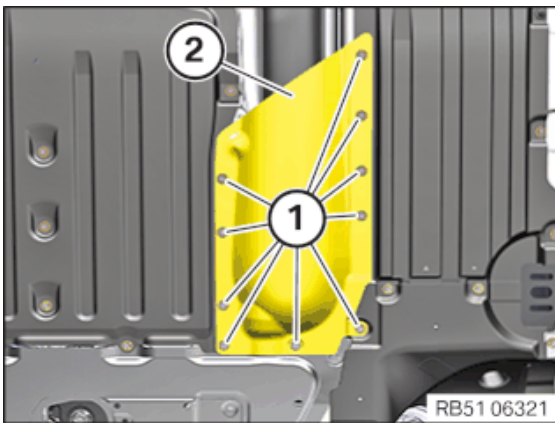

- Install the underbody panelling (2).
- Tighten the screws (1).

#### Underbody panelling, side

Hexagon screw	Tightening torque	2.6 Nm
Plastic nut	Tightening torque	2.6 Nm

## Additional Information

### Overview of Tightening Torques

Torque converter to flywheel			Used in step <a href="#">17</a>
M10	Renew screws.	Tightening torque	56 Nm
Transmission to engine			Used in step <a href="#">17</a>
M8		Tightening torque	19 Nm
M12		Tightening torque	66 Nm
Transmission oil line to transmission			Used in step <a href="#">17</a>
M6x25	Renew the sealing ring.	Tightening torque	8 Nm
Transfer box to automatic transmission			Used in step <a href="#">17</a>
M10		Tightening torque	43 Nm
Propeller shaft before the front axle differential			Used in step <a href="#">17</a>
Renew screws.		Tightening torque	20 Nm
Jointing torque and angle of rotation must be observed without fail.		Angle of rotation	45 °

<b>Ground strap to transmission or body</b>			Used in step <a href="#">17</a>
M8		Tightening torque	19 Nm
<b>Transmission bearing support to body</b>			Used in step <a href="#">17</a>
M8		Tightening torque	19 Nm
<b>Transmission cross member to body</b>			Used in step <a href="#">17</a>
M8		Tightening torque	19 Nm
<b>Transmission cross member to rubber mounts</b>			Used in step <a href="#">17</a>
M12		Tightening torque	68 Nm
<b>Front flexible disc to propeller shaft</b>			Used in step <a href="#">18</a>
M12	Renew screws. Comply with jointing torque and angle of rotation. Tightening via screw.	Jointing torque	55 Nm
		Angle of rotation	90 °
<b>Centre mount to body</b>			Used in step <a href="#">18</a>
M8		Tightening torque	19 Nm
<b>Retaining plates for vehicle underbody cover</b>			Used in step <a href="#">19</a>
Sheet metal nut/plastic nut	Renew nuts.	Tightening torque	3 Nm
<b>Connecting support on tunnel to body</b>			Used in step <a href="#">20</a>
Hexagon screw M10x25	Replace screws	Tightening torque	56 Nm
		Angle of rotation	90 °
<b>Heat shield to undercarriage</b>			Used in step <a href="#">21</a>
Screws and nuts		Tightening torque	3 Nm
<b>Rear silencer to body / bumper support</b>			Used in step <a href="#">22</a>
M8	Replace nuts.	Tightening torque	19 Nm
<b>Exhaust system to rear axle carrier</b>			Used in step <a href="#">22</a>
M8x25	Renew screw.	Tightening torque	28 Nm
<b>Exhaust system to diesel particle filter</b>			Used in step <a href="#">22</a>
M8	Renew gasket.	Tightening torque	19 Nm
<b>Nitrogen oxide sensor downstream of SCR catalytic converter</b>			Used in step <a href="#">22</a>
Sensor		Tightening torque	55 Nm
<b>Diesel particulate sensor to exhaust system</b>			Used in step <a href="#">22</a>
Sensor		Tightening torque	50 Nm
<b>Protective plate for SCR exhaust gas sensor system</b>			Used in step <a href="#">22</a>
Hexagon screw		Tightening torque	2,6 Nm

<b>Exhaust-gas temperature sensor upstream of SCR catalytic converter</b>			Used in step <a href="#">22</a>
Sensor		Tightening torque	30 Nm
<b>Underbody panelling/frame</b>			Used in step <a href="#">23</a> <a href="#">30</a> <a href="#">31</a> <a href="#">32</a>
Hexagon screw		Tightening torque	3 Nm
<b>Torsion strut to body and holder</b>			Used in step <a href="#">24</a>
M12x25	Renew screws.	Jointing torque	100 Nm
		Angle of rotation	90 °
M10 nut		Tightening torque	38 Nm
<b>Starter motor to crankcase</b>			Used in step <a href="#">25</a>
M8x60		Tightening torque	19 Nm
<b>Terminal 50 to starter motor</b>			Used in step <a href="#">25</a> <a href="#">26</a>
M6		Tightening torque	7,5 Nm
<b>Battery positive lead to starter</b>			Used in step <a href="#">25</a> <a href="#">26</a>
M8		Tightening torque	13,5 Nm
<b>Oil filler plug</b>			Used in step <a href="#">28</a>
M18x1.5		Tightening torque	35 Nm
<b>Underbody panelling, side</b>			Used in step <a href="#">29</a> <a href="#">33</a>
Hexagon screw		Tightening torque	2.6 Nm
Plastic nut		Tightening torque	2.6 Nm
<b>Stiffening plate to front axle support</b>			Used in step <a href="#">31</a>
M10	Renew screws.	Jointing torque	56 Nm
		Angle of rotation	90 °
<b>Cover, steering unit</b>			Used in step <a href="#">31</a>
Thermoplastic hexagon screw		Tightening torque	2,6 Nm
<b>Wheel arch cover</b>			Used in step <a href="#">31</a>
Thermoplastic hexagon screw		Tightening torque	2,6 Nm
Plastic nut		Tightening torque	2,6 Nm
<b>Underride protection at the front to the front axle support</b>			Used in step <a href="#">32</a>
M8		Tightening torque	19 Nm

## Overview of Special Tools

### 0 495 498 (23 4 050) Fixture

<b>Common</b>		Used in step <a href="#">16</a>
Usage	(universal gearbox holder) Support for removing and installing manual gearboxes and	

automatic transmissions for BMW & RR.

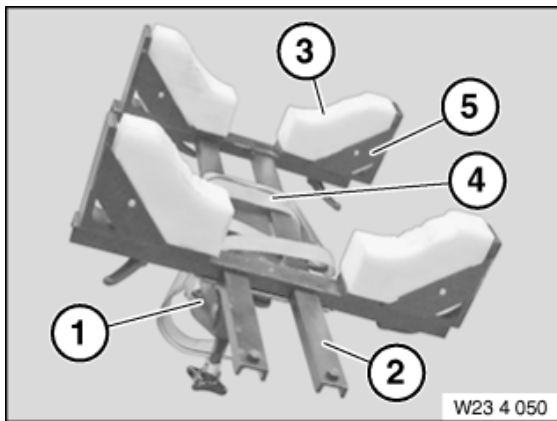

Included in the tool or work  
 Storage location Individual  
 Replaced by  
 In connection with  
 SI-Number 01 07 06 (256)

**Consisting of**

Pos	BMW Order number	Replaced by	Designation	In Connection with
3	<a href="#">0 495 549 (23 4 053)</a>		<b>Insert</b> (foam inserts (1 set = 4 pcs.))	
1	<a href="#">0 495 547 (23 4 051)</a>		<b>Joint</b> Available only as a complete tool set 23 4 050 (83 30 0 495 498) - as of 16.07.12.	
2	<a href="#">0 495 548 (23 4 052)</a>		<b>Frame</b> (Basic frame) Available only as a complete tool set 23 4 050 (83 30 0 495 498) - as of 16.07.12.	
4	<a href="#">0 495 550 (23 4 054)</a>		<b>Belt</b> (Tensioning strap) Available only as a complete tool set 23 4 050 (83 30 0 495 498) - as of 16.07.12.	
5	<a href="#">0 496 018 (23 4 055)</a>		<b>Fixture</b> (Fixture for foam insert) Available only as a complete tool set 23 4 050 (83 30 0 495 498) - as of 16.07.12.	

**2 219 012 Hydraulic lifter**



**Common** Used in step 16

Usage For raising and lowering various vehicle components.  
 Included in the tool or work  
 Storage location  
 Replaced by  
 In connection with  
 SI-Number 01 05 90 (207)

**0 493 380 (11 6 480) Connector**

**Common** Used in step 16 17

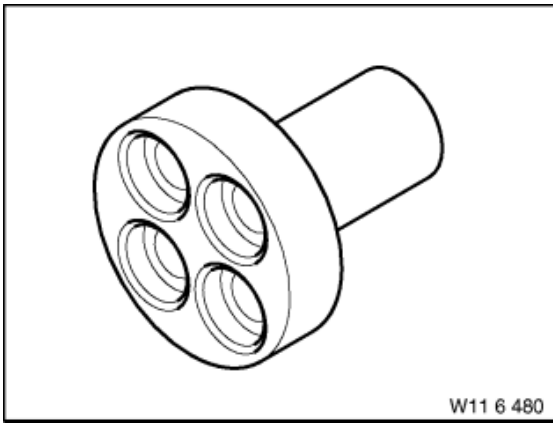

Usage For turning over engine at crankshaft hub (vibration absorber).

Included in the tool or work

Storage location

Replaced by

In connection with

SI-Number 01 11 98 (338)

### 0 494 478 (24 4 161) Basic body

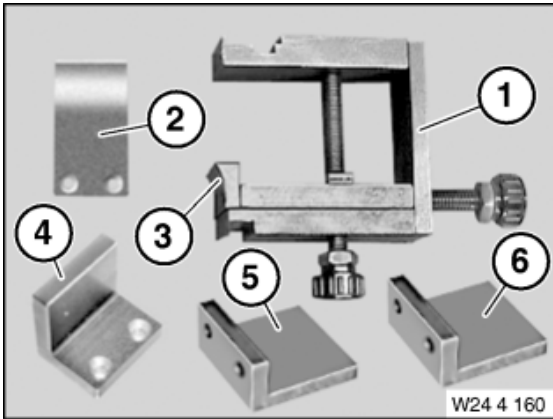

#### Common

Used in step 16

Usage

Included in the tool or work 0 494 451

Storage location B45

Replaced by

In connection with

SI-Number

### 0 494 622 (24 4 164) Shaped element

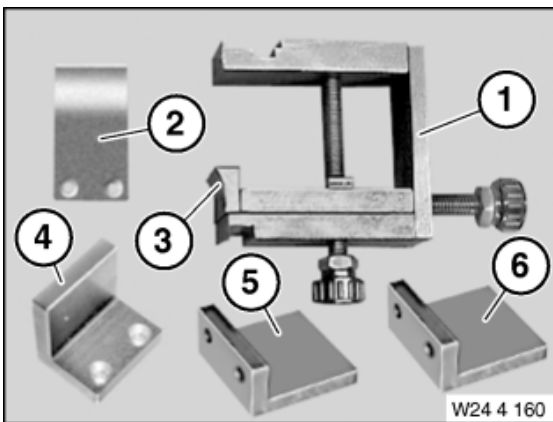

#### Common

Used in step 16

Usage

For converter version M54 discontinued, available as part of set of special tools only

Included in the tool or work 0 494 451

Storage location B45

Replaced by

In connection with

SI-Number

### 0 494 451 (24 4 160) Holder

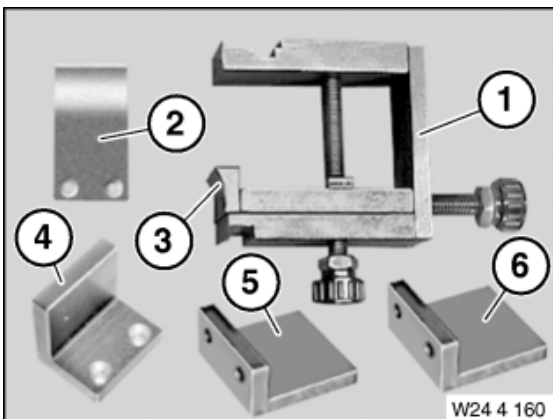

#### Common

Used in step 16 17

Usage

For securing converter during removal and installation of transmission

Included in the tool or work

Storage location B45

Replaced by

In connection with

SI-Number 01 11 02 (908)

#### Consisting of

Pos	BMW Order number	Replaced by	Designation	In Connection with
2	<a href="#">0 494 479 (24 4 162)</a>		<b>Shaped element</b> For converter version N73 discontinued, available as part of set of special tools only	
5	<a href="#">0 494 965 (24 4 165)</a>		<b>Shaped element</b> Transmission: GA6 HP19 in E87, E90 Discontinued, available as part of set of special tools only	
3	<a href="#">0 494 477 (24 4 163)</a>		<b>Shaped element</b> For converter version M57TU discontinued, available as part of set of special tools only	
1	<a href="#">0 494 478 (24 4 161)</a>		<b>Basic body</b>	
4	<a href="#">0 494 622 (24 4 164)</a>		<b>Shaped element</b> For converter version M54 discontinued, available as part of set of special tools only	
6	<a href="#">0 496 061 (24 4 166)</a>		<b>Shaped element</b> Transmission: GA6L45R (GM6) in E83 / N52K Discontinued, available as part of set of special tools only	

### 0 494 213 (24 2 390) Cap



Common		Used in step
Usage	(protective cap) For sealing off the guide sleeve of the transmission connector	16 17
Included in the tool or work		
Storage location	C49	
Replaced by		
In connection with		
SI-Number	01 14 01 (766)	

### 0 490 189 (00 2 550) Measurement aid

Common		Used in step
Usage	(Depth gauge) E.g. for determining side clearance of transmission shaft and basic adjustment dimension for installing bevel pinion in rear axle final drives	17
Included in the tool or work		

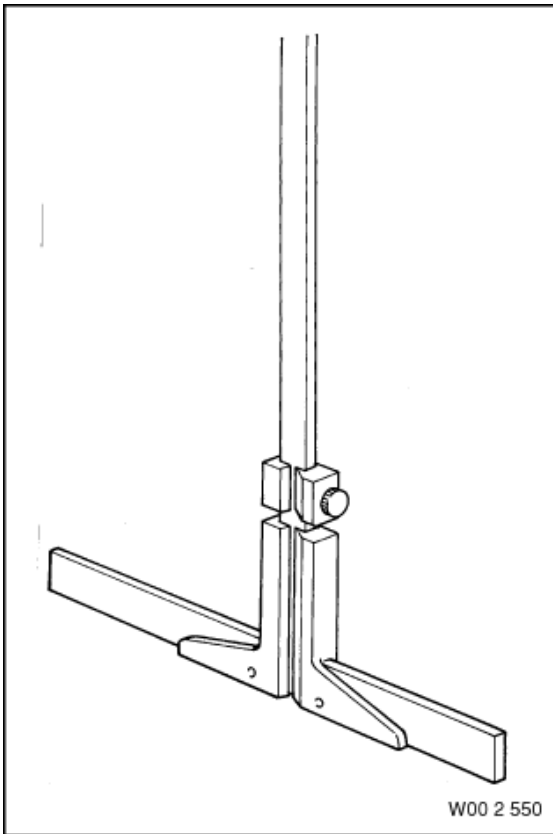

Storage location A4

Replaced by

In connection with

SI-Number

**0 491 667 (24 1 110) Socket wrench insert**

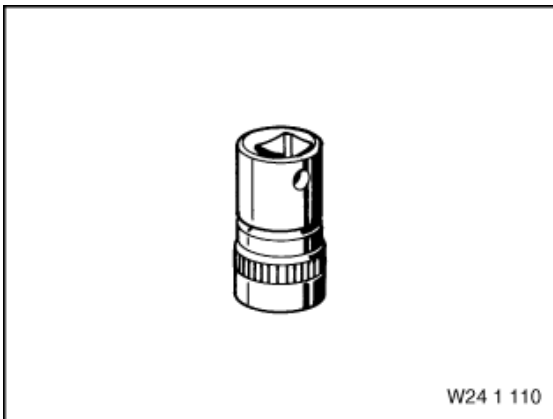

**Common**

Used in step [17](#)

Usage

Loosening and fastening the converter fastener

Included in the tool or work

Storage location A14

Replaced by

In connection with

SI-Number 01 04 86 (566)

**0 490 504 (00 9 120) Torque angle measuring dial**



**Common**

Used in step [18](#)

Usage

For torsion angle adjustment of cylinder head bolts (all engines) And reinforcement plate front axle support E46

Included in the tool or work

Storage location A4

Replaced by

In connection with

SI-Number

**2 405 614 Socket wrench**

**Common**

Used in step [28](#)

Usage

For opening and closing the oil filler plug.



Contour-graphic silhouette foil is included in delivery specification. Further information on the contour-graphic silhouette foil can be found in service information 00 22 13 (969). Replaced by 2455997

Included in the tool or work

Storage location

Replaced by

In connection with

SI-Number 01 33 15 (305)

## Overview Technical Data

### **GA8HP51Z transmission capacity**

Used in step [28](#)

min. 9,28 l

Transmission oil: Automatic transmission fluid ATF 3+

### **GA8HP76Z transmission capacity**

Used in step [28](#)

min. 9,35 l

Transmission oil: Automatic transmission fluid ATF 3+